

SERVICE MANUAL

ED PRIMA



Victoria Arduino

INSPIRED BY YOUR PASSION.

MACHINE DESCRIPTION	01
FIRST INSTALLATION AND PRELIMINARY OPERATIONS	02
REMOVAL OF THE EXTERNAL SURFACE	03
INFUSION GROUP	04
STEAM BOILER	05
COFFEE BOILERS	06
HYDRAULIC CIRCUIT	07
ELECTRIC COMPONENTS	08
PROGRAMMING	09
ALARMS AND CONTROL OF THE EMERGENCIES	10
MAINTENANCE CHECK LIST	11
TROUBLESHOOTING	12
DIAGRAMS	13
SPARE PARTS BOOK	14



GENERAL INDEX

01	MACHINE DESCRIPTION	9
1.1	MACHINE GENERAL DESCRIPTION	10
1.2	SAFETY REGULATIONS	11
1.3	PREPARATION BY THE PURCHASER	15
1.4	SYMBOLS	16
1.5	RESIDUAL RISKS	16
1.6	MACHINE RECEIVING	16
1.6.1	TRANSPORT	16
1.6.2	MOVEMENTS	17
1.6.3	STORAGE	17
1.6.4	UNPACKING	17
1.7	CONTENTS CHECK	18
02	FIRST INSTALLATION AND PRELIMINARY OPERATIONS	19
2.1	POSITIONING	20
2.2	TECHNICAL CHARACTERISTIC	21
2.3	WATER SPECIFICATIONS	22
2.4	ELECTRICAL SPECIFICATIONS	22
2.5	WATER SUPPLY	23
2.5.1	TANK VERSION	23
2.5.2	DIRECT CONNECTION VERSION	24
2.5.3	SOFTWARE SWITCH FROM TANK TO DIRECT CONNECTION VERSION AND VICE-VERSA	25
2.5.4	DIRECT WASTE WATER SYSTEM	26
2.6	PROCEDURE OF FIRST POWERING ON	27
2.7	WATER INPUT PRESSURE FOR DIRECT CONNECTION VERSION	29
2.8	ADJUSTMENT OF THE PRESSURE	29
2.9	HOT WATER ECONOMISER ADJUSTMENT	30
2.10	BASIC PROGRAMMING	30
03	REMOVAL OF EXTERNAL SURFACE	31
3.1	REMOVAL OF THE CUP HOLDER SURFACE	33
3.2	REMOVAL OF THE SIDE PANELS	34
3.3	REMOVAL OF THE REAR PANEL	35
3.3.1	DISASSEMBLE THE REAR PANEL	37
3.4	REMOVAL OF LOWER REAR PANEL	38
3.5	REMOVAL OF THE LOWER FRONT PANEL	39
3.6	REMOVAL OF THE GROUP COVER	41
04	INFUSION GROUP	43
4.1	REMOVAL OF SHOWER, PAVILION AND SEAL	46
4.2	FILTER HOLDER PRESENCE SENSOR	46
4.2.1	REMOVAL OF THE FILTER HOLDER PRESENCE SENSOR	47
4.3	REPLACING THE SEAL IN THE PRE-INFUSION CHAMBER	49
4.4	HEATING ELEMENT	50
4.4.1	REMOVAL OF THE HEATING ELEMENT	51
4.5	TEMPERATURE PROBE	53
4.5.1	REMOVAL OF THE TEMPERATURE PROBE	54
4.6	HIGH-LIMIT THERMOSTATS	55
4.7	COFFEE VALVE	56
4.7.1	REDUCING OF THE COFFEE BOILER INNER PRESSURE	56
4.7.2	REMOVAL OF THE COFFEE VALVE	56



05	STEAM BOILER	59
5.1	REDUCING STEAM BOILER PRESSURE	61
5.2	EMPTYING THE STEAM BOILER	61
5.3	ACCESS TO HEATING ELEMENT	62
5.4	REMOVAL OF THE STEAM BOILER	66
5.4.1	TEST THE HEATING ELEMENT	66
5.4.2	REMOVE THE HEATING ELEMENT	67
5.5	THE SAFETY THERMO-FUSE	68
5.6	THE LEVEL PROBE	70
5.7	ANTI-SUCTION VALVE	71
5.8	SAFETY VALVE	72
06	COFFEE BOILERS	73
6.1	REMOVAL OF THE COFFEE BOILER	75
6.2	HEATING ELEMENT	79
6.2.1	CHECK AND REMOVAL OF THE HEATING ELEMENT	79
6.3	TEMPERATURE PROBE	81
6.3.1	REMOVAL OF THE TEMPERATURE PROBE	82
6.4	HIGH-LIMIT THERMOSTATS	84
6.5	EXPANSION VALVE	84
6.5.1	REMOVAL OF THE EXPANSION VALVE	84
6.6	PROCEDURE FOR AUTOMATICALLY FILLING THE COFFEE BOILER	86
07	HYDRAULIC CIRCUIT	87
7.1	EXHAUST MANIFOLD AND DRAIN BOX	88
7.2	TANK	89
7.3	TANK VALVE AND WATER STOP VALVE	89
7.3.1	REMOVAL OF THE TANK VALVE	89
7.3.2	REMOVAL OF THE WATER STOP VALVE	91
7.4	THE PUMPING ELEMENT	93
7.4.1	REMOVAL OF THE PUMP	93
7.4.2	REMOVAL OF THE CONDENSER	97
7.4.3	REMOVAL OF THE MOTOR	97
7.5	REMOVAL OF THE AUTO-FILL VALVE	98
7.6	FLOWMETER AND NOT RETURN VALVE	100
7.6.1	REMOVAL OF THE FLOWMETER	101
7.6.2	REMOVAL OF THE PRE INFUSION RESTRICTOR	104
7.6.3	REMOVAL OF THE NOT-RETURN VALVE	104
7.7	HOT AND COLD WATER VALVE	105
7.7.1	REMOVAL OF THE HOT WATER VALVE	106
7.7.2	REMOVAL OF THE COLD WATER VALVE	109
7.8	STEAM VALVE	110
7.8.1	REMOVAL OF THE STEAM VALVE	110
7.9	STEAM, HOT WATER AND EASYCREAM (OPTIONAL) WANDS .	114
7.9.1	DISMANTLING THE WAND	114
7.10	EASYCREAM (OPTIONAL)	118
7.11	REMOVAL OF THE PRESSURE GAUGE	121



08	ELECTRIC COMPONENTS	123
8.1	CONTROL UNIT	124
8.1.1	CONTROL UNIT LEDS	128
8.2	CONTACTOR	129
8.3	STATIC RELAY	130
8.4	TRANSFORMER	131
8.5	PRESSURE TRANSDUCERS	133
8.5.1	REMOVAL OF THE WATER PRESSURE TRANSDUCER	133
8.5.2	REMOVAL OF THE STEAM BOILER PRESSURE TRANSDUCER	134
8.6	GROUP COVER AND SERVICE BOARD	135
8.7	SERVICE KNOB	137
8.8	WATER TANK PRESENCE SENSOR	138
8.9	LIGHTS	139
09	PROGRAMMING	141
9.1	BASIC FUNCTIONS	142
9.1.1	MACHINE ON/OFF	142
9.1.2	STAND-BY	142
9.1.3	SWITCHING FROM TANK TO DIRECT CONNECTION	143
9.1.4	SWITCHING FROM DIRECT CONNECTION TO TANK	143
9.2	PROGRAMMING	144
9.2.1	COFFEE TEMPERATURE	145
9.2.2	COFFEE DOSES	146
9.2.3	HOT WATER DOSES	148
9.2.4	EASYCREAM TEMPERATURE (OPTIONAL)	150
9.3	CLEANING PROCEDURE	151
9.4	SPECIAL FUNCTIONS	155
9.4.1	GHOST DISPLAY VERIFICATION PROCEDURE	155
9.4.2	EMPTY BOILER PROCEDURE	155
9.4.3	FILLING PROCEDURE	156
9.4.4	RESET COUNTERS PROCEDURE	157
9.4.5	RESET PARAMETERS PROCEDURE	158
9.5	MACHINE UPDATE	160
10	ALARMS AND CONTROL OF THE EMERGENCIES	163
10.1	ALARMS AND SOLUTIONS	164
11	MAINTENANCE CHECK LIST	169
11.1	SIX (6) MONTHS OR 50000 CYCLES MAINTENANCE	170
11.2	TWELVE (12) MONTHS OR 100000 CYCLES MAINTENANCE	171
11.3	ONE (1) YEAR MAINTENANCE KIT	172
12	TROUBLESHOOTING	173
12.1	COFFEE DOSAGE ERROR	174
12.2	BOILER FILLING TIME OUT	175
12.3	HEATING TIMEOUT	176
12.3.1	STEAM BOILER HEATING ERROR	176
12.3.2	COFFEE BOILER HEATING ERROR	177
12.3.3	COFFEE GROUP HEATING ERROR	178



13	DIAGRAMS	179
13.1	HYDRAULIC SCHEME	180
13.2	230V ELECTRICAL DIAGRAM	182
13.3	110V ELECTRICAL DIAGRAM	184
13.4	BOILER DIAGRAM	186
14	SPARE PARTS BOOK	187
14.1	CABINET PARTS	188
14.2	CONTROL PANEL PARTS	190
14.3	POURING GROUP PARTS	192
14.4	HYDRAULIC PARTS	194
14.5	STEAM & HOT WATER PARTS	196
14.6	EASYCREAM PARTS	198
14.7	HYDRAULIC GROUP PARTS	200
14.8	BOILER PARTS	202
14.9	FRAME PARTS	204
14.10	ELECTRONIC & ELECTRICAL PARTS	206





INDEX

01	MACHINE DESCRIPTION	9
1.1	MACHINE GENERAL DESCRIPTION	10
1.2	SAFETY REGULATIONS	11
1.3	PREPARATION BY THE PURCHASER	15
1.4	SYMBOLS	16
1.5	RESIDUAL RISKS	16
1.6	MACHINE RECEIVING	16
1.6.1	TRANSPORT	16
1.6.2	MOVEMENTS	17
1.6.3	STORAGE	17
1.6.4	UNPACKING	17
1.7	CONTENTS CHECK	18

1.1 MACHINE GENERAL DESCRIPTION

01

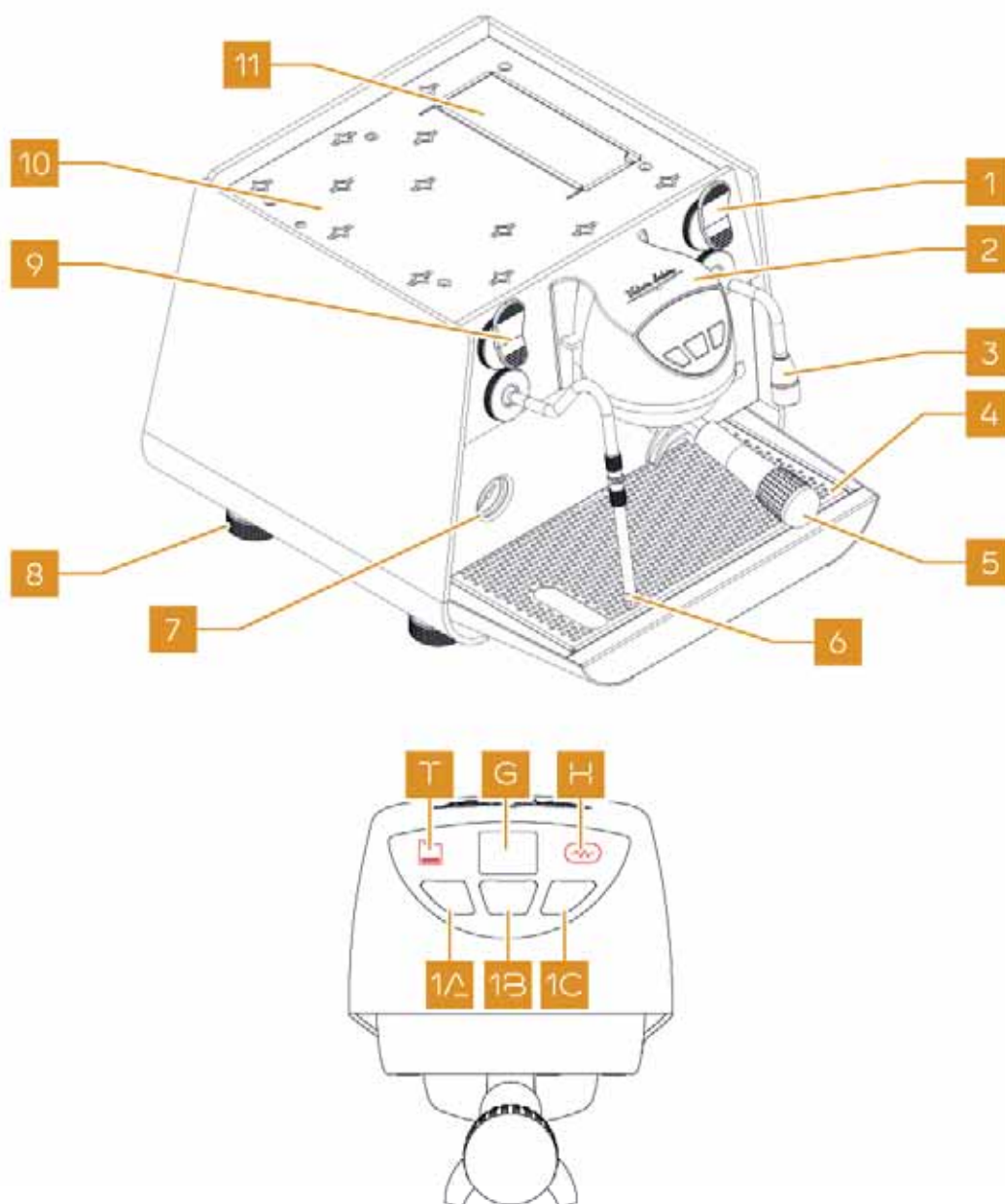

- 1 Hot water knob
- 2 Infusion group
- 3 Hot water wand
- 4 Drip tray
- 5 Filter-holder
- 6 Steam wand
- 7 Pressure gauge
- 8 Machine foot
- 9 Steam knob
- 10 Cup holder surface
- 11 Tank

- 1A Coffee delivery button dose 1
- 1B Continuous coffee delivery button
- 1C Coffee delivery button dose 2

- T Tank icon
- G Ghost display
- H Heating icon

1.2 SAFETY REGULATIONS

Read this book carefully. It provides important information concerning safety of installation, use and maintenance. Save it carefully for future reference.

All illustrations contained in this manual are meant for information purposes only.

Your machine may differ slightly from the one shown here.

Simonelli Group reserves the right to make changes to production and to the manual without any obligation to update previous production and manuals accordingly.

After unpacking, make sure the appliance is complete. In case of doubts, do not use the appliance, but contact a qualified technician. Packaging items which are potentially dangerous (plastic bags, polystyrene foam, nails, etc.) must be kept out of children's reach and must not be disposed of in the environment.

RISK OF POLLUTION

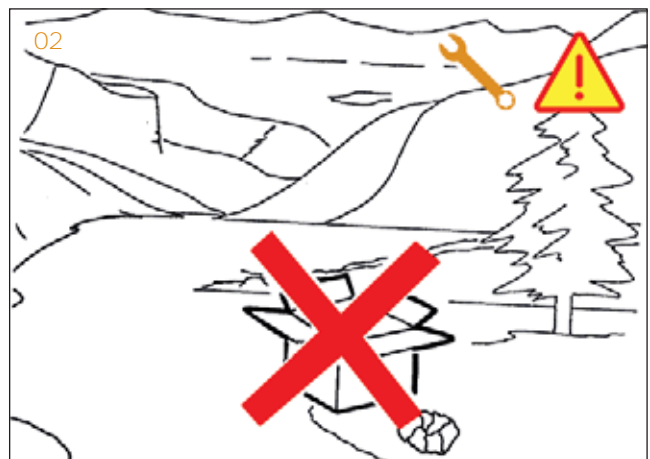

This machine could be installed in locations where its use and maintenance is done by trained personnel or in household and similar applications such as:

- staff kitchen areas in shops, offices and other working environments;
- farm houses;
- by clients in hotels, motels and other residential type environments;
- bed and breakfast type environments.

Before turning ON the machine make certain that the rating indicated on the label matches the available power supply. The nameplate can be seen inside the machine when removing the drip tray.

The machine must be installed according to the applicable federal, state and local standards (codes) in force with regard to plumbing systems including back-flow prevention devices. For this reason, the plumbing connections must be carried out by a qualified technician. The warranty expires if the characteristics of the power supply do not correspond to the nameplate data.

The appliance must be installed according to the applicable federal/national/local standards (codes) concerning the hydraulic systems including back-flow devices. Owing to the above, the hydraulic connections must be carried out by a skilled technician. The warranty will be rendered null and void in case the features of the power supply do not match the plate data.

In case of installation in kitchens, connect the equipotential conductor to the terminal on the machine indicated by the symbol .

The manufacturer is not held responsible for possible damage caused by failure in earthing the plant. For the electrical safety of the appliance, it is necessary to equip the system with the proper grounding. This must be carried out by a qualified electrician who must ensure that the electric power of the system is sufficient to absorb the maximum power input stated on the plate.



The electrician with the appropriate qualification certificate must make sure that the section of the system cables is suitable to the power absorbed by the machine.

The use of adapters, multiple sockets or extensions is strictly forbidden. If they prove necessary, call a fully qualified electrician.

When installing the device, it is necessary to use the parts and materials supplied with the device itself.

Should it be necessary to use other parts, the installation engineer needs to check their suitability for use in contact with water for human consumption.

The machine must be installed in compliance with the local health standards in force for Hygiene and water safety environmental protection. Therefore, contact an authorized service man.

For connecting the waterline, always use a new pipe supplied, Do not use old pipes.

The device needs to be supplied with water that is suitable for human consumption and compliant with the regulations in force in the place of installation. The installation engineer needs confirmation from the owner/manager of the system that the water complies with the requirements and standards stated above.

This appliance must only be used as described in this handbook. The manufacturer shall not be liable for any damage caused due to improper, incorrect and unreasonable use.

This appliance is not suitable for use by children or persons with reduced physical, sensory or mental capabilities, or by persons with a lack of experience or knowledge, unless supervised or given instructions.

Children shall not play with the appliance. Cleaning and user maintenance shall not be made by children without supervision.

The appliance shall not be installed where water jets can be used.

The operating temperature must be within the range of $[+5, +25]^{\circ}\text{C}$.

At the end of installation, the device is switched ON and taken to rated operating conditions, leaving it in a state in which it is "ready for operation".

After reaching the "ready for operation" condition, the following dispensing operations are carried out:

- 100% of the coffee circuit through the coffee dispenser (for more than one dispenser, this is divided equally);
- Opening of the steam outlet for 1 minute.

At the end of installation, it is good practice to draw up a report of the operations.

Basic rules must be observed when using any electric appliance. Never:

- Touch the machine with wet hands or feet;



RISK OF SHORT CIRCUITS

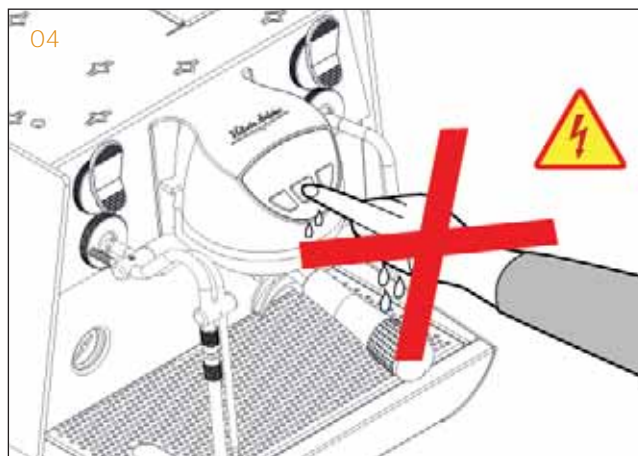

- Use the machine barefoot;
- Use extensions in places used as bath or shower;
- Pull the supply cable to disconnect the machine from the power mains;
- Leave the machine exposed to atmospheric agents (rain, sun, etc.);
- Allow the machine to be used by children or by non-authorized personnel that haven't read and understood this manual.

It is forbidden to leave the machine switched ON without the presence and surveillance of a qualified operator.

Simonelli Group is not responsible for damages caused by failure to comply with this prohibition.

During installation, the mains power system needs to be equipped with a disconnect switch to cut-off each phase.

In case of fire, disconnect power to the machine by turning OFF the main switch. Its absolutely avoid to extinguish the fire with water while power to the machine is ON.

Should it be necessary to replace the power cord, this replacement operation must only be performed by an authorized service centre or by the manufacturer.

Before servicing the appliance, the authorised technician must switch OFF the appliance and unplug it first.

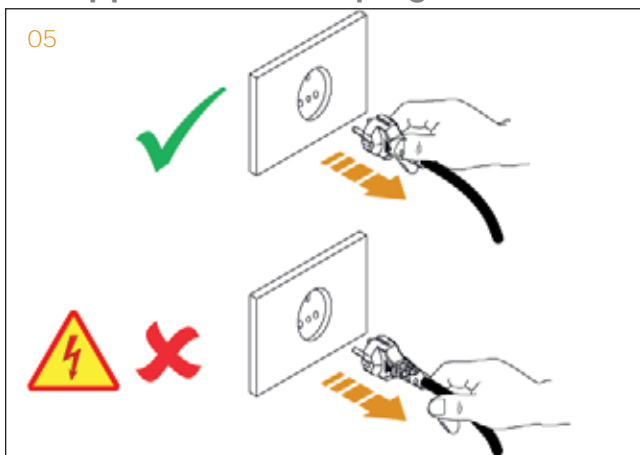

For all cleaning operations, comply exclusively with the instructions given in this booklet manual.

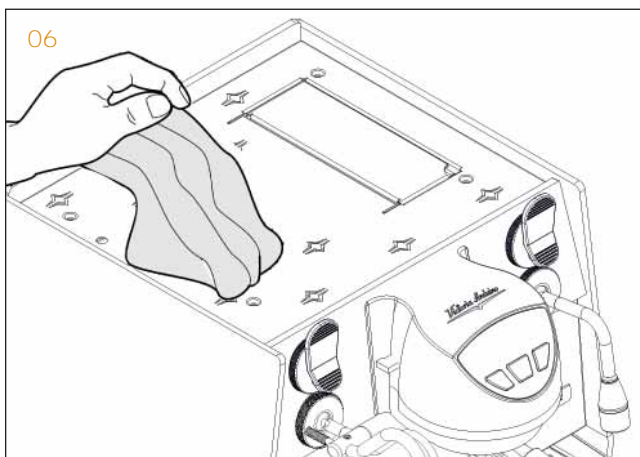

In case of breakdown or wrong functioning of the machine, switch it OFF. Any intervention is strictly forbidden. Contact qualified experts only.

Repairs should only be made by the manufacturer or authorized service centres. Use only original spare parts.

Non-compliance with the above stated can compromise the safety of the machine.

During installation, the licensed electrician shall provide an omni-polar switch as per the applicable safety standard with opening distance of the contacts, which allows the complete disconnection in the conditions in the overvoltage category III. For Australia, the above must be done according to the AS/NZS 3000 installation standard.

To avoid dangerous overheating, make sure the supply cord is fully uncoiled.

Do not obstruct the extraction and/or dissipator grids, especially of the cup holder surface.

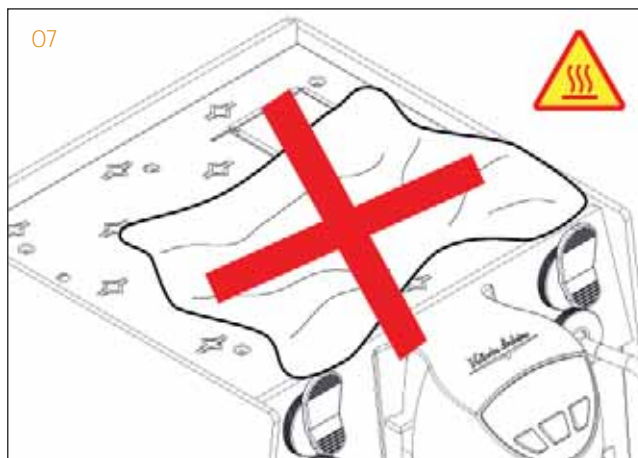

To support the aeration of the machine, place it with a distance of 100 mm from the walls or from other machines on the aeration side.





**CAUTION
RISK OF POLLUTION**

Do not dispose of the machine in the environment; for the disposal, contact an authorized service centre or contact the manufacturer for indications.



Should you decide to stop using the machine, we suggest you render it inoperable by unplugging it and cutting the power supply cord.



**WARNING
RISK OF BURNS OR SCALDING**

Use the steam wand with care and never place hands below the jet of steam. Steam can cause burns when directed towards the body.

Do not touch the wand immediately after use.

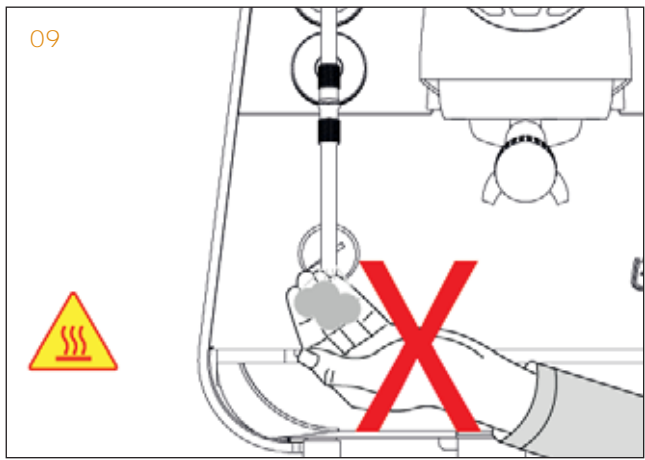

**WARNING
RISK OF BURNS OR SCALDING**

We remind you that before carrying out any installation, maintenance, unloading or adjustment operations, the qualified operator must put on work gloves and protective footwear.

Immediately after turning OFF the machine, and after use, the surface of the coffee brew unit and other areas of the machine remain hot.

When the machine is left unattended for a long period, close the water inlet cap.



RISK OF POLLUTION

After washing is started, do not stop it to prevent detergent residues from remaining into the delivery group.

The maximum noise disturbance level is lower than 70 db.

If the pipe connecting to the mains water is replaced the old pipe must never be re-used.

In case of machine with water connection to the line, the minimum pressure must be 2 bar and the max. pressure for the proper operation of the machine must not exceed 4 bar.

CLEANING CAUTIONS

Some operations must be carried out when the machine is switched OFF, while others can be carried out when the machine is switched ON.

Follow the procedures described and take particular care when carrying out any cleaning operations.

To prevent damage to the appliance do not use alkaline cleaning agents when cleaning, use a soft cloth and a mild detergent (AS/NZS 60335.2.15:2019).





WARNING

INFORMATION TO THE USERS



Under the senses of the Directive 2015/863/EU, concerning the reduction of the use of dangerous substances in electric and electronic equipment, as well as the disposal of wastes.

The symbol of the crossed large rubbish container that is present on the machine points out that the product at the end of its life cycle must be collected separately from the other wastes. The user for this reason will have to give the equipment that got to its life cycle to the suitable separate waste collection centres of electronic and Electrotechnical wastes, or to give it back to the seller or dealer when buying a new equipment of equivalent type, in terms of one to one. The suitable separate waste collection for the following sending of the disused equipment to recycling, the dealing or handling and compatible environment disposal contributes to avoid possible negative effects on the environment and on the people's health and helps the recycling of the materials the machine is composed of. The user's illegal disposal of the product implies the application of administrative fines as stated in Law Decree n. 22/1997" (article 50 and followings of the Law Decree n. 22/1997).

1.3 PREPARATION BY THE PURCHASER

01

Preparation of the installation site.

The purchaser must prepare the surface on which the machine will stand suitable to support the machine weight (see the installation Chapter).

ELECTRICAL REQUIREMENTS

The mains power installation must comply with the safety regulations and standards in force in the country of installation and must include an efficient earth system. An omnipolar cut-off device must be installed on the power line upstream of the machine.



The power wires must be sized according to the maximum current required by the machine to ensure a total voltage loss under full load of less than 2%.

PLUMBING REQUIREMENTS

Prepare a suitable drain and a mains that supply water a maximum hardness of 3/5 French degrees (60/85 ppm).



1.4 SYMBOLS

- A General hazard
- B Electrical shock hazard
- C Burns hazard
- D Hazard of damage to the machine
- E Operation reserved for the qualified technician, in compliance with current standards

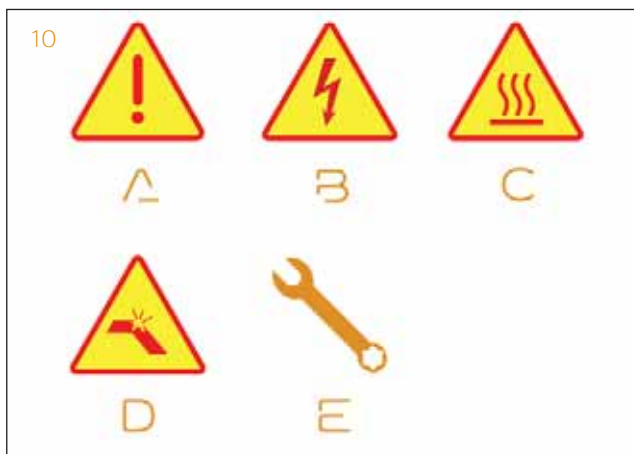

1.5 RESIDUAL RISKS

Although the manufacturer has provided mechanical and electrical safety systems, dangerous areas persist during the use of the machine:

- Coffee dispensing group.
- Steam wand.
- Hot water wand.
- Cup holder surface.



1.6 MACHINE RECEIVING

1.6.1 TRANSPORT

The machine is transported on pallets containing several machines inside cartons strapped to the pallet.

Operators performing any shipping or handling operations must wear gloves, safety shoes and overalls with elasticized cuffs.

The machine must be moved by 2 or more operators.

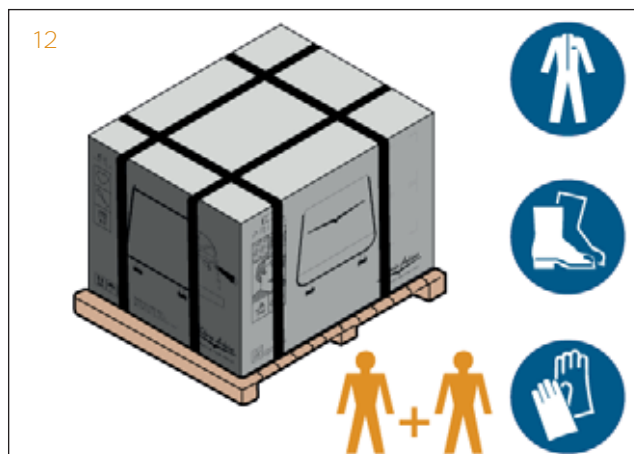

WARNING

Failure to respect current safety regulations and standards on lifting and handling materials absolves the Manufacturer from all liability for possible damage to person or things.



WARNING

During the entire handling operation, the operator must make sure no one or nothing is inside the operating area.

1.6.2 MOVEMENTS

Slowly lift the pallet about 30 cm from the ground and reach the loading area. After checking that there are no obstacles, things or people, proceed with the loading. Once you arrive at your destination, always with a suitable lifting device (e.g. forklift), after making sure that there are no things or people in the unloading area, take the pallet to the ground and move it about 30 cm from the ground, until to the storage area.

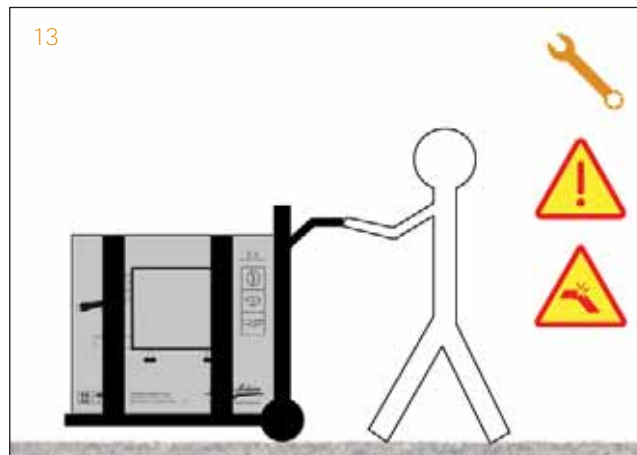

1.6.3 STORAGE

The package containing the machine must be stored away from atmospheric agents. Before performing the following operations, make certain that the load is in stable and will not fall when the straps are cut. Wearing gloves and safety shoes, the operator must cut the straps and store the product. During this operation, see the product technical features for the weight of the machine being stored and proceed as necessary.

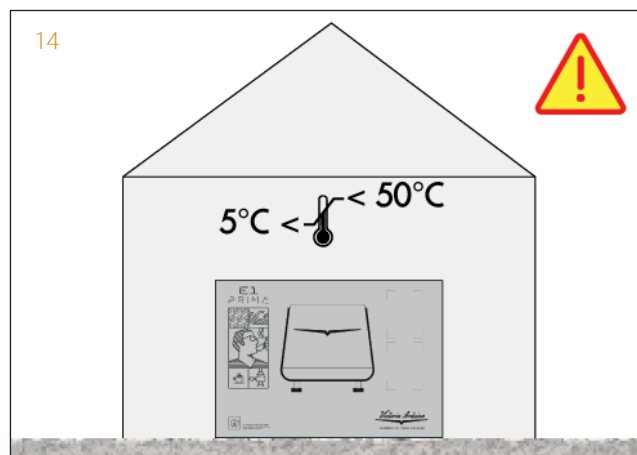

1.6.4 UNPACKING

Once the machine has been released from the pallet or container, do not pollute the environment with these items.



01 1.7 CONTENTS CHECK

Upon receipt of the box, check that the packaging is intact and visually undamaged. Inside the packaging must be the instruction manual and the relative kit. In case of damage or faults, contact your local dealer. For any communication, always communicate the serial number. The communication must be carried out within 8 days from the receipt of the machine.

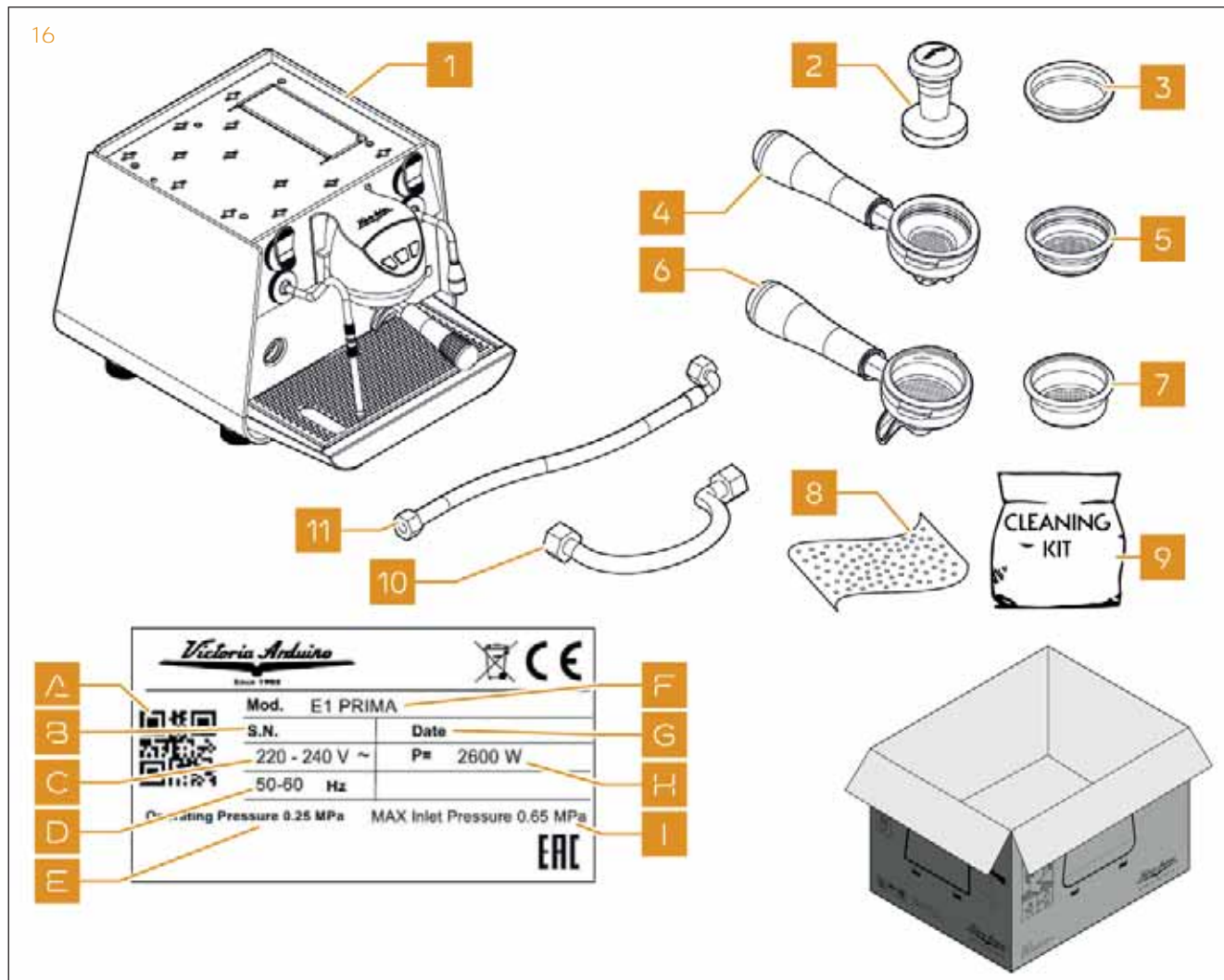

- 1 Machine (example image)
- 2 Coffee tamper
- 3 Blind filter
- 4 Single filter-holder
- 5 Single filter
- 6 Double filter-holder
- 7 Double filter
- 8 Microfibre cloth
- 9 Cleaning kit
- 10 Filling pipe 3/8" (1 unit)
- 11 Draining pipe 3/4" (1 unit)

- A QR code
- B Serial number
- C Power supply
- D Frequency
- E Operating pressure
- F Model and version
- G Production date
- H Power
- I Max inlet pressure

The machine internet page can be accessed directly through the QR code. Download and install one of the Apps to read QR codes on a mobile device. Start the App and position the camera in front of the code so that it can be clearly seen. Wait some time while the App processes the result and shows the internet page of the machine on the touch screen.



02

FIRST INSTALLATION AND PRELIMINARY OPERATIONS



INDEX

02	FIRST INSTALLATION AND PRELIMINARY OPERATIONS	19
2.1	POSITIONING	20
2.2	TECHNICAL CHARACTERISTIC	21
2.3	WATER SPECIFICATIONS	22
2.4	ELECTRICAL SPECIFICATIONS	22
2.5	WATER SUPPLY	23
2.5.1	TANK VERSION	23
2.5.2	DIRECT CONNECTION VERSION	24
2.5.3	SOFTWARE SWITCH FROM TANK TO DIRECT CONNECTION VERSION AND VICE-VERSA	25
2.5.4	DIRECT WASTE WATER SYSTEM	26
2.6	PROCEDURE OF FIRST POWERING ON	27
2.7	WATER INPUT PRESSURE FOR DIRECT CONNECTION VERSION	29
2.8	ADJUSTMENT OF THE PRESSURE	29
2.9	HOT WATER ECONOMISER ADJUSTMENT	30
2.10	BASIC PROGRAMMING	30



Prior to installation please carefully read the safety instructions in this manual. The company cannot be held responsible for damage to persons or property arising from non-compliance with safety regulations, either during installation or maintenance of the machine described in this manual.

02



WARNING

Place the machine in an area where all risks of malfunction can be avoided.



WARNING

Never install in areas where the machine may be subject to jets of water.

2.1 POSITIONING

Once the packaging has been removed and the integrity of the machine and accessories have been checked, place the machine on a horizontal surface.

- Position the machine on a horizontal plane at least 100 mm around the machine for proper ventilation.
- Ensure that it is correctly levelled.
- Rotating the feet.

RISK OF POLLUTION

DO NOT DISPOSE PACKAGING in the environment.

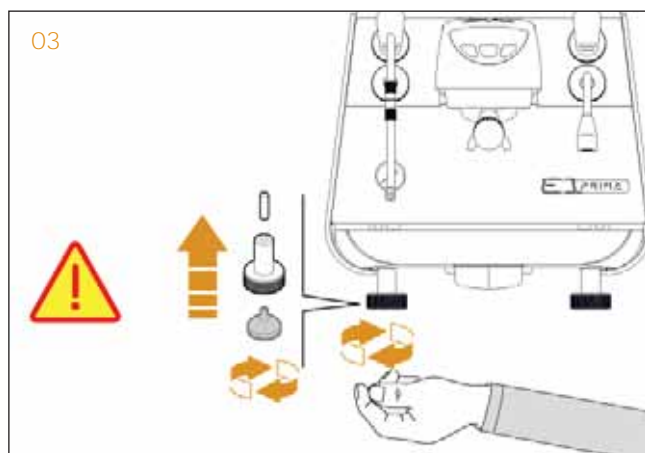
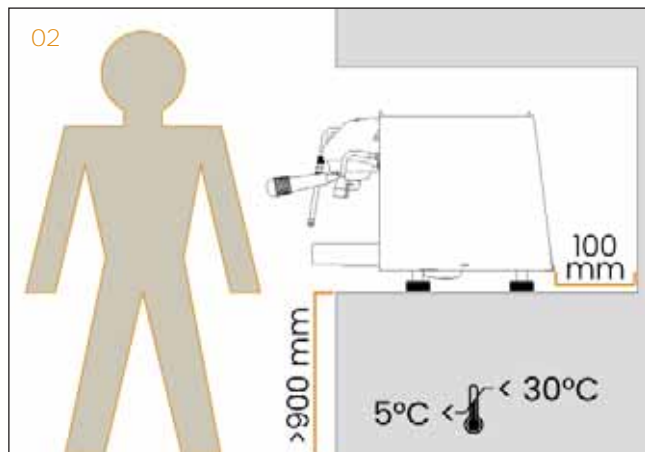

2.2 TECHNICAL CHARACTERISTIC

ELECTRICAL DATA		220-240 V~ 50-60 Hz 2600 W 110 - 120 V~ 50-60 Hz 1800 W 220-240 V~ 50-60 Hz 1800 W (AUS/NZ)
STEAM BOILER CAPACITY	l	1,5
NET WEIGHT	kg / lb	36 / 79,37
GROSS WEIGHT	kg / lb	47 / 102,62
DIMENSIONS		
X	mm / inch	410 / 16,14
Y	mm / inch	380 / 14,96
Z	mm / inch	510 / 20,08

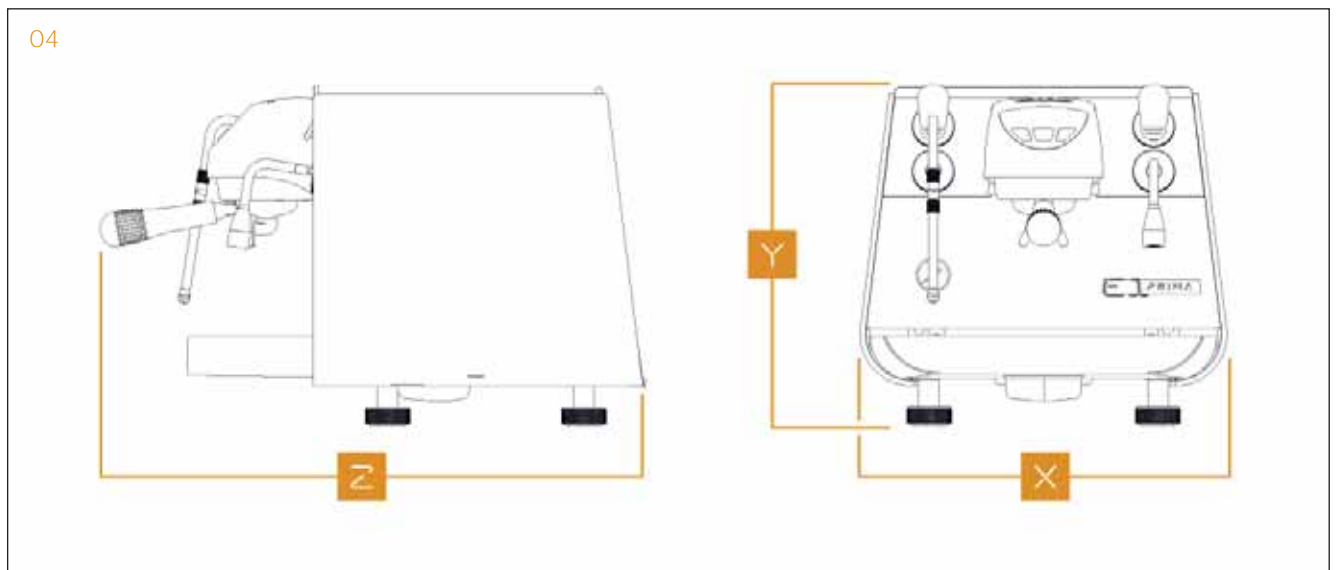

2.3 WATER SPECIFICATIONS

Monitoring of water recipe to keep it within required levels and maintenance of filtration system is the user's responsibility.

Failing to meet and maintain water at the following levels will void the entire warranty.

Total hardness	ppm	50 - 60
Waterline pressure	bar	2 - 5 (cold water)
Minimum flow	l/hr	200
Chloride	micron	< 1.0
Alkalinity	ppm	10 - 150
Total dissolved salts (TDS)	ppm	50 - 250
Chloride	mg/L	< 0.5
pH		6.0 - 8.0

2.4 ELECTRICAL SPECIFICATIONS

EI PRIMA is available with 220 V 50-60 Hz mono phase.

Plug the machine into the main socket.



Prior to connecting the machine to the electrical mains, assess that the voltage shown on the machine's data plate corresponds with that of the mains.

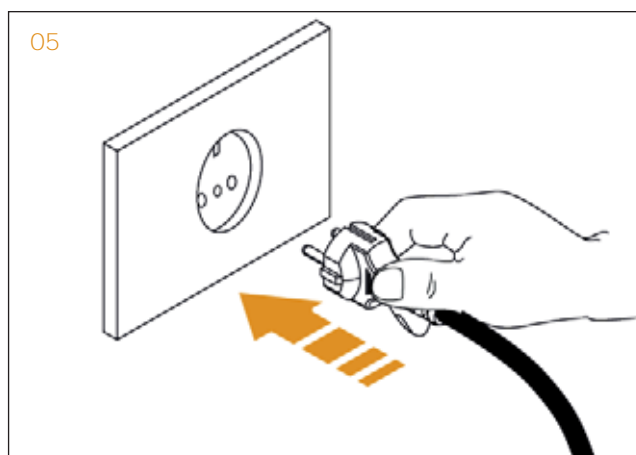

2.5 WATER SUPPLY

The machine arrives in tank version but it is always supplied with direct connection components.

2.5.1 TANK VERSION

To prepare the machine to work with tank, proceed as it follows:

1 Open the tank cover and remove the tank.

2 Wash the tank with soap and water and then fill it with water.

3 Make sure the outside of the tank is dry and reinsert it correctly pushing it.



WARNING

Use a proper water following the water specification in paragraph 2.3.

NOTE

If it is needed to use it with tank, follow the installation procedure in paragraph 2.5.1; otherwise, if the direct connection is preferred, follow the procedures in paragraphs 2.5.2, 2.5.3 and 2.5.4.

02

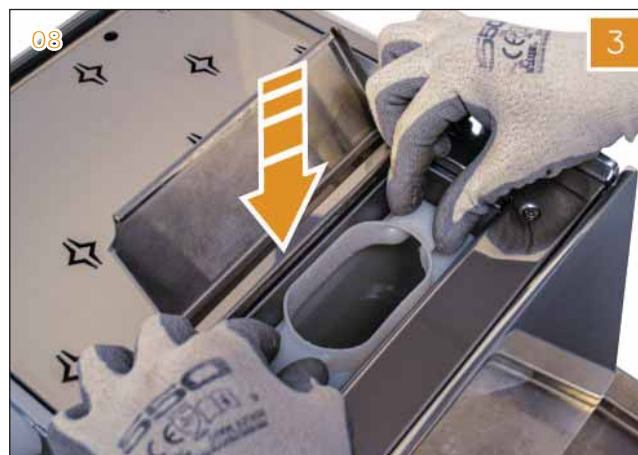

2.5.2 DIRECT CONNECTION VERSION

02

The machine is always supplied with a 1.5 meters long loading pipe (A) and with a 3/8 inch connection.

For the waterline, fitting is straight on one side and with an entrance at 90° angle on the other side. The pipe is provided with tapered fittings therefore it is not necessary to use Teflon tape on the fitting.

To connect the machine to the waterline, connect the supplied pipe from the water mains supply to the union under machine (B).

NOTE

It is advisable to install a softener (1) and then a mesh filter (2) on the external part of the plumbing system, during preliminaries and after levelling the machine.



WARNING

Avoid throttling in the connecting pipes. Assess that the drain pipe (3) is able to eliminate waste.

NOTE

For a correct functioning of the machine the water works pressure must not exceed 5 bars. Otherwise, install a pressure reducer upstream of the softener; the internal diameter of water entrance pipe must not be less than 6 mm (3/8").

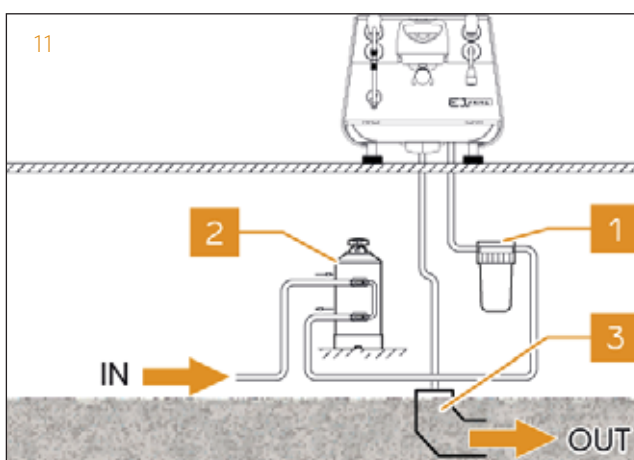

- 1 Softener
- 2 Mesh filter
- 3 Drain Ø 50 mm

2.5.3 SOFTWARE SWITCH FROM TANK TO DIRECT CONNECTION VERSION AND VICE-VERSA

Once having set the machine with the direct connection water, it is needed to perform the software switch from tank to direct connection version.

Proceed as it follows:

- 1 Switch OFF the machine from the main switch positioned to the bottom on the right.
- 2 Press and hold the **1A** and **1C** buttons while switching the machine ON from the main switch. The tank icon (**T**) will flash for 3 times (confirmation signal).

NOTE

The same procedure works also in case it is needed to change back from direct connection to tank version.

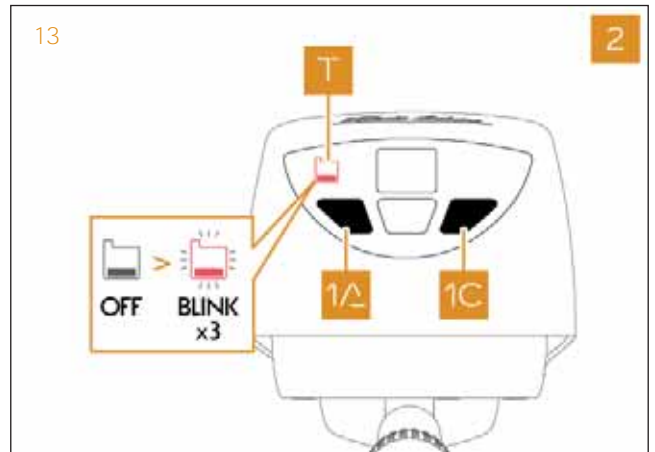
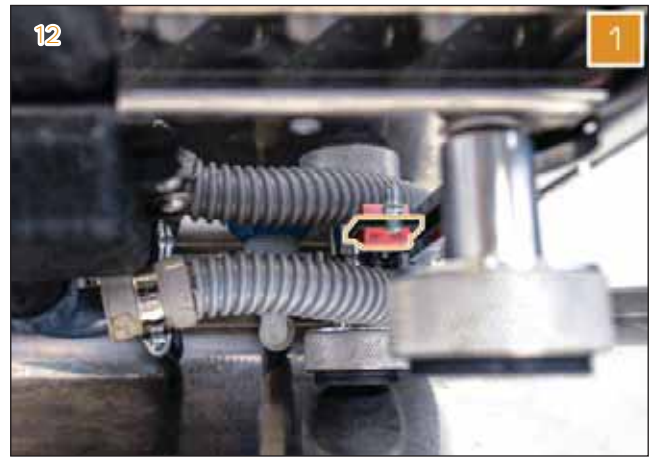

2.5.4 DIRECT WASTE WATER SYSTEM

The drip tray can collect around 1 litre of waste water. In case it is preferred to use a direct waste water system, proceed as it follows:

- 1 Connect the supplied waste water pipe to the supplied joint and use a Philips screwdriver to tighten.
- 2 Connect the waste water pipe and the joint to the waste water system by manually screwing it to the union.
- 3 Remove the drip tray and drill it following the **instruction sheet 31002010** included in the packaging.

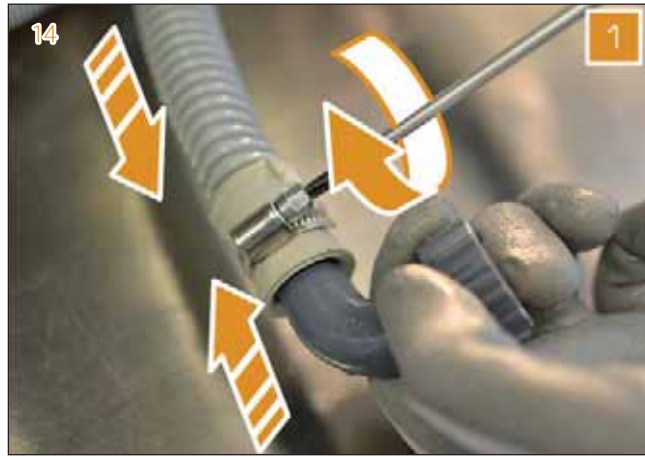

2.6 PROCEDURE OF FIRST POWERING ON

When first powering ON the machine, proceed as it follows:

- 1 Switch ON the machine from the main switch positioned to the bottom on the right.
- 2 As first powering ON, the machine enters the FILLING procedure: the message 'FI' appears on the group display and the group keys flash fast.
- 3 When the group keys flash more slowly, press and hold the keys **1A** and **1C** together until procedure is engaged. The machine will start the pump to fill the coffee boiler for 20 seconds and water will come out from the group.

NOTE

If this cycle is interrupted due to a power outage, or if the machine is accidentally switched OFF from the main switch, the next time the machine is switched ON, the cycle will automatically start again.

NOTE

If the cycle does not end with the outflow of water from the group, it is reasonable to turn the machine OFF immediately and restart the procedure from step 1, to check whether or not there are problems filling the coffee boiler.

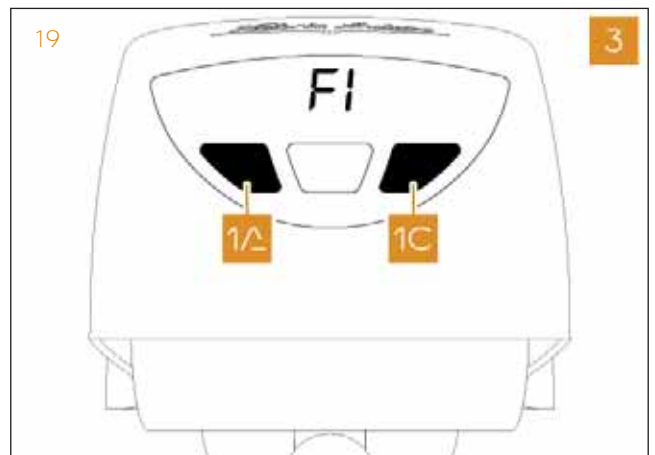
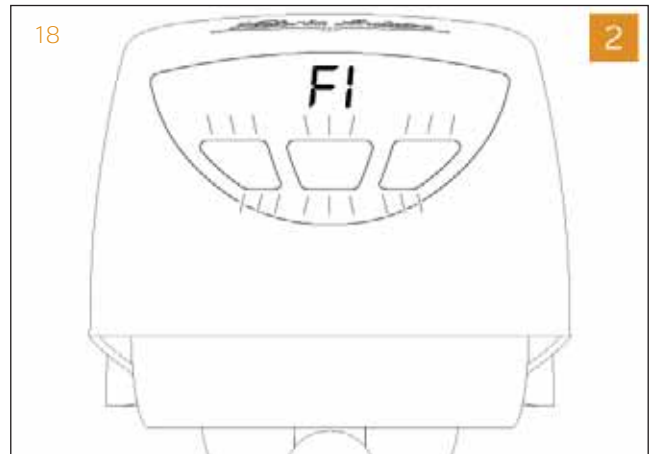

NOTE

02 If any alarm appears on the group display, the machine recognizes that there is a problem. Refer to chapter 10 to know how to proceed.



WARNING

If the boiler is not completely filled with water, this could damage the coffee boiler heating element.



WARNING

To repeat the filling of the coffee boiler (e.g., after a coffee boiler or group maintenance), it is needed to enter again the FILLING procedure, as described in chapter 9.

Once the coffee boiler filling procedure ends, the machine will automatically proceed with the auto-fill function of the steam boiler, hence it will start the pump to reach the correct water level.

If after 90 seconds the water level has not been reached, alarm **A2** appears on the group display because the motor protection starts to function.

Furthermore, this system that protects the motor is also utilised to stop the pump from working if there is no water available (e.g., the upstream tap is closed).

Check the inlet water flowing (e.g., the tank is correctly filled and placed) and then turn the machine OFF and ON to continue the flow of water to the steam boiler.

20

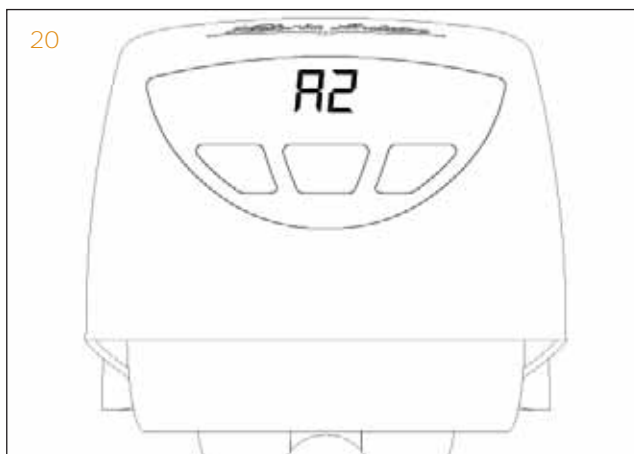

2.7 WATER INPUT PRESSURE FOR DIRECT CONNECTION VERSION

Check with the smartphone app **Victoria Arduino E1** that the water input pressure is between 0 and 5 bar.

NOTE

If the pressure is more than 5 bar, insert a pressure reducer upstream to ensure a value between 0 and 5 bar.

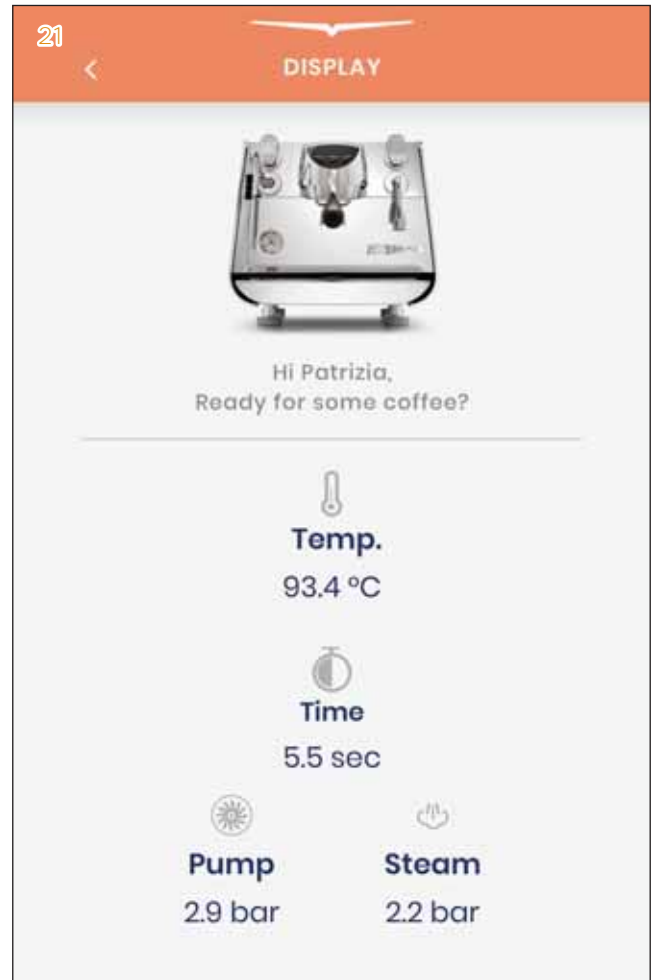

02

2.8 ADJUSTMENT OF THE PRESSURE

The pressure of the machine must be set while the coffee is brewing. While coffee is delivered, check with the smartphone app **Victoria Arduino E1** that the value reaches 9 bar, the optimum value.

In the event that it would be necessary, use the knob located below the machine to make an appropriate adjustment.

Turning the knob clockwise raises the pressure, turning it counter-clockwise decreases the pressure.

NOTE

By factory the pump pressure is set to reach 9 bar.



2.9 HOT WATER ECONOMISER ADJUSTMENT

02

NOTE

This operation can be carried out while the machine is turned ON.

The hot water mixer serves to adjust the temperature of the water leaving the wand and to optimise system performance. To set the hot water economy device, use a screwdriver on the screw in the top part of the machine, as shown in the figure.

Turn it **CLOCKWISE / COUNTER-CLOCKWISE** to **INCREASE / REDUCE** the temperature of hot water.

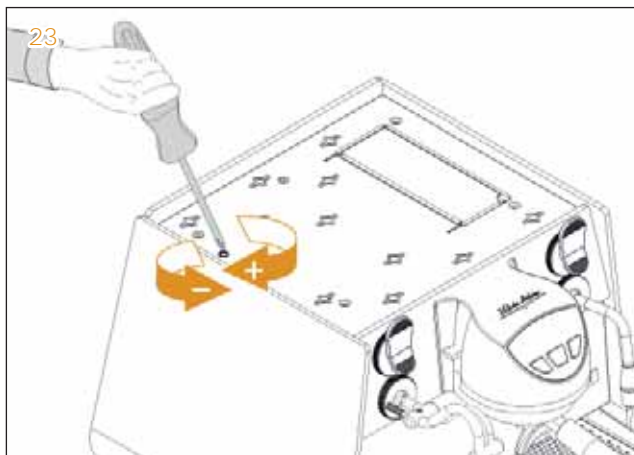

2.10 BASIC PROGRAMMING

The machine comes already provided with the following main default settings:

- COFFEE TEMPERATURE (group and coffee boiler): 93.4 °C
- SINGLE SHOT DOSE **1A**: 40 cc
- DOUBLE SHOT DOSE **1C**: 70 cc
- HOT WATER UP DOSE: 5.5 seconds
- HOT WATER DOWN DOSE: 7.0 seconds
- STEAM BOILER PRESSURE: 2.2 bar

For more information about the programming, see the Chapter 9.

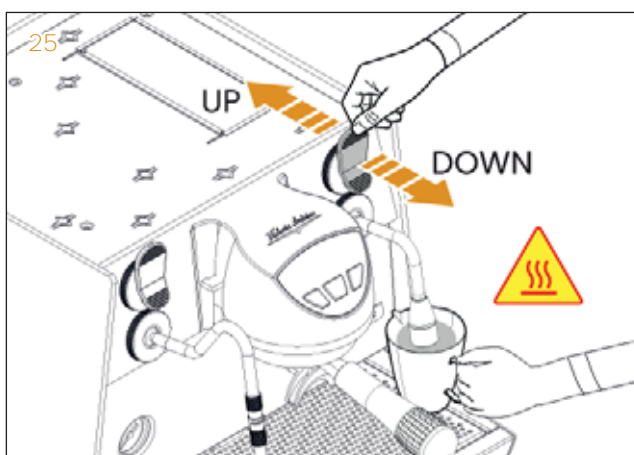
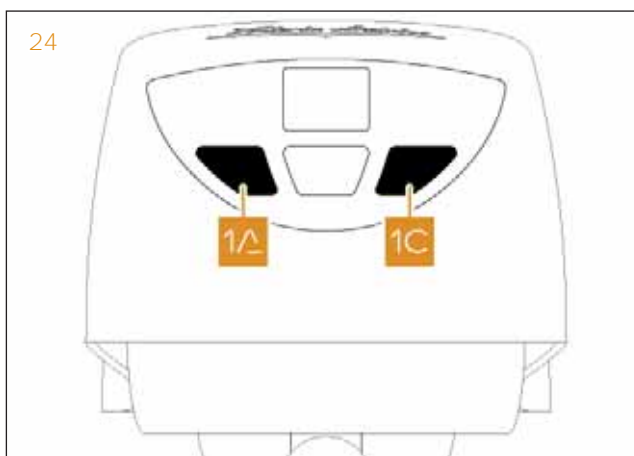

03

REMOVAL OF EXTERNAL SURFACE

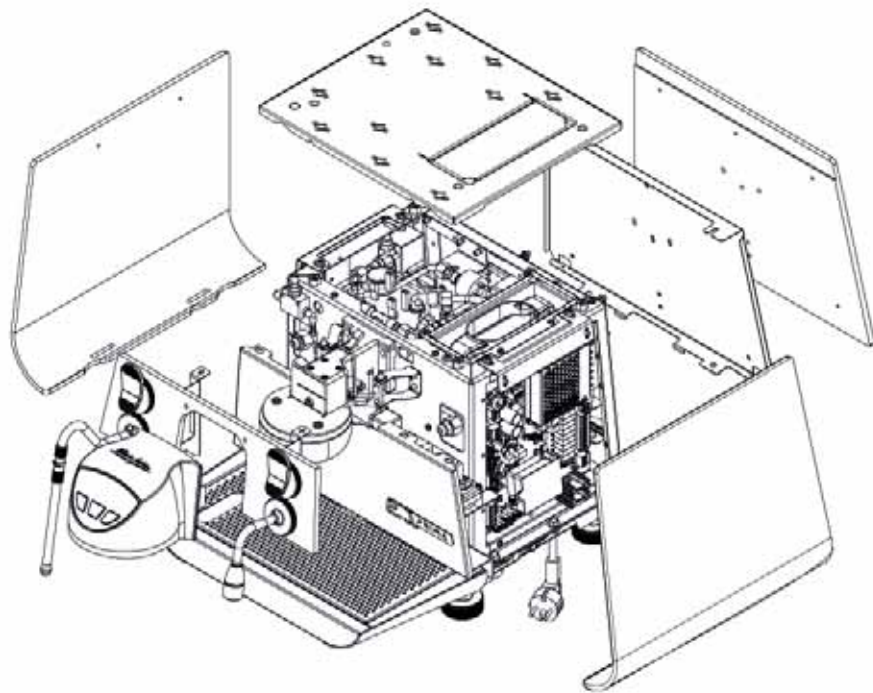

03

INDEX

03	REMOVAL OF EXTERNAL SURFACE	31
3.1	REMOVAL OF THE CUP HOLDER SURFACE	33
3.2	REMOVAL OF THE SIDE PANELS	34
3.3	REMOVAL OF THE REAR PANEL	35
3.3.1	DISASSEMBLE THE REAR PANEL	37
3.4	REMOVAL OF LOWER REAR PANEL	38
3.5	REMOVAL OF THE LOWER FRONT PANEL	39
3.6	REMOVAL OF THE GROUP COVER	41



Use gloves to protect against sharp or hot surfaces that you can bump against involuntarily during operations.

01



HOT AND CUTTINGS SURFACES

02



DANGER

03



DANGER

Before proceeding with the operations described in this chapter make sure that the machine is turned OFF and unplugged from the mains.

NOTE

Before proceeding with the removal of the panels it is advisable to clean and free up enough space where the machine parts will rest so that they are not be unintentionally damaged.



3.1 REMOVAL OF THE CUP HOLDER SURFACE

To remove the cup holder surface:

1 Utilising a Philips screwdriver, remove the 4 screws of the module.

2 Remove the panel.

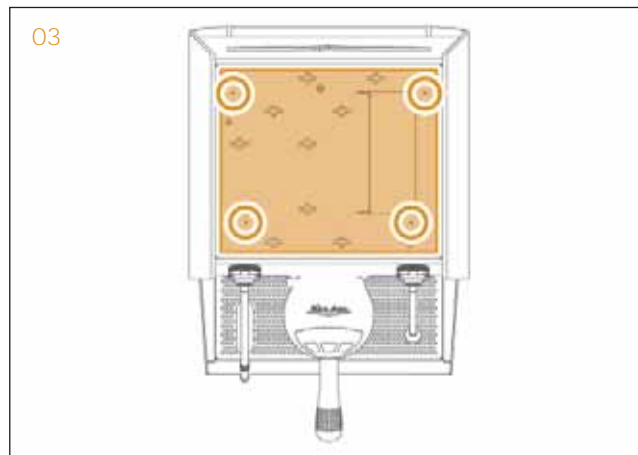

3.2 REMOVAL OF THE SIDE PANELS

The procedure is identical for each side panel.

03

To remove one side panel, it is necessary to:

1 Remove the cup holder surface.

2 Utilising a Philips screwdriver, loosen the screws on the upper part.

3 Put a hand below the side panel and with the other hand slide it out.

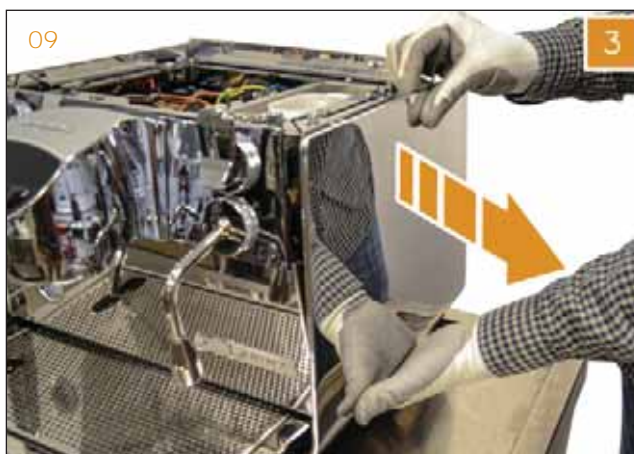
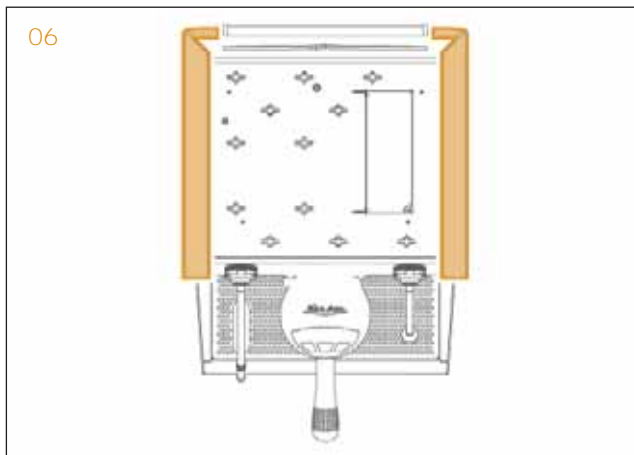

3.3 REMOVAL OF THE REAR PANEL

To remove the back panel it is necessary to:

1 Remove the cup holder surface.

2 Remove both side panels.

3 Utilizing a Philips screwdriver, loosen the two upper screws.

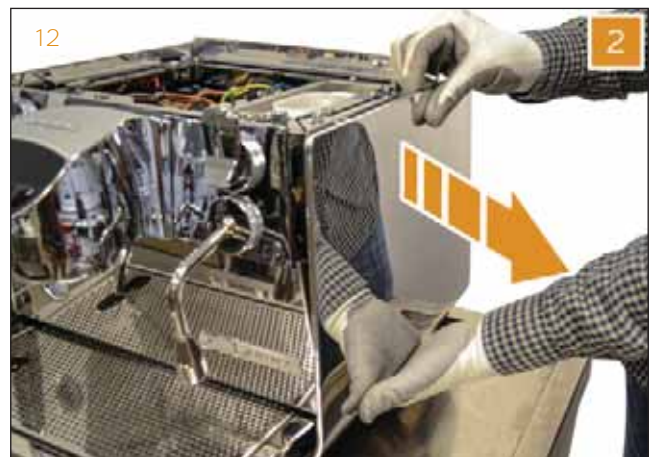
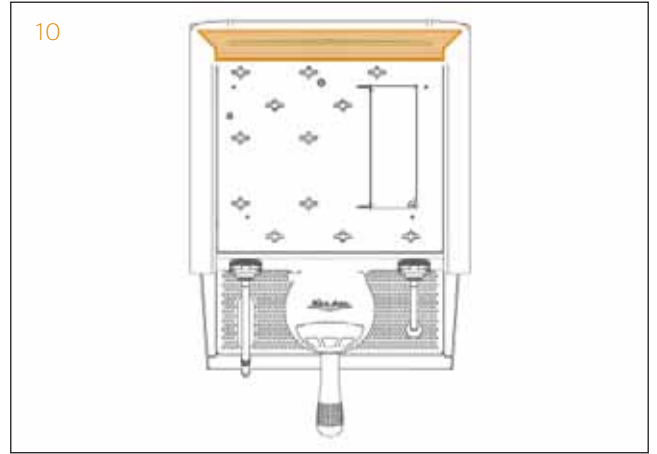

- 4 With a hand pull the high side of the panel and with the other hand lift it from the bottom.



- 5 Disconnect the LED bar before to completely remove the panel.

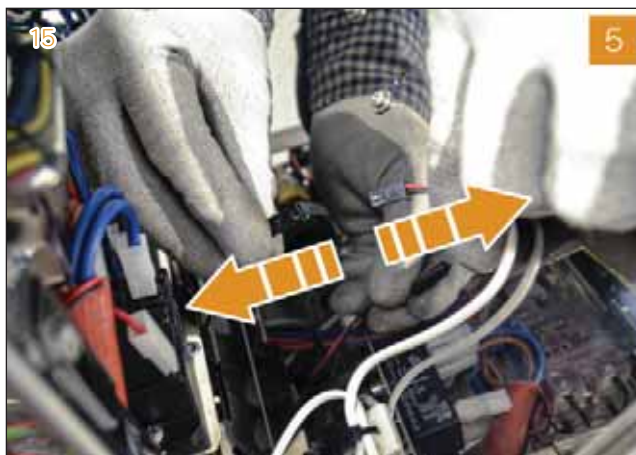

3.3.1 DISASSEMBLE THE REAR PANEL

The rear panel of **EI PRIMA** can be personalized.

To proceed it is necessary to disassemble it, as it follows.

- 1 Remove the rear panel as described in the previous paragraph.
- 2 Utilizing a Philips screwdriver, remove the three screws and take off the eagle.
- 3 Utilizing a 8 mm wrench, remove the six screws and disassemble the panel.

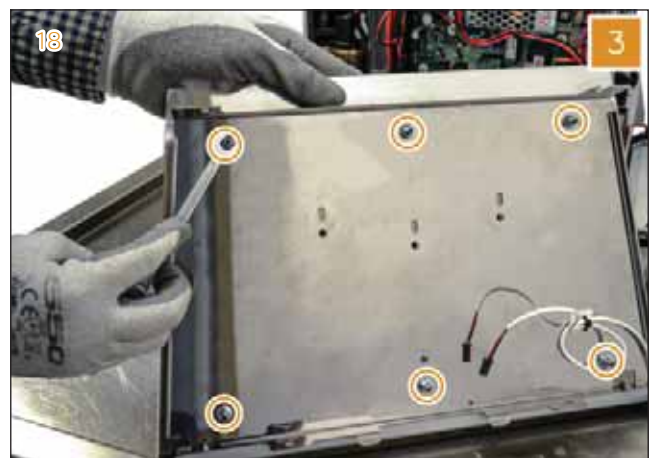
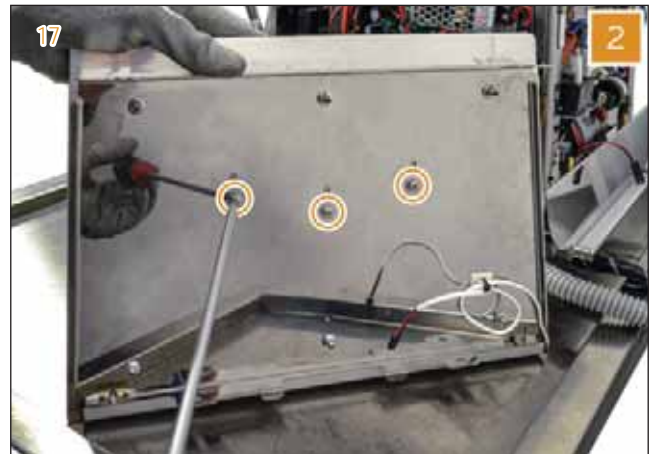

3.4 REMOVAL OF LOWER REAR PANEL

To remove the lower rear panel, it is necessary to:

03

1 Remove the rear panel as described in the previous paragraph.

2 Utilizing a Philips screwdriver, remove the two lateral screws.

3 Utilizing a Philips screwdriver, loosen the three screws on the bottom.

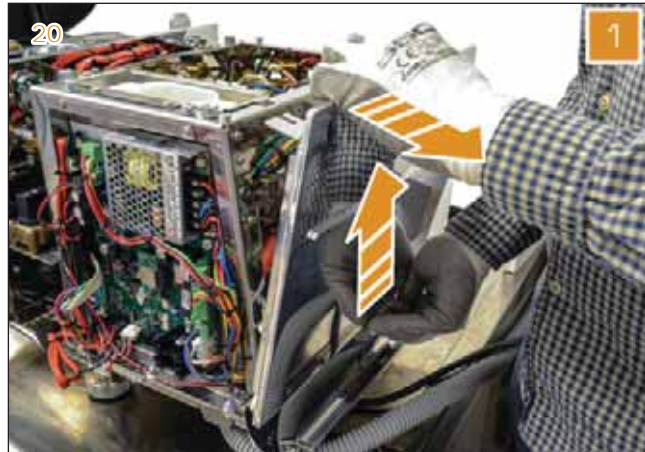
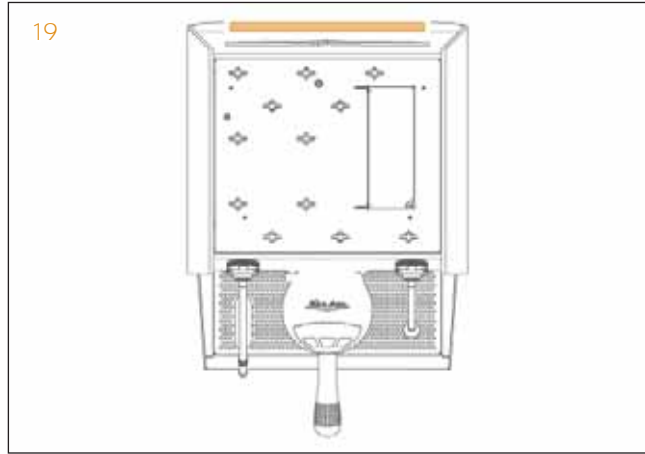

- 4 Using a 3 mm Allen Key, loosen the three screws to disassemble the panel.

NOTE

There is a washer between the screw and the panel.

3.5 REMOVAL OF THE LOWER FRONT PANEL

To remove the lower front panel, it is necessary to:

- 1 Remove the cup holder surface and both side panels .

- 2 Remove the work surface pulling out the drip tray.

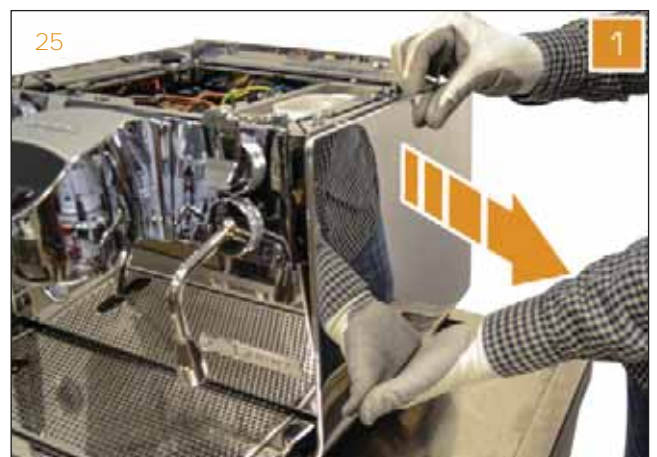
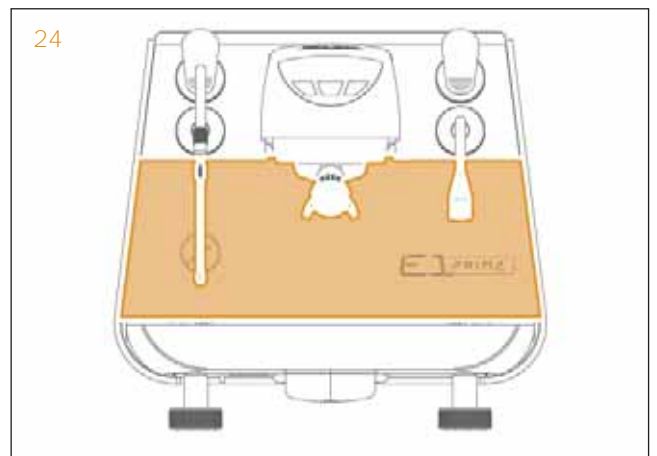
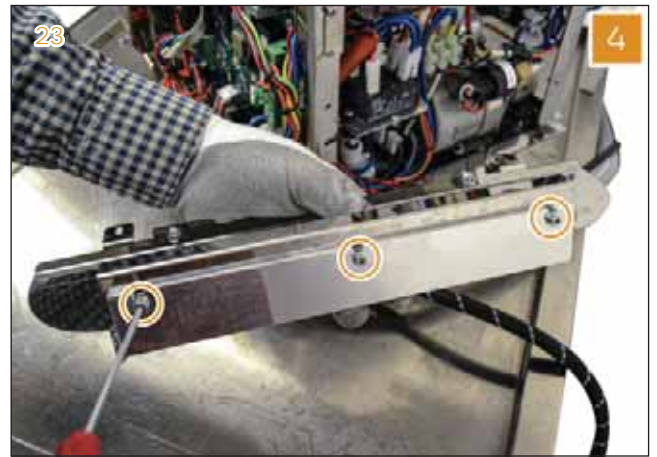

- Utilizing a Philips screwdriver, loosen the two side screws that keep the front panel in position.

NOTE

Owing to the shape of the panel, it is not necessary to loosen the screws totally.

- Lower the panel to free it from the fixing screws, rotate it from the top downwards and pull it out.

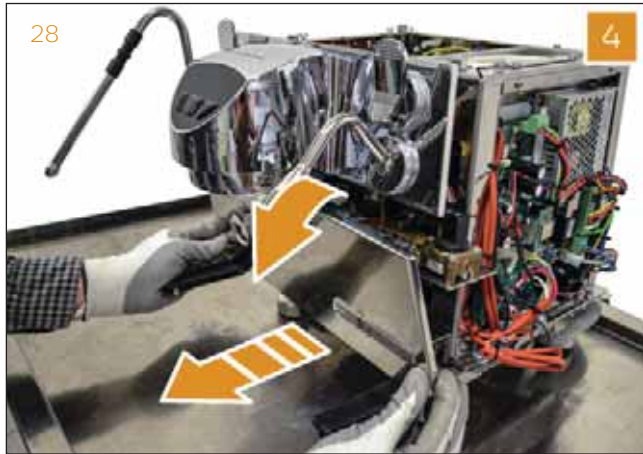
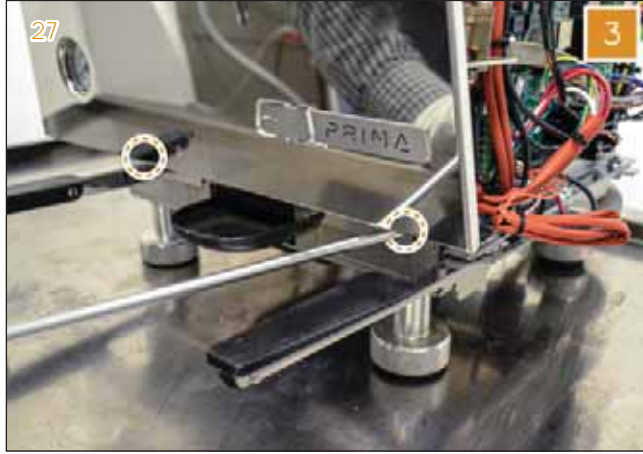

3.6 REMOVAL OF THE GROUP COVER

To access the group, proceed as it follows.

1 Remove the side panels, the drip tray and the lower front panel, as described in the previous paragraphs.

2 Utilizing a 3 mm Allen Key, partially unscrew the two screws holding the group cover.

3 Rotate the group cover from the top downwards to remove it from the machine.

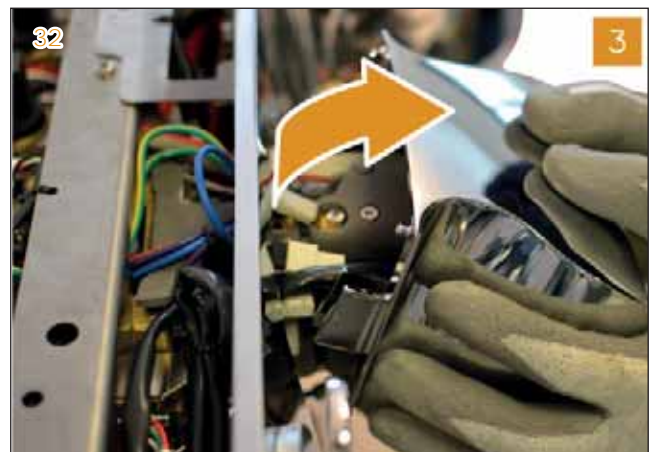
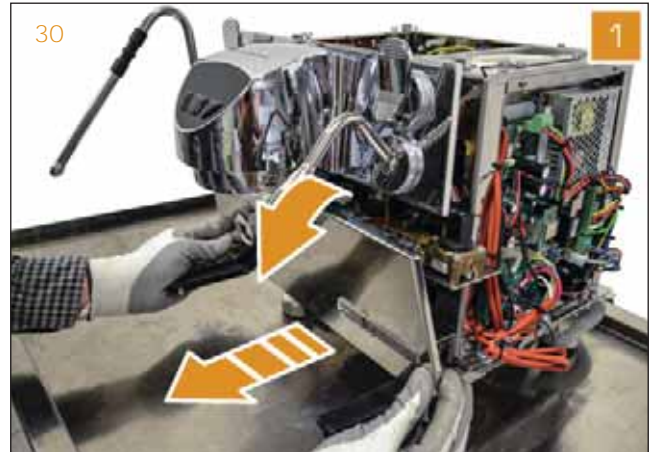
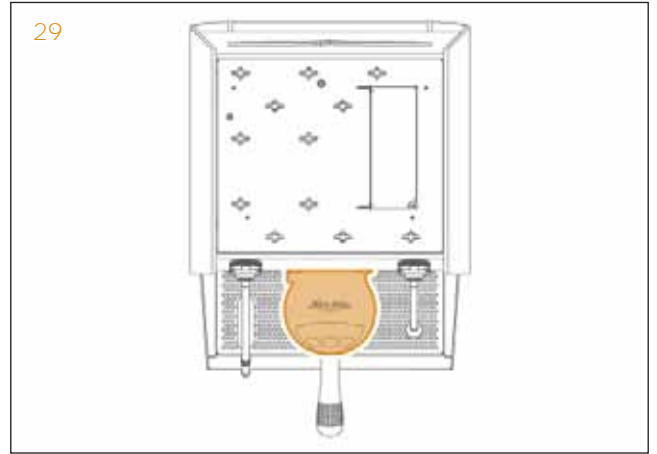

- 4 Check connections to memorize them and disconnect them.



03



DANGER

If the machine has been turn OFF recently, wear protective gloves.

For further information about operations on the group cover and service board, refer to Chapter 8.

34



HOT AND CUTTINGS SURFACES



04 INFUSION GROUP



■ Replace every 4-6 months

■ Replace every 12 months

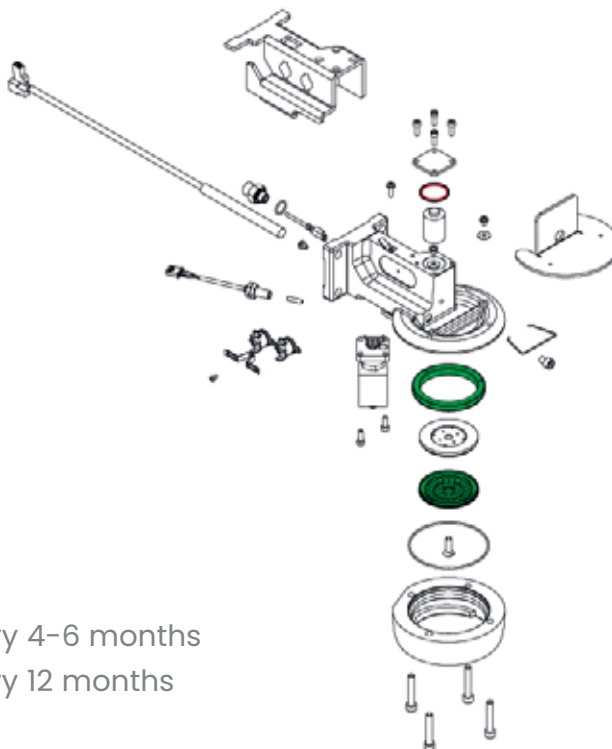

INDEX

04	INFUSION GROUP	43
4.1	REMOVAL OF SHOWER, PAVILION AND SEAL	46
4.2	FILTER HOLDER PRESENCE SENSOR	46
4.2.1	REMOVAL OF THE FILTER HOLDER PRESENCE SENSOR	47
4.3	REPLACING THE SEAL IN THE PRE-INFUSION CHAMBER	49
4.4	HEATING ELEMENT	50
4.4.1	REMOVAL OF THE HEATING ELEMENT	51
4.5	TEMPERATURE PROBE	53
4.5.1	REMOVAL OF THE TEMPERATURE PROBE	54
4.6	HIGH-LIMIT THERMOSTATS	55
4.7	COFFEE VALVE	56
4.7.1	REDUCING OF THE COFFEE BOILER INNER PRESSURE	56
4.7.2	REMOVAL OF THE COFFEE VALVE	56



The infusion group is part of the **NEO** (New Engine Optimization), that guarantees high performance while reducing the energy consumption of the machine. Hence this group is different from common systems with thermosiphon circulation. In fact, the temperature of the group is ensured by the presence of a heating element cartridge. In addition, the thermal insulation prevents heat dispersion.

The group is equipped with:

- A heating element cartridge of 300 W;
- A temperature probe that communicates with the control unit;
- Two 135°C high-limit thermostats connected in series with the heating element;
- A three-way solenoid valve called coffee valve.

The group section shows:

- A Water supply into the group.
- B Heating element.
- C Coffee valve.
- D Pre-infusion chamber.
- E Water outlet.

The machine is provided by the SIS (Soft Infusion System). It optimizes the extraction and compensates any tamping errors so that it reduces waste and makes regularly perfect coffees. It is based on the pre-infusion chamber, that increases the time in which water without pressure wets the coffee cake to provide a uniform extraction. A cylinder in the chamber limits the space and the dripping of water after the end of extraction.

How does the water flow work? The water enters the group (A) and the coffee valve lets it pass through (C). Then the water fills the pre-infusion chamber in about 3 seconds (D) and, in the meantime, the coffee cake is reached by the water (E) and is naturally wet. Once the chamber is filled, the pressure of 9 bar reaches the coffee, initiating the extraction into the cup.

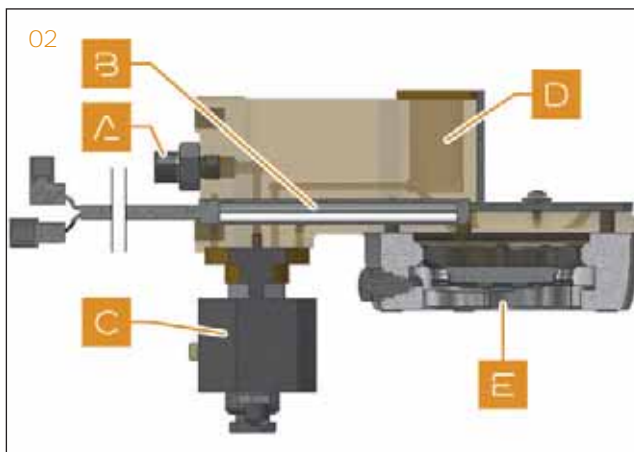

The last part of the infusion group is houses a pavilion, a shower and underpan seal. The pavilion distances the shower from the coffee, according to the need for different thicknesses. The machine comes with 3 mm pavilions.

The shower is the interface between the coffee and the machine, preventing the coffee from rising inside the machine.

Shower and pavilion tend to get dirty and must be removed and cleaned at least weekly. Furthermore, they must be replaced periodically.

The underpan seal prevents water from coming out from the sides of the pavilion and reach the capsule unevenly or spill from the filter holder. Since the material is plastic and exposed to high temperatures, the seal must be replaced regularly because it tends to deform and lose elasticity.

 **DANGER**

Before proceeding with the operations described in the chapter make sure that the machine is turned OFF.

 **WARNING**

If the machine was turned OFF recently, protect yourself with thermal insulation gloves.



4.1 REMOVAL OF SHOWER, PAVILION AND SEAL

To remove the shower and pavilion it is sufficient to loosen the central screw under the group.



To change the seal use an awl or a slim flat-head screwdriver and at first remove one edge of the seal and then remove it entirely. If the group is worn out just insert shims under the seal so as to reduce the stroke of the filter holder.



4.2 FILTER HOLDER PRESENCE SENSOR

The filter holder presence sensor (A) informs the control unit about the presence, or not, of the filter holder in the infusion group. In this way it permits the auto-purge feature.

It is visible in the back of the group head and comes out in the inner of the group head.



NOTE

When the filter holder sensor is functioning, an orange light means the presence of the filter holder, while no light means its absence.



PROBLEMS

The sensor could not work properly.

Example:

- 1 The light is always orange, as the sensor feels the filter holder presence, also in absence of it: sensor in short circuit, needs to be replaced.
- 2 The light is mostly OFF, and it is ON only with some movement of the filter holder. It could mean that the sensor is not properly flush with the inner of the group head: needs to be moved closer.

4.2.1 REMOVAL OF THE FILTER HOLDER PRESENCE SENSOR

To remove the sensor, it is necessary to:

- 1 Remove the cup holder surface, the side panels, the drip tray, the lower front panel and the group cover, as explained in Chapter 3.
- 2 Cut the clamp and unplug the sensor wire from its extension.
- 3 Cut the clamp of the sensor wire and extract the wire.

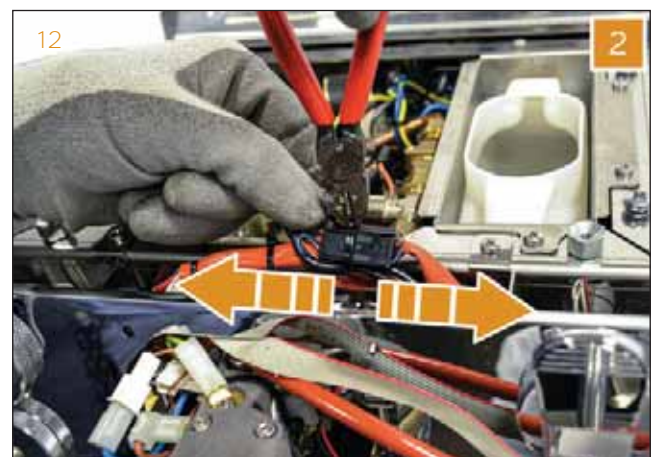
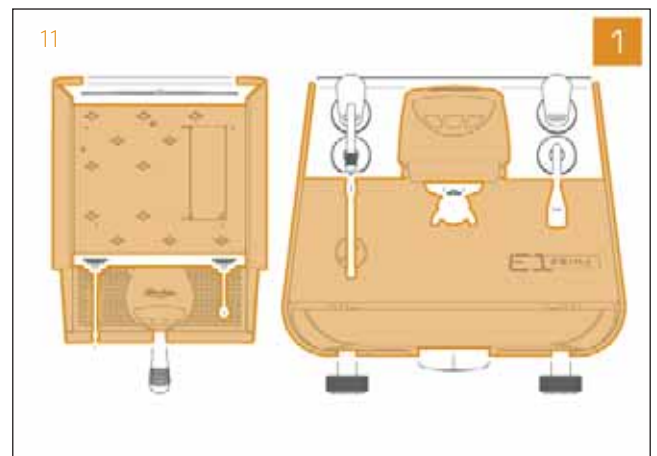

- 4 Utilizing a 13 mm wrench, loosen the sensor fixing nut.



- 5 Utilizing an adjustable wrench, slide out the sensor.

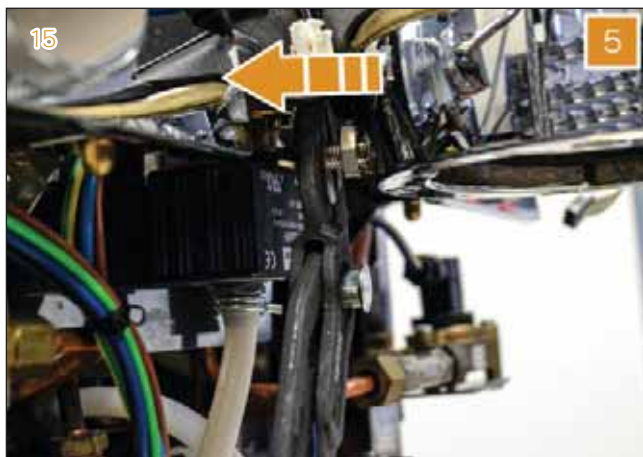

WARNING

When the filter holder sensor is reinserted, make sure it is flush with the inner of the group head and verify the proper functioning.

NOTE

To move the sensor closer, in order it is flush with the inner of the group head, follow steps 4 and 5 of the removal procedure and, when the position is fine, tighten the sensor fixing nut.

4.3 REPLACING THE SEAL IN THE PRE-INFUSION CHAMBER

The pre-infusion chamber is sealed by a cover fixed with four hex screws. Under the cover there is a seal that should be changed annually, in fact, like all seals, it may deteriorate in time and lose elasticity.

WHEN TO REPLACE IT

The seal must be replaced annually or when there is a leak from the pre-infusion chamber.

HOW TO REPLACE

1 Remove the cup holder surface, the side panels, the drip tray, the lower front panel and the group cover, as explained in Chapter 3.

2 Remove the clip of the insulating cover.

3 Lift the insulation cover.

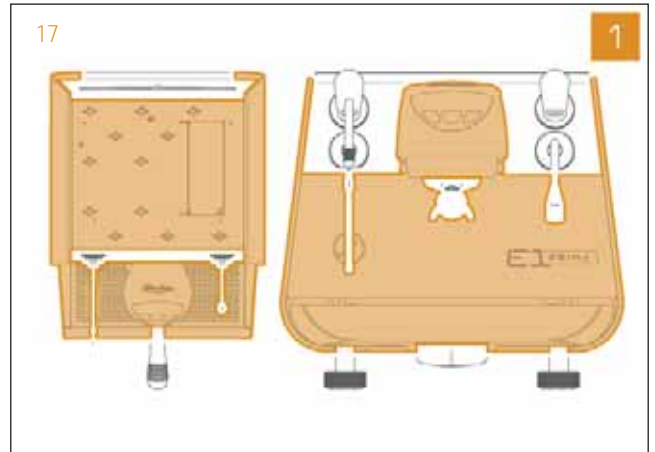

- 4 Utilizing a 3 mm Allen key, remove the four screws and open the chamber.



4.4 HEATING ELEMENT

The **NEO technology** manages temperatures of the "infusion group and coffee boiler" system, to give a proper extraction water temperature, in accord with what has been set in the programming as **MYCOFFEE Temperature**.

When the group heating element cartridge of 300 W needs to be powered ON, the control unit activates it.

To know when it is activated, it is possible to monitor LED placed on the control unit. The LED is labelled "**GR**".

Typical value of the heating element is approximately 185 ± 25 Ohm.

If the infusion group is not hot, use a tester to verify the heating element resistivity or its continuity.

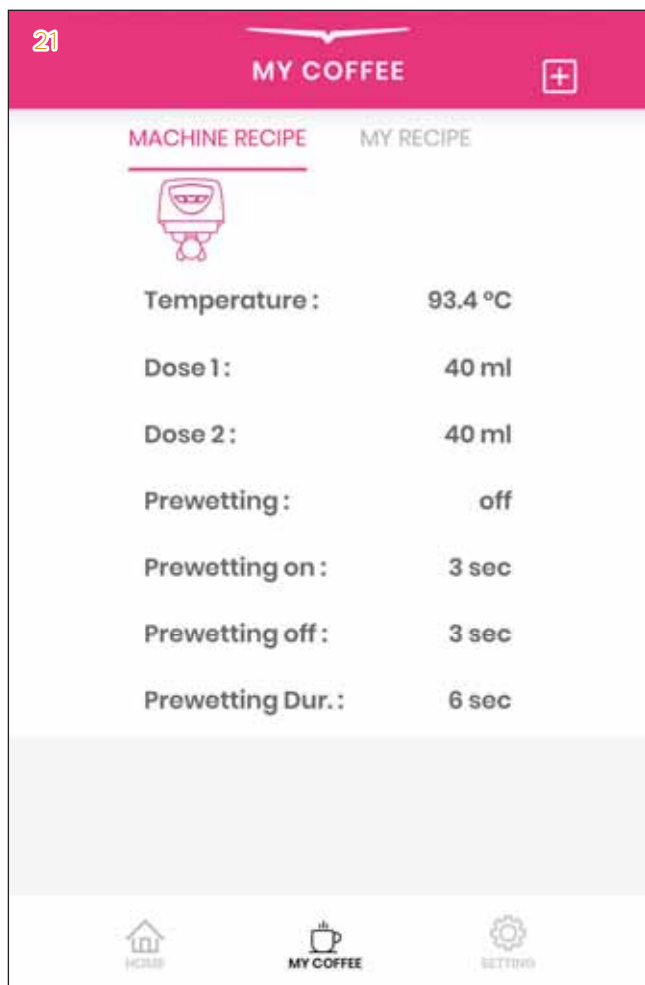

4.4.1 REMOVAL OF THE HEATING ELEMENT

The heating element cartridge is accessible from the rear wall that holds the infusion group.

To remove it, proceed as it follows.

1 Remove the cup holder surface, the side panels, the drip tray, the lower front panel and the group cover, as explained in Chapter 3.

2 Remove the coffee boiler as described in Chapter 6.

3 Following the orange cable, cut the clamps to release the cable.

4 Following the orange cable, disconnect the heating element from the neutral and from the high-limit thermostat.

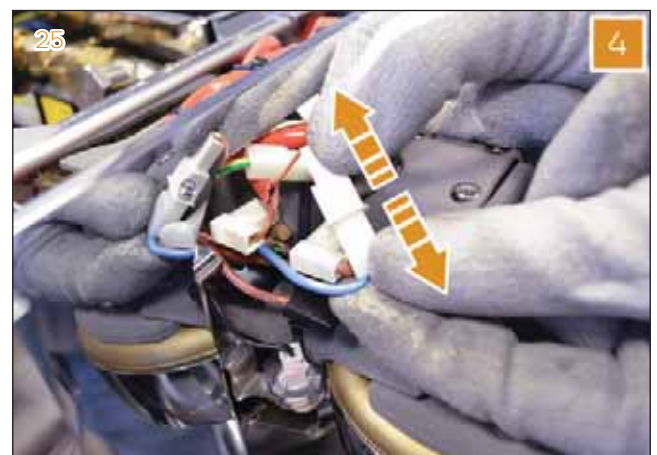
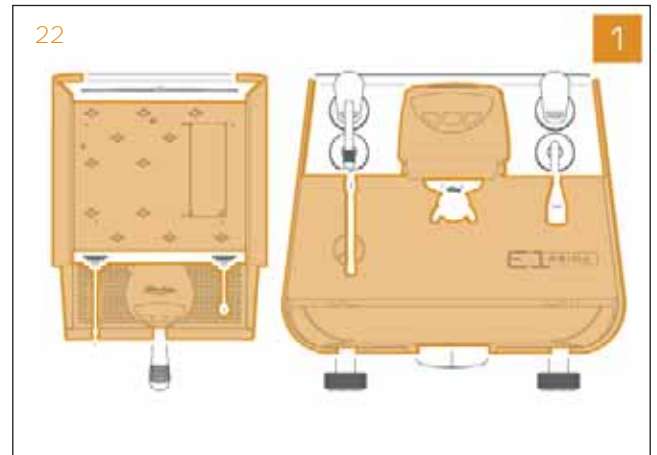

- 5 Utilizing a Philips screwdriver, loosen the screw that block the heating element.



- 6 Pull out the heating element.



4.5 TEMPERATURE PROBE

The temperature probe of the infusion group permits to the control unit to know the current temperature of the group.

Typical values of the temperature probe are approximately 1,1 kOhm at 25°C (room temperature) and approximately 1.4 kOhm at 90°C.

E1 PRIMA software can detect possible malfunctions of the temperature probe.

If alarms **A4** or **A5** (probes errors) are shown on the group display, this temperature probe could be involved.

Possible solutions are:

- 1 Check the probe cable and its connection to the control unit.
- 2 Replace the probe.

NOTE

For further information on the temperature probe errors, refer to Chapter 10.

28



29

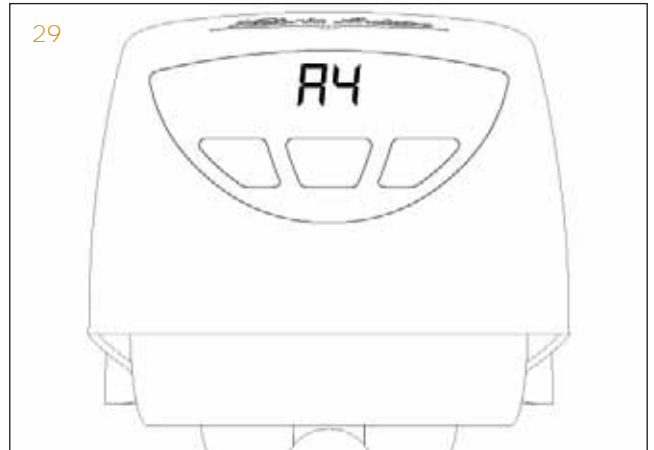

04

4.5.1 REMOVAL OF THE TEMPERATURE PROBE

To remove the temperature probe it's necessary to:

1 Remove the group cover, as described in Chapter 3.

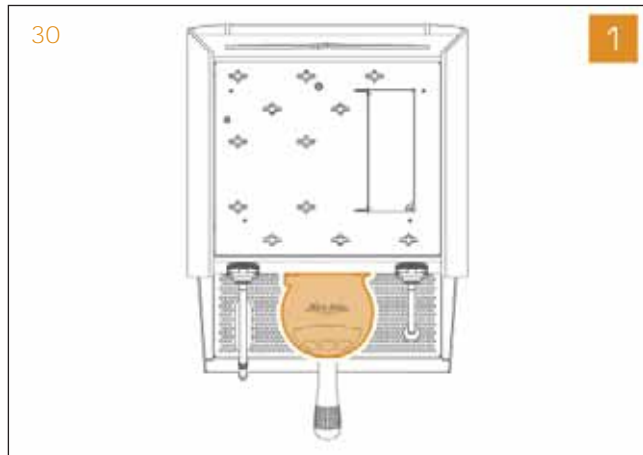

2 Disconnect the temperature probe from the central unit.

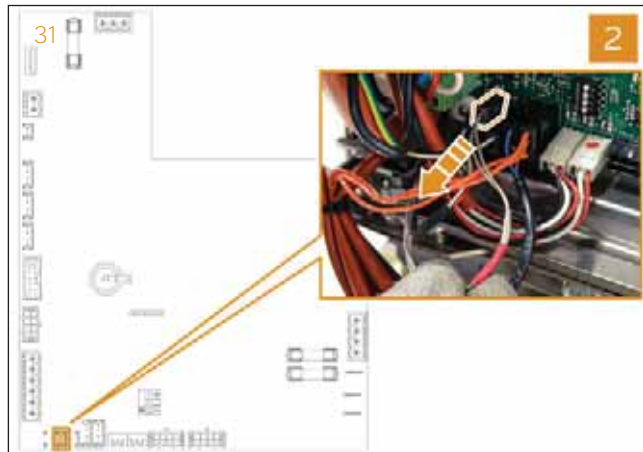

3 Utilizing a Philips screwdriver from the right side, remove the screw holding the probe to the group.



4.6 HIGH-LIMIT THERMOSTATS

The high-limit thermostats are connected in series with the heating element and opens the electrical circuit once the temperature limit of 135°C in the infusion group has been exceeded.

- If the heating element does not turn ON, check the continuity of the high-limit thermostat.
- If there is not continuity, rearm the high-limit thermostat pushing into the hole (A) by a small screwdriver.



4.7 COFFEE VALVE

The infusion group is provided with a three-way valve called coffee valve.

It's a solenoid valve that is normally closed and opens when it receives a command to dispense coffee.

When this valve is closed, the liquid remaining in the group is pushed by pressure towards the third outlet of valve, that is connected to the exhaust manifold.

When this occurs, the water under pressure in the group, that cannot pass through the coffee cake, is pushed towards the third outlet of the valve, thereby drying the cake.

TYPICAL PROBLEMS

If there are problems connected to the coffee cake being completely soaked, three hypotheses can be evaluated:

- 1 The third outlet of the valve is obstructed, therefore the final section is less than it should be.
- 2 Shower and pavilion are blocked because of poor machine cleaning.
- 3 The group always drips, therefore soaks the cake.

4.7.1 REDUCING OF THE COFFEE BOILER INNER PRESSURE

Before to proceed with some operations, if the machine is hot, it is suggestable to reduce the inner pressure of the coffee boiler, to avoid spurts of hot water.

Proceed following the **EMPTY BOILER** procedure in Chapter 9.

It is enough to follow the procedure just for 10 seconds to reduce the coffee boiler inner pressure.

4.7.2 REMOVAL OF THE COFFEE VALVE

To replace the coffee valve, if the machine is hot, it is suggestible to reduce the inner pressure of the coffee boiler, as explained in the previous paragraph.

Then it is necessary to:

- 1 Turn the machine OFF.



- 2 Remove the side panels, the drip tray, the lower front panel and the group cover, as explained in Chapter 3.

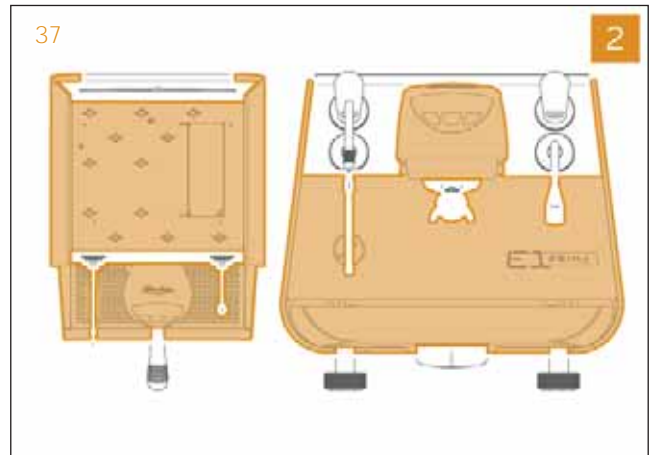

- 3 Utilizing plier, remove the clip keeping the Teflon pipe of the third outlet.



- 4 Disconnect the Teflon pipe of the third outlet.

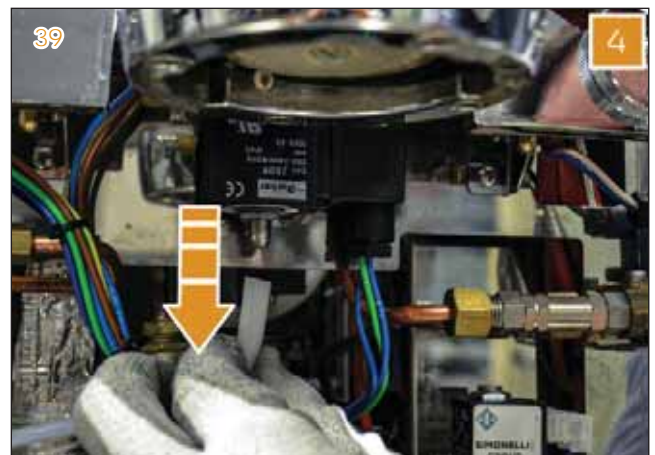

- 5 Utilizing a 14 mm wrench, unscrew the fixing nut of the coil.

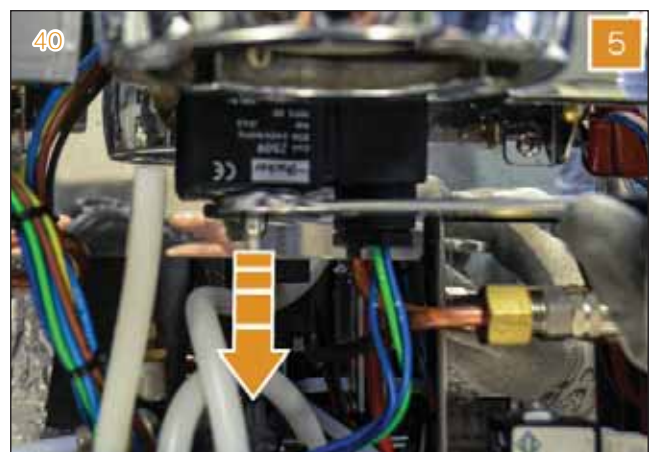

- 6 Utilizing a Philips screwdriver, remove the head screw.



- 7 Place a cloth or absorbent paper underneath the valve and, utilising a 3 mm Allen key, remove the two screws that fix the body to the group.



- 8 Remove the body of the valve. Check the contact points that often can be full of limescale. Clean utilising an adequately pointed tool.



- 9 Utilizing a vise and a 24 mm wrench, unscrew the valve base and check for the presence of limescale or oily residues.

These residues could obstruct the free circulation of the water to the third outlet, thereby by favouring stagnation of the water in the filter holder.

NOTE

In case of oily residues, properly instruct the staff using the machine to perform a regular, deep cleaning with suitable detergents.



05 STEAM BOILER



■ Replace every 12 months



INDEX

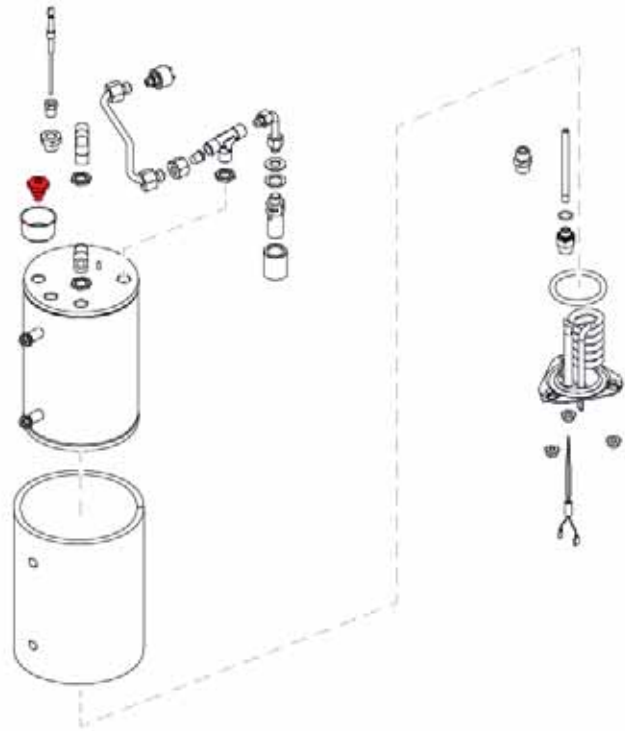

05

05	STEAM BOILER	59
5.1	REDUCING STEAM BOILER PRESSURE	61
5.2	EMPTYING THE STEAM BOILER	61
5.3	REMOVAL OF THE STEAM BOILER	62
5.4	HEATING ELEMENT	66
5.4.1	TEST THE HEATING ELEMENT	66
5.4.2	REMOVE THE HEATING ELEMENT	67
5.5	THE SAFETY THERMO-FUSE	68
5.6	THE LEVEL PROBE	70
5.7	ANTI-SUCTION VALVE	71
5.8	SAFETY VALVE	72



The **EI PRIMA** is provided by a Stainless-Steel boiler of 1,5 l. It is covered by thermal insulation to prevent heat dispersion and it is equipped with the following parts.

On the top:

- A An anti-suction valve, to ensure that air enters the boiler during the machine cooling phase.
- B A level probe, to maintain a constant water level inside the boiler.
- C A pressure sensor connection fitting, to read the boiler pressure.
- D A 3 bar safety valve connection fitting.
- E A steam solenoid valve connection fitting.

On the bottom:

- F A water inlet connection fitting.
- G A hot water solenoid valve connection fitting.
- H A 1600 W heating element.
- I A 184°C safety thermo-fuse.
- J A ground connection.

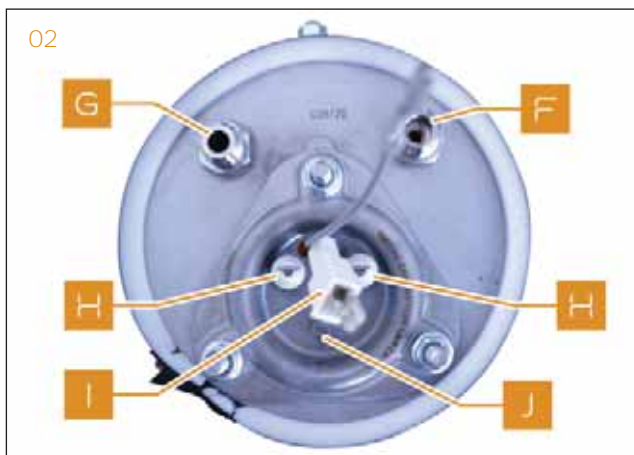
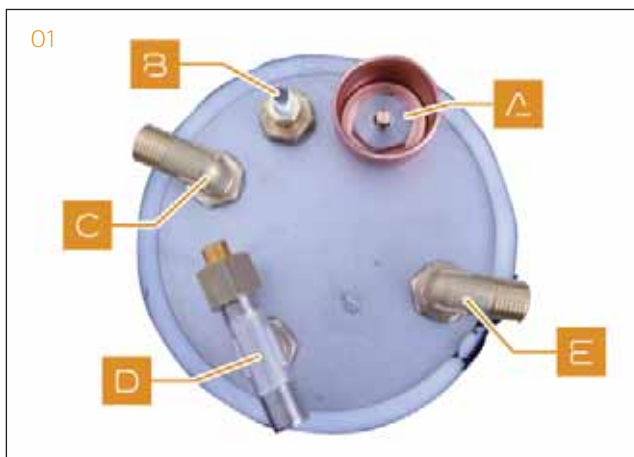

Except where specified, before proceeding with the following operations, make sure that the machine is turned OFF and unplugged from the mains. Discharge any residual pressure present in the steam boiler.



If the machine was turned OFF recently, protect yourself with thermal insulation gloves.



5.1 REDUCING STEAM BOILER PRESSURE

Before to work on steam boiler and relative parts, it is mandatory to reduce its inner pressure.

The **E1 PRIMA**, compared to the other traditional machines, does not have manual steam lever, but electronic one.

Hence, to reduce steam boiler pressure it is needed to run a software procedure, that is called **EMPTY BOILER** procedure and it is explained in Chapter 9.

Keep the procedure working till no more steam is coming out from the boiler and then switch the machine OFF.



5.2 EMPTYING THE STEAM BOILER

If the previous paragraph with the **EMPTY BOILER** procedure has been followed, most of the contained water has been already extracted. In this way, when the boiler will be removed, only a small quantity of water will pour out.

In the case it is preferred to extract the total amount of the water, or the **EMPTY BOILER** procedure has not been followed since the machine was cold, it is suggestable to extract the water by accessing the boiler from the top (e.g. by removing the anti-suction valve) and by using a long syringe.



5.3 REMOVAL OF THE STEAM BOILER

To remove the steam boiler, proceed as follow:

1 Remove the cup holder surface and the left side panel, as described in Chapter 3.



05 2 Disconnect the level probe.

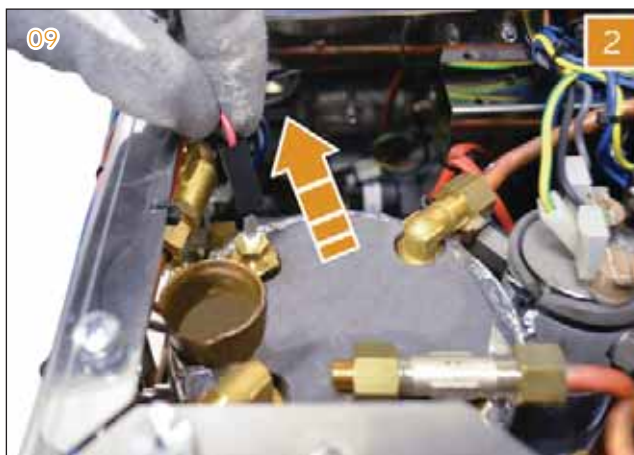

3 Utilizing a 17 mm wrench, disconnect the outlet steam pipe.



4 Utilizing a 17 mm wrench, disconnect the safety valve pipe.

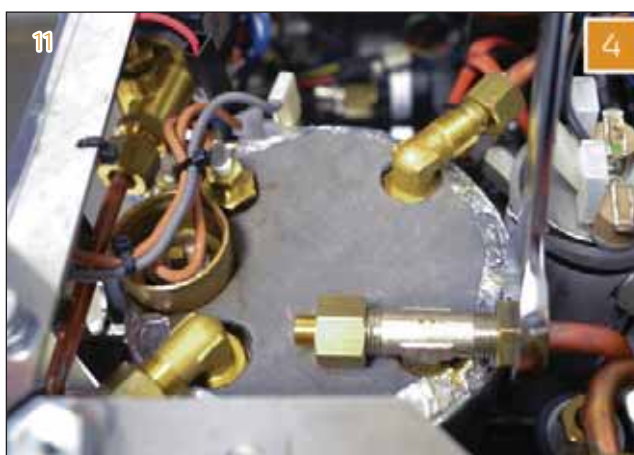

5 Remove the safety valve.



6 Utilizing a 17 mm wrench, disconnect the pressure sensor pipe.



7 Utilizing a 17 mm wrench, disconnect the hot water pipe.



8 Utilizing a 17 mm wrench, disconnect the inlet pipe.

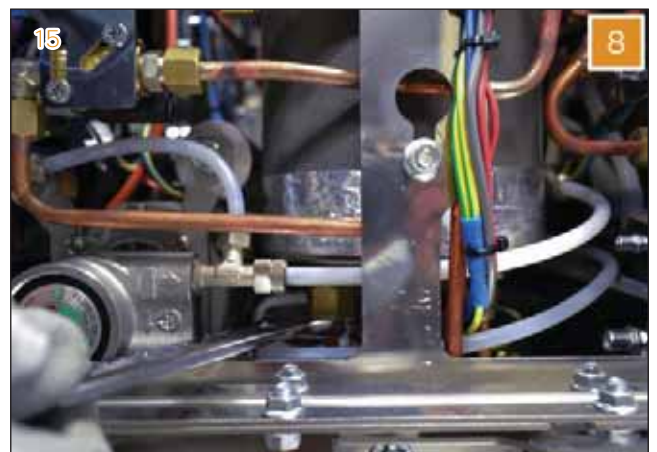

9 Rotate the machine on the right side, being careful to not damage it.



05
10 Utilizing a Philips screwdriver, remove the two screws that keep the base cover.



11 Disconnect the five electrical cables, corresponding to: thermal fuse, heating element and mass.



12 Rotate the machine again in standard position.



13 Utilizing a 10 mm wrench, remove the two nuts.

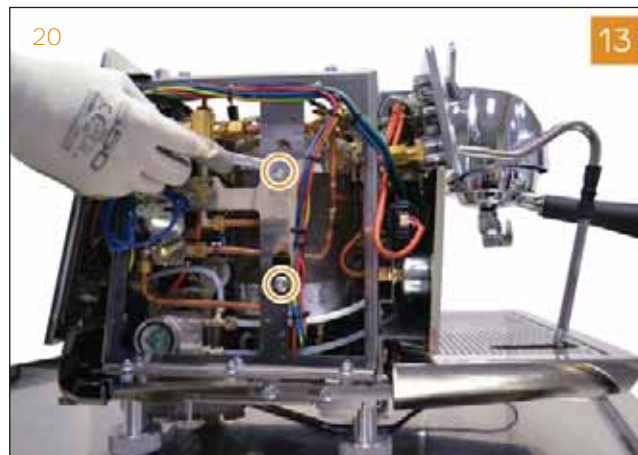

14 Remove the steam boiler, lifting it upwards and turning it clockwise.

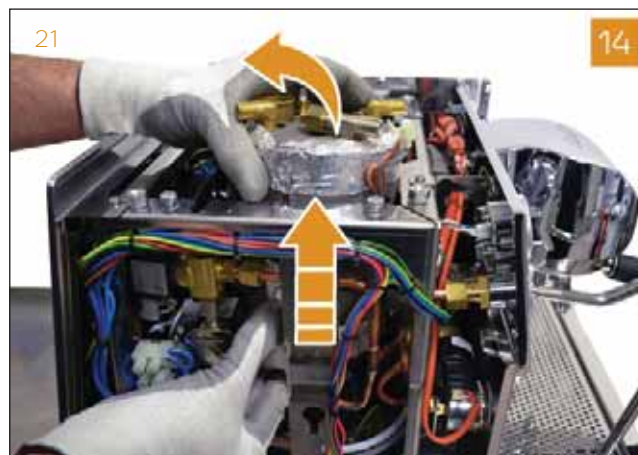

05

5.4 HEATING ELEMENT

The 1600 W heating element is removable and it is accessible from the bottom of the machine.

5.4.1 TEST THE HEATING ELEMENT

To test the heating element, proceed as it follows:

- 1 Rotate the machine on the right side, being careful to not damage it.
- 2 Utilizing a Philips screwdriver, remove the two screws that keep the base cover.
- 3 Disconnect the electrical resistance cables. For easier access, it is useful to remove the safety thermo-fuse too.
- 4 Utilizing a tester, check the heating element (value $34 \pm 2 \text{ Ohm}$).

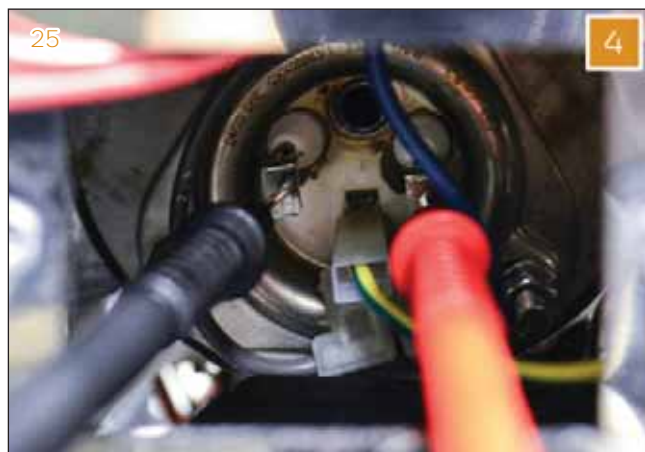
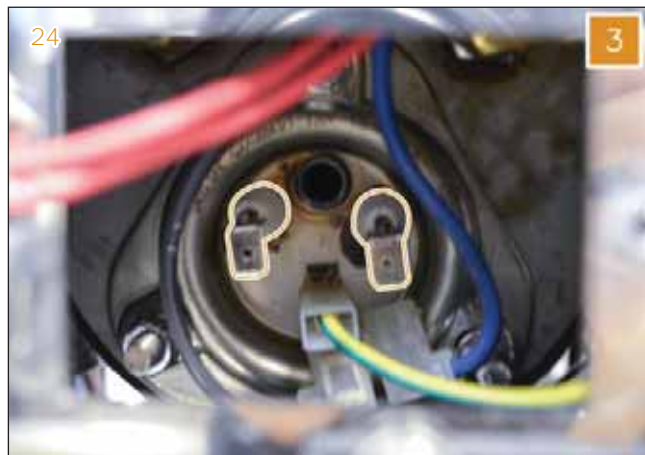

5.4.2 REMOVE THE HEATING ELEMENT

To remove the heating element, proceed as it follows:

- 1 Remove the steam boiler, as described in paragraph 5.3.
- 2 Remove the safety thermo-fuse.
- 3 Utilizing a 10 mm wrench, remove the three nuts.
- 4 With the help of a screwdriver, remove the heating element.

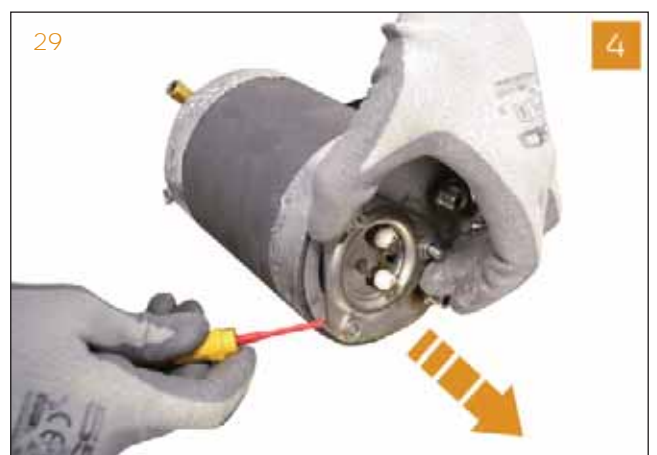
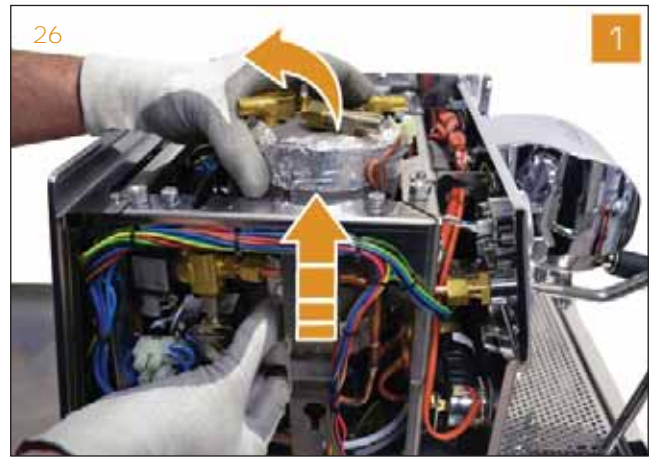

NOTE

Each time you replace the heating element is also necessary to change the viton O-ring that isolates it from the boiler because it is a part subject to wear, therefore the component must be ordered together with the heating element.

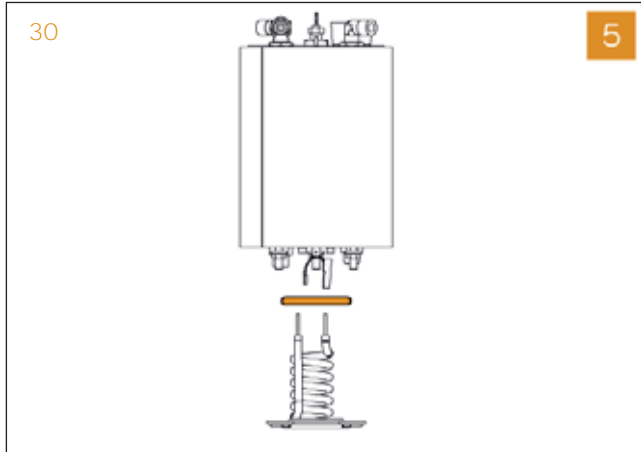

05

5.5 THE SAFETY THERMO-FUSE

The safety thermo-fuse is connected in series with the Power IN of the control unit and of the transformer, and opens the electrical circuit once the temperature limit of 184°C in the steam boiler has been exceeded. If the machine does not turn ON, remove the safety thermo-fuse and check its continuity. Proceed as it follows:

- 1 Rotate the machine on the right side, being careful to not damage it.
- 2 Utilizing a Philips screwdriver, remove the two screws that keep the base cover.
- 3 Extract the safety thermo-fuse.



4 Disconnect the safety thermo-fuse.



5 Utilizing a tester, check the continuity of the safety thermo-fuse.

If there is not continuity, change the safety thermo-fuse.



05

5.6 THE LEVEL PROBE

The water inside the steam boiler is maintained at a constant level through the use of a level probe inserted inside the boiler. This probe is connected to the electronic control unit that continuously polls the probe.

Being always exposed to high temperatures and steam/water it is subject to encrustations which can inhibit operations.

05

WHEN TO INTERVENE

- In case it is verified that there are no problems upstream from the probe you can easily access the component and perform careful cleaning with abrasive or descaling agents.
- Make sure that the Teflon coating of the probe is not damaged. If it is, there would be a loss of steam and electric insulation and the probe should be replaced.

TO REMOVE THE PROBE

- 1 Simply disconnect the red wire.
- 2 Utilizing a 17 mm cup hex wrench, unscrew the probe from its housing.

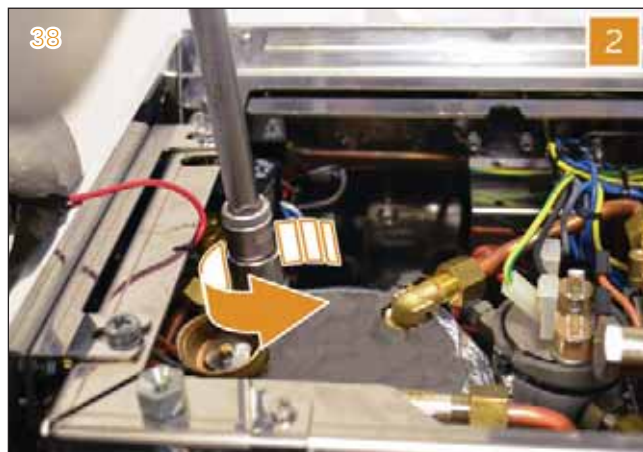
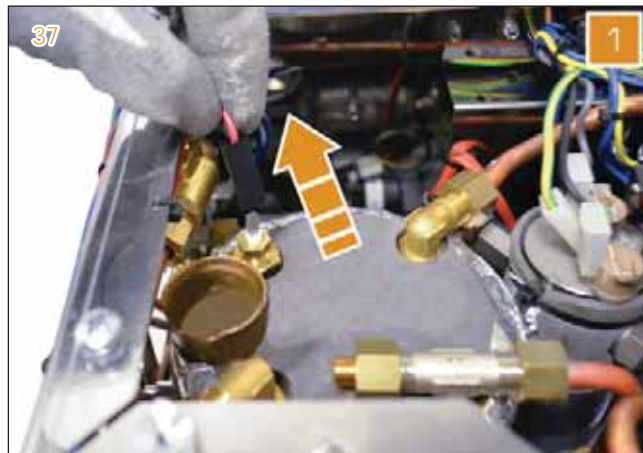

5.7 ANTI-SUCTION VALVE

The anti-suction valve ensures that air enters the heater during the machine cooling phase. In this way the reduction of water volume due to cooling does not create decompressions that may give rise to drawbacks such as the suction of milk through the steam wand.

WHEN TO REPLACE

You can assume that there are problems with the anti-suction valve when:

- There is a strong smell of rot when making steam or water is extracted from the heater.
- The water leaving the heater is dirty.

In these cases the valve is closed and is locked in this condition.

If the valve blocked open because of limestone the signs would be:

- A continuous slight whistling sound coming from the valve.
- Condensation drops near the valve.

NOTE

We suggest that the valve (A) be replaced annually to ensure proper function and excellent sealing wand.



WARNING

Operation to be carried out with the pressure in the boiler at zero (0 bar).

HOW TO REPLACE

Using a 19 mm cup hex wrench unscrew the valve from its housing.

When inserting the new one, coat the threads with Teflon tape or with a few drops of Loctite.

39



05

40

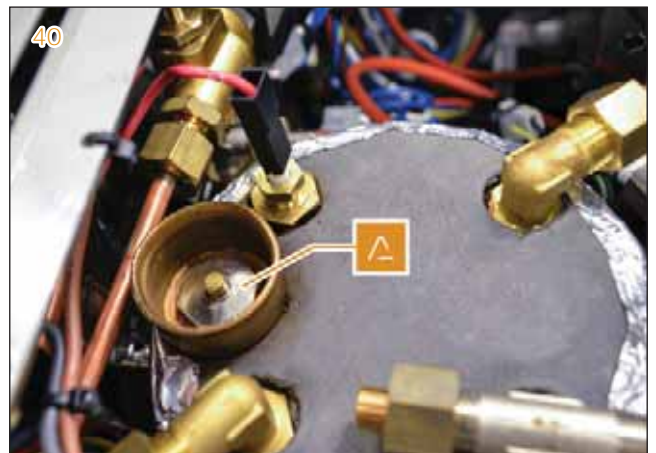

41

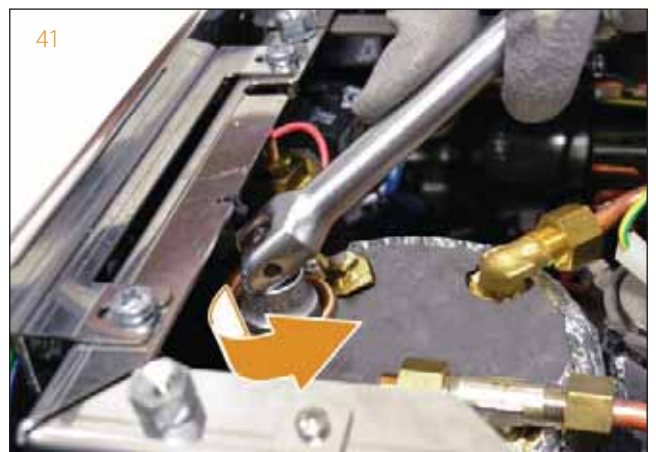

5.8 SAFETY VALVE

The steam safety valve is made to open at the pressure of 3 bar.

WHEN TO REPLACE

For safety reasons each time the valve comes into operation it should be replaced to ensure perfect operation.

So if the heater floods or there is excess steam it is necessary to secure the machine by replacing the entire valve.

05

HOW TO REPLACE

To replace the safety valve proceed as it follows.

1 Utilizing a 17 mm wrench, remove the safety valve pipe from the boiler.



2 Utilizing a 17 mm wrench and a 14 mm cup hex wrench, open the safety valve.



06

COFFEE BOILER



■ Replace every 12 months



INDEX

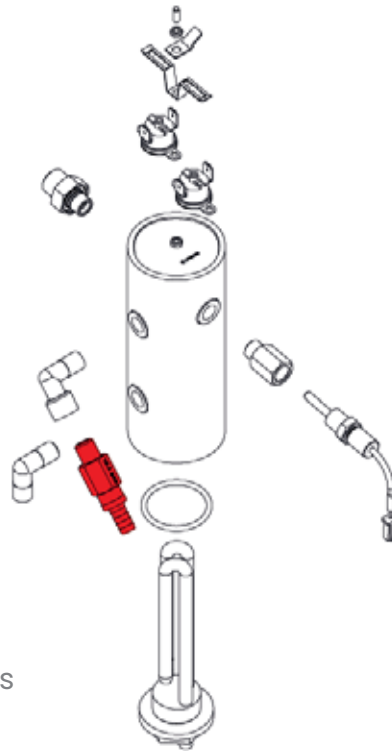

06	COFFEE BOILER	73
6.1	REMOVAL OF THE COFFEE BOILER	75
6.2	HEATING ELEMENT	79
6.2.1	CHECK AND REMOVAL OF THE HEATING ELEMENT	79
6.3	TEMPERATURE PROBE	81
6.3.1	REMOVAL OF THE TEMPERATURE PROBE	82
6.4	HIGH-LIMIT THERMOSTATS	84
6.5	EXPANSION VALVE	84
6.5.1	REMOVAL OF THE EXPANSION VALVE	84
6.6	PROCEDURE FOR AUTOMATICALLY FILLING THE COFFEE BOILER	86



EI PRIMA provides for the group a Stainless-Steel coffee boiler of 0.14 litre.

The coffee boiler is part of the **NEO** (New Engine Optimization), that guarantees high performance while reducing the energy consumption of the machine.

It is covered by thermal insulation to prevent heat dispersion.

Each coffee boiler is equipped with:

- A A heating element of 600 W.
- B A temperature probe.
- C An expansion valve at 16,5 bar.
- D Two 135°C high-limit thermostats connected in series with the heating element.
- E A ground connection.
- F A water inlet connection fitting.
- G A water outlet connection fitting.

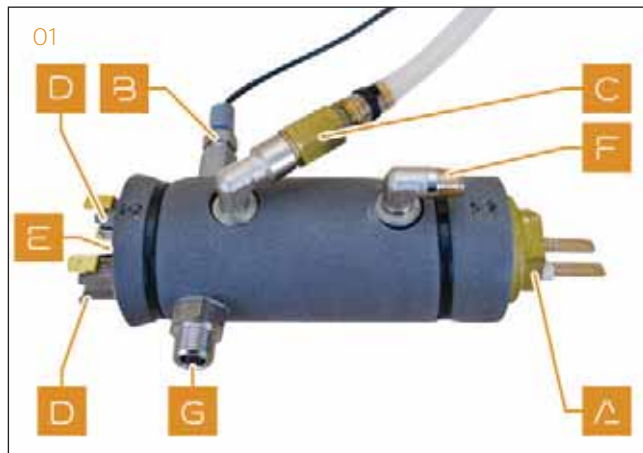

DANGER

Before proceeding with the operations described in this chapter make sure that the machine is turned OFF.



WARNING

If the machine was turned OFF recently, protect yourself with thermal insulation gloves.



6.1 REMOVAL OF THE COFFEE BOILER



WARNING

The coffee boiler contains just 0.14 litre of water, therefore it is not necessary to empty it when it is needed to remove it or its components. If the machine is hot, it is suggestible to reduce the inner pressure of the coffee boiler, as explained in paragraph 4.7.1.

Moreover, it is always a good idea to place a cloth or absorbent paper underneath the coffee boiler pipes to avoid potential electrical damages.

To remove the coffee boiler, proceed as it follows:

- 1 Remove the cup holder surface, the right side panel and the water tank, as described in chapter 3.
- 2 Disconnect the cables on the top of the coffee boiler.
- 3 Disconnect the temperature probe from the control unit.

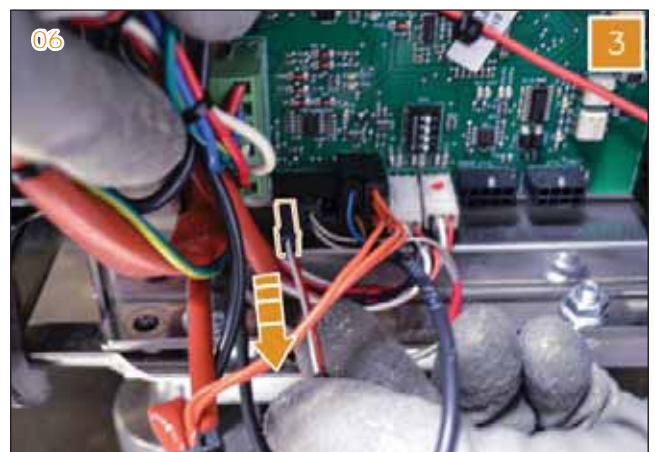

4 Remove the 4 screws that hold the control unit support.

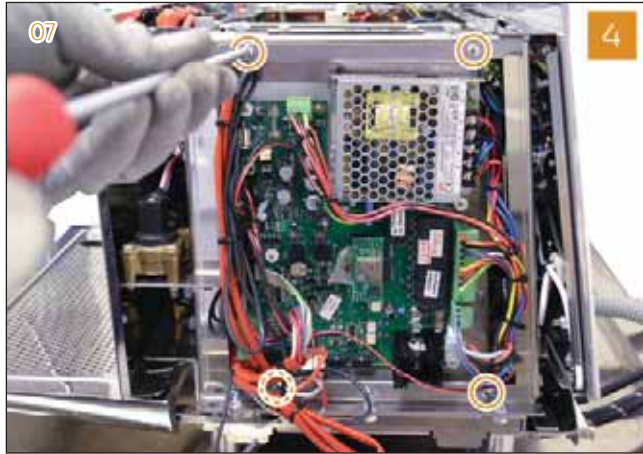

5 Remove the control unit support and, if preferred, disconnect the cables to simplify the operations.



6 Extract the temperature probe cable and, if necessary, cut the clamps.



7 Utilizing a 12 mm and 13 mm wrenches, unscrew and remove the temperature probe.



8 Remove the 4 screws of the water tank support.

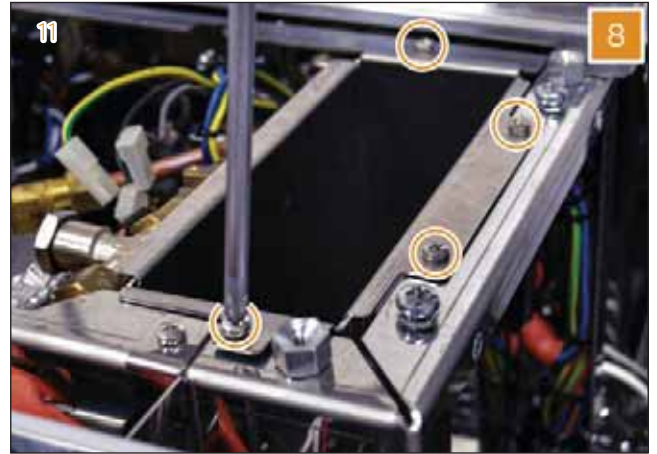

9 Extract the water tank support and place it on the machine.



10 Disconnect the two heating element cables from the bottom of the coffee boiler.



11 Utilizing a 13 mm wrench by entering from the right side of the machine, and keeping the coffee boiler with the other hand, unscrew the inlet coffee boiler pipe.



12 Reposition the water tank support.

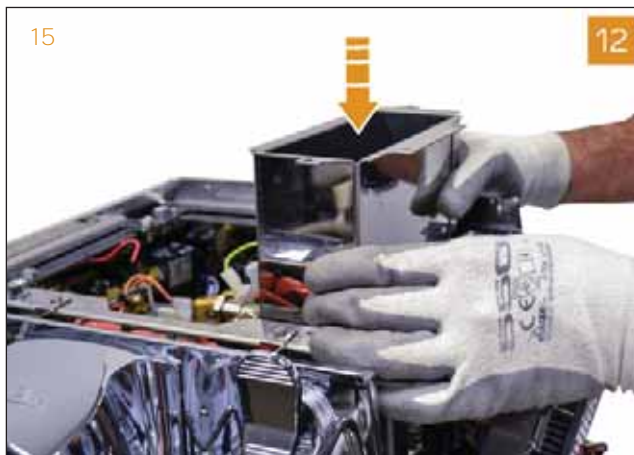

13 Utilizing a 17 mm wrench, remove the safety valve of the steam boiler.

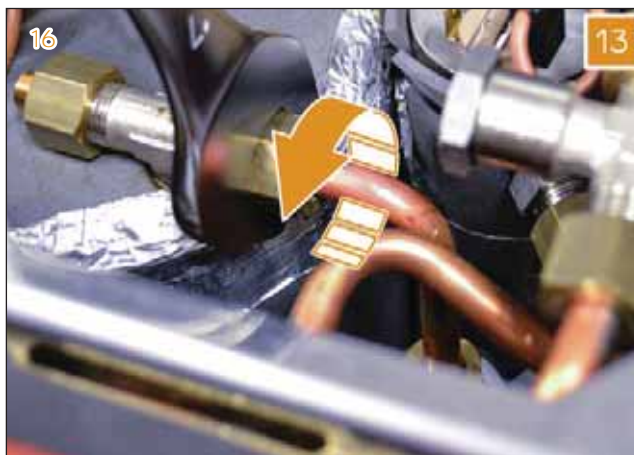

14 Utilizing a 17 mm wrench and keeping the coffee boiler, unscrew the outlet pipe to the group.



15 Cut the clamp of the expansion valve and extract the pipe.



6.2 HEATING ELEMENT

The **NEO** technology manages temperatures of the "infusion group and coffee boiler" system, to give a proper extraction water temperature, in accord with what has been set in the programming as **MYCOFFEE temperature**.

When the heating element of the coffee boiler needs to be powered ON, the control unit activates it.

To know when it is activated, it is possible to monitor LED placed on the control unit.

The LED is labelled "**CH**".

NOTE

For further information about the control unit, refer to Chapter 8.

6.2.1 CHECK AND REMOVAL OF THE HEATING ELEMENT

To access the heating element, it is necessary to remove the coffee boiler as described in the previous paragraph.

To detect if the heating element is damaged, it is possible to verify its value with a tester.

Typical value is 90 ± 7 Ohm.

If the breaker of the electric panel in the bar interrupts the power, the cause could be the heating element in short circuit.

Use a tester to verify continuity of the heating element with the ground: continuity would mean the heating element is damaged.

If the power does not interrupt but the water of the coffee boiler is cold, the cause could be the heating element in open loop.

Use a tester to verify continuity of the heating element itself: continuity would mean the heating element is fine.

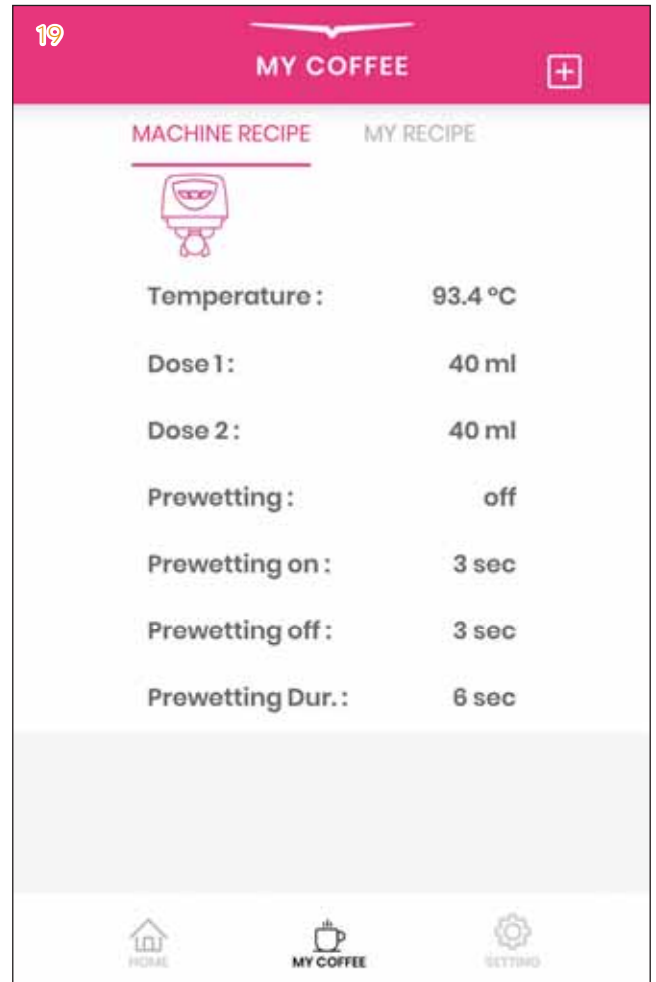

To remove the heating element, it is necessary to:

1 Secure the coffee boiler to a vice.



2 Using a 26 mm wrench, remove the heating element.



06

NOTE

When replacing the heating element, it is mandatory to utilize a new O-ring.



WARNING

After replacing the coffee boiler, proceed with restoring water inside the coffee boiler as described in paragraph 6.6.

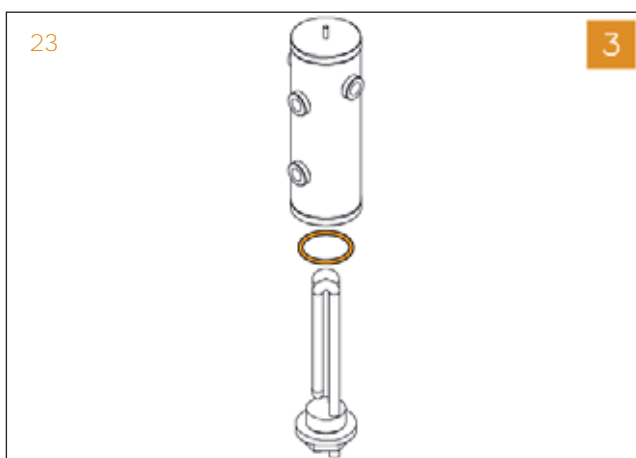

6.3 TEMPERATURE PROBE

The temperature probe of the coffee boiler permits to the control unit to know the current temperature of the coffee boiler.

Typical values of the temperature probe are approximately 40 kOhm at about 25°C (room temperature) and 5 kOhm at about 90°C.

E1 PRIMA software can detect possible malfunctions of the temperature probe.

If alarms **A4** or **A5** (probes alarms) are shown on the group display, this temperature probe could be involved.

Possible solutions are:

- 1 Check the probe cable and its connection to the control unit
- 2 Replace the probe.

NOTE

For further information on the temperature probe alarms, refer to Chapter 10.

If the temperature displayed in the **Victoria Arduino E1** App is extremely high or quite unstable despite the smooth operations, remove and replace the probe with a new one.

Since the coffee boiler is always, full of high temperature water, common limestone problems do not excessively affect the temperature probe. In fact, it is unlikely that the limestone will inhibit the operation on the probe, but more likely it will slow its capacity: a probe covered with limestone becomes less sensitive to temperature changes. In cases like this in which there are no significant changes that place the coffee boiler under stress, the probe must be removed and controlled for the presence of limestone.

24

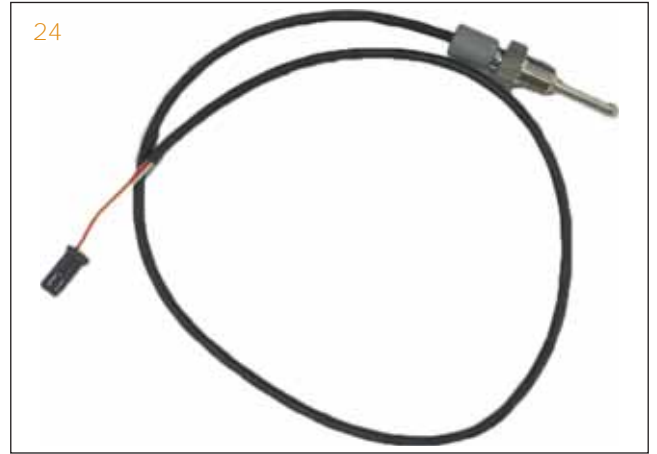

25

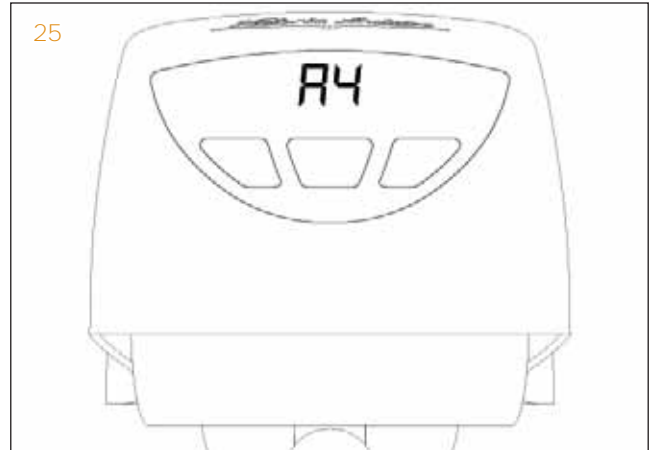

06

6.3.1 REMOVAL OF THE TEMPERATURE PROBE



WARNING

If the machine is hot, reduce the inner pressure of the coffee boiler, as explained in paragraph 4.7.1.

To remove the temperature probe, proceed as it follows:

1 Remove the cup holder surface and the right side panel, as described in chapter 3.

2 Disconnect the temperature probe from the control unit.

3 Remove the 4 screws that hold the control unit support.

26



27

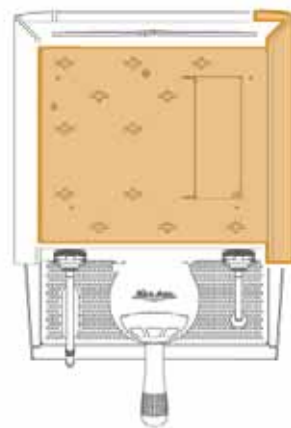

28

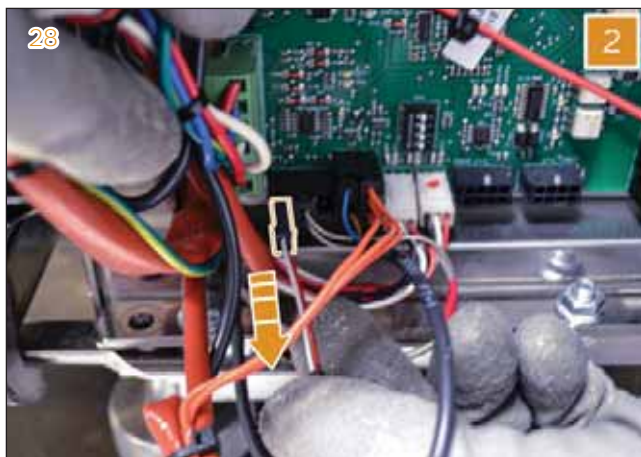

29

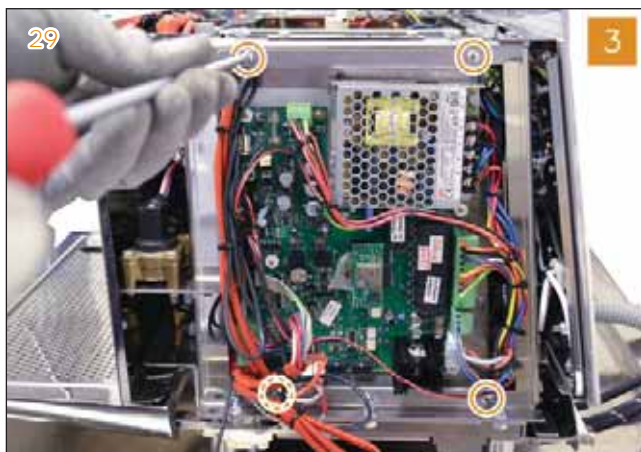

- 4 Remove the control unit support and, if preferred, disconnect the cables to simplify the operations.

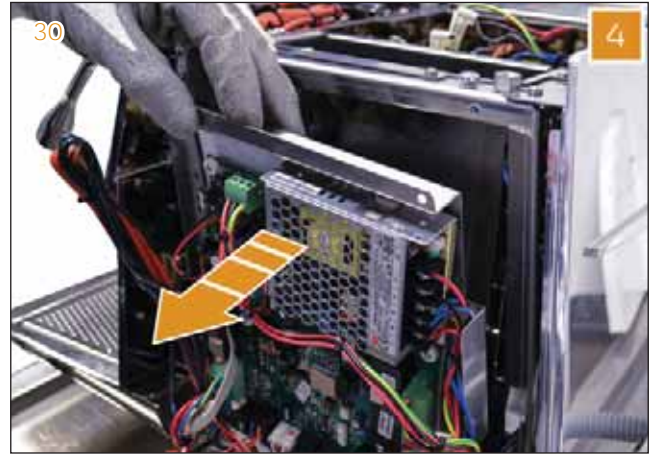

- 5 Extract the temperature probe cable and, if necessary, cut the clamps.



- 6 Utilizing a 12 mm and 13 mm wrenches, remove the temperature probe.



Remove calcification with appropriate products.

NOTE

When replacing the temperature probe, wrap its threading with Teflon tape or use liquid Loctite to prevent leakage.



6.4 HIGH-LIMIT THERMOSTATS

The high-limit thermostats are connected in series with the heating element and open the electrical circuit once the temperature limit of 135°C in the coffee boiler has been exceeded.

If the heating element does not turn ON, check the continuity of the high-limit thermostats.

If there is not continuity, rearm the high-limit thermostats pushing into the hole by a small screwdriver.



6.5 EXPANSION VALVE

The expansion valve releases water once the pressure limit of 16,5 bar in the coffee boiler has been exceeded.

If, when the machine was in stand-by, the first coffee dose is lower than the next, a reason could be the expansion valve damaged and opening before 16.5 bar.

6.5.1 REMOVAL OF THE EXPANSION VALVE



WARNING

If the machine is hot, reduce the inner pressure of the coffee boiler, as explained in paragraph 4.7.1.

To remove the expansion valve, proceed as it follows:

- 1 Remove the coffee boiler, as described in paragraph 6.1.



- Utilizing a 14 mm wrench and a plier, remove the valve.

NOTE

When replacing the expansion valve, wrap its threading with Teflon tape or use liquid Loctite to prevent leakage.

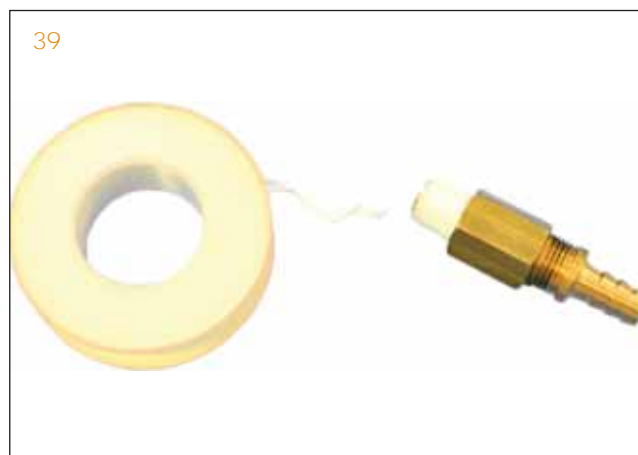

6.6 PROCEDURE FOR AUTOMATICALLY FILLING THE COFFEE BOILER

Once the various parts of the coffee boiler, or the boiler itself, have been replaced, it is necessary to carefully fill it to prevent it from starting to heat in the absence of water.

If this were to happen the high-limit thermostat would open the electrical circuit to protect the heating element.

If before the operations the **EMPTY BOILER** procedure has been executed, when the machine will be switched ON, it will automatically enter the **FILLING** procedure.

If the **EMPTY BOILER** procedure has not been executed, to execute the filling of the coffee boiler it is needed to enter the **FILLING** procedure, as described in chapter 9.



WARNING

If the boiler is not completely filled with water, this could damage the heating element.

40

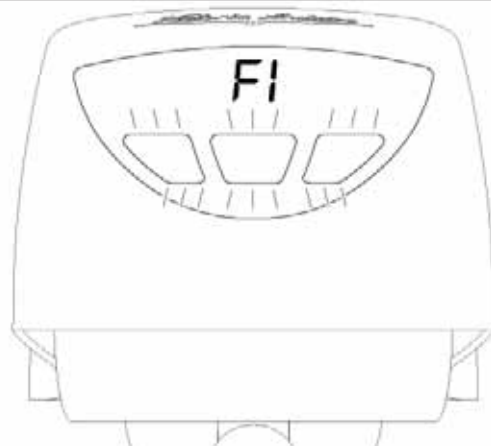

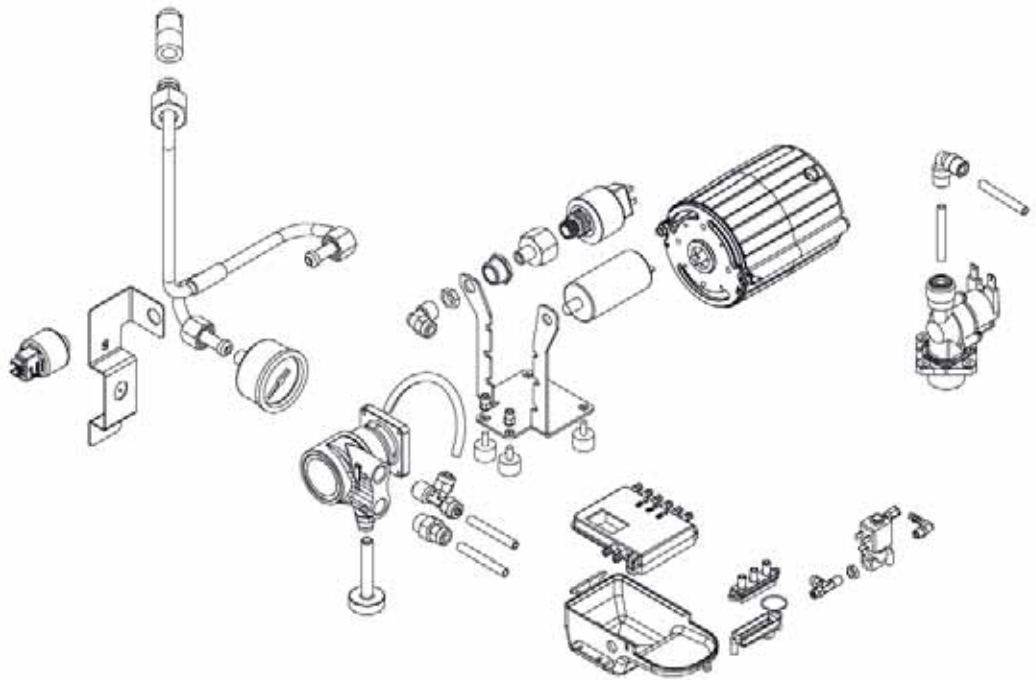

INDEX

07	HYDRAULIC CIRCUIT	87
7.1	EXHAUST MANIFOLD AND DRAIN BOX	88
7.2	TANK	89
7.3	TANK VALVE AND WATER STOP VALVE	89
7.3.1	REMOVAL OF THE TANK VALVE	89
7.3.2	REMOVAL OF THE WATER STOP VALVE	91
7.4	THE PUMPING ELEMENT	93
7.4.1	REMOVAL OF THE PUMP	93
7.4.2	REMOVAL OF THE CONDENSER	97
7.4.3	REMOVAL OF THE MOTOR	97
7.5	REMOVAL OF THE AUTO-FILL VALVE	98
7.6	FLOWMETER AND NOT RETURN VALVE	100
7.6.1	REMOVAL OF THE FLOWMETER	101
7.6.2	REMOVAL OF THE PRE INFUSION RESTRICTOR	104
7.6.3	REMOVAL OF THE NOT-RETURN VALVE	104
7.7	HOT AND COLD WATER VALVE	105
7.7.1	REMOVAL OF THE HOT WATER VALVE	106
7.7.2	REMOVAL OF THE COLD WATER VALVE	109
7.8	STEAM VALVE	110
7.8.1	REMOVAL OF THE STEAM VALVE	110
7.9	STEAM, HOT WATER AND EASYCREAM (OPTIONAL) WANDS	114
7.9.1	DISMANTLING THE WAND	114
7.10	EASYCREAM (OPTIONAL)	118
7.11	REMOVAL OF THE PRESSURE GAUGE	121

The hydraulic circuit of the **EI PRIMA** follows a new technology: **NEO** (New Engine Optimization).

The **NEO** engine uses an instant heating system allowing only the necessary amount of water for the extraction.

To be heated, thus using less amount of water and boiler optimization. Productivity and performance remain constant, while energy efficiency increases.



DANGER

Before proceeding with the operations described in this chapter make sure that the machine is turned OFF and unplugged from the mains.

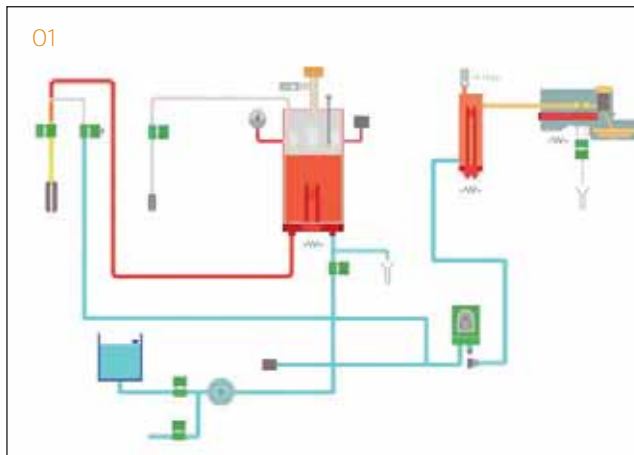

7.1 EXHAUST MANIFOLD AND DRAIN BOX

The exhaust manifold (**A**) is placed on the front of the machine.

It collects the exhaust pipes of: the coffee boiler's expansion valve, the coffee valve and the steam valve.

When the machine is closed, the exhaust manifold drains into the drip tray.

Below and behind the exhaust manifold there is the drain box (**B**).

It collects the waste water of the drip tray, only when the drip tray has been drilled.

This occurs when it is preferred to use a direct waste water system: in this case, the drain box is also connected to the waste water pipe.

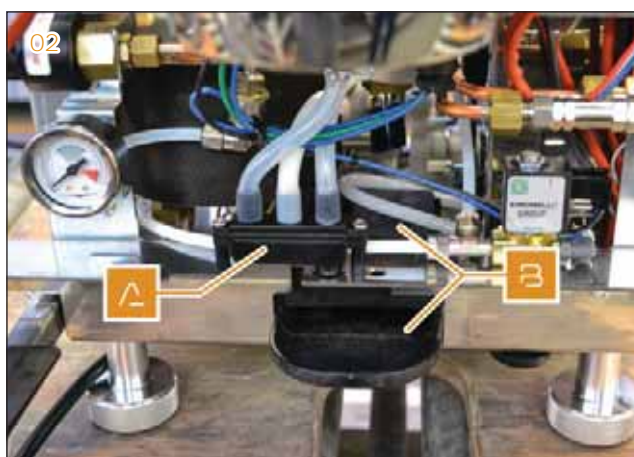

7.2 TANK

The tank is easily removable by hand and it is reachable by opening the tank cover on the cup holder surface. It can contain up to 1.5 lt of water. It does not contain any float, since a capacitive sensor, placed on the external surface of the tank container, can feel the water presence inside the tank. To check if the tank is correctly working, push the small valve on its bottom.

7.3 TANK VALVE AND WATER STOP VALVE

The **EI PRIMA** is always provided with the tank valve and water stop valve. The tank valve is placed on the front of the machine under the flowmeter and its inlet is connected with the tank; the water stop valve is placed on the back of the machine and its inlet is connected with the water mains.

Outputs of both valves are connected to the pump.

When the machine requests water, the control unit opens only the correct valve, depending on the type of water supply set.

7.3.1 REMOVAL OF THE TANK VALVE

To remove the tank valve, proceed as it follows:

- 1 Remove the cup holder surface, the side panels, the drip tray, the lower front panel and the tank as described in Chapter 3.
- 2 Utilizing a 12 mm wrench, remove the two Teflon pipes of the T connection.

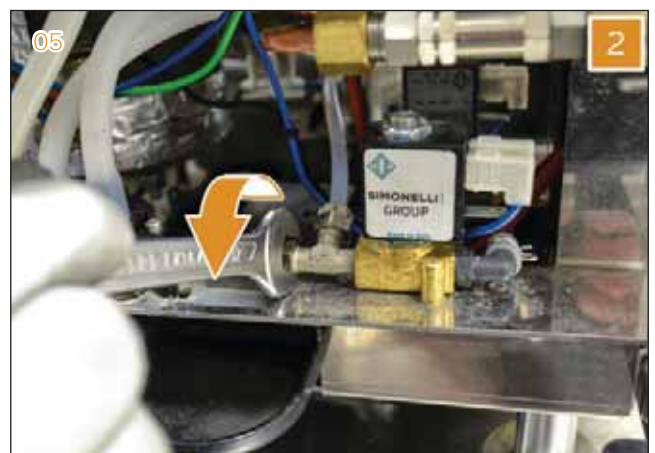

3 Disconnect the cables from the tank valve.

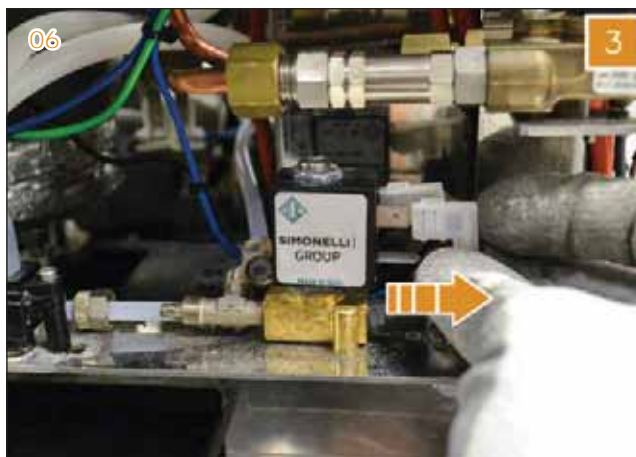

4 Utilizing a small screwdriver, unscrew the two screws that fix the valve to the frame.

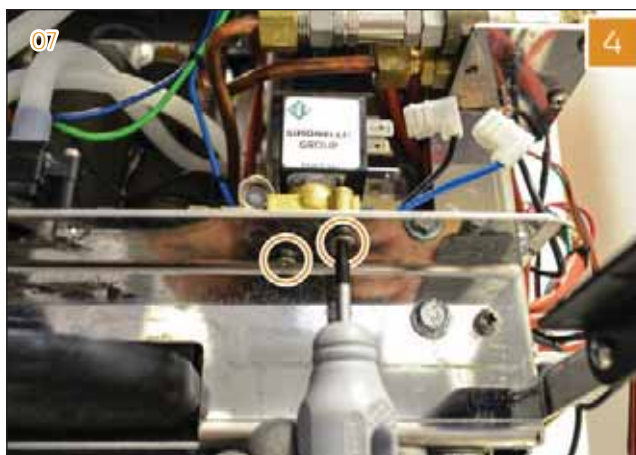

5 Utilizing a plier, remove the clip and the Teflon pipe of the third outlet.

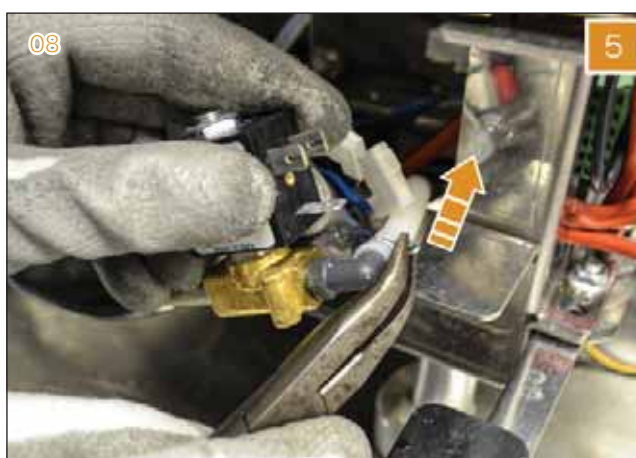

6 Utilizing a vise and a 14 mm wrench, unscrew the nut and remove the coil of the valve.



7 If the inspection of the valve is needed, follow the same procedure described in paragraph 7.8.1 for the steam valve, by utilizing a vise and a 14 mm wrench.



7.3.2 REMOVAL OF THE WATER STOP VALVE

To remove the water stop valve, proceed as it follows:

1 Close the water mains.

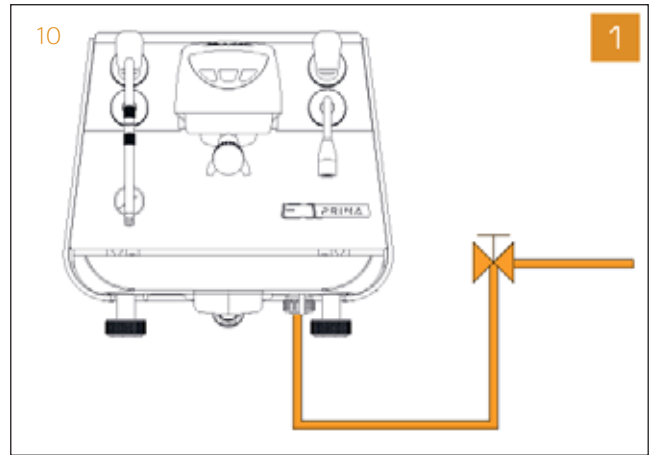

2 Remove the cup holder surface, the side panels, the rear panel and the rear lower panel as described in Chapter 3.

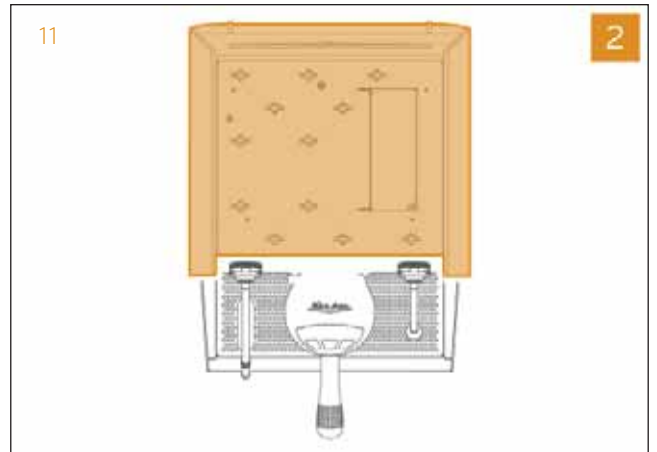

3 Lift the machine from the back part and remove the inlet pipe.



4 Utilizing a Philips screwdriver, unscrew the two screws that fix the water stop valve to the frame.



5 Remove the electrical cables.



6 Utilizing a flat screwdriver, push the black ring and extract the pipe.



7 Extract the valve.



07



7.4 THE PUMPING ELEMENT

The pump is located on the left side of the machine. The duration of the pump depends on the amount of daily work and the quality of the water. The machine pressure set by the factory is ideal for the extraction of the coffee: 9 bar.

WHEN TO REPLACE

- **It is noisy:** if the impurities enter inside the pump, the blades of the impeller may block, therefore making it impossible to load water.
- **Pressure not adjustable:** with time the impeller blades can wear out, therefore if it is not possible to adjust the pressure with the appropriate wheel it would be necessary.
- **Pressure fluctuation during dispensing:** the bypass or the impeller are damaged.

7.4.1 REMOVAL OF THE PUMP

To replace the pump it is necessary to remove the complete pump-motor assembly. Proceed as it follows:

- 1 Remove the cup holder surface, the side panels, the rear panel and the drip tray as described in Chapter 3.

- 2 Reassemble the right side panel.

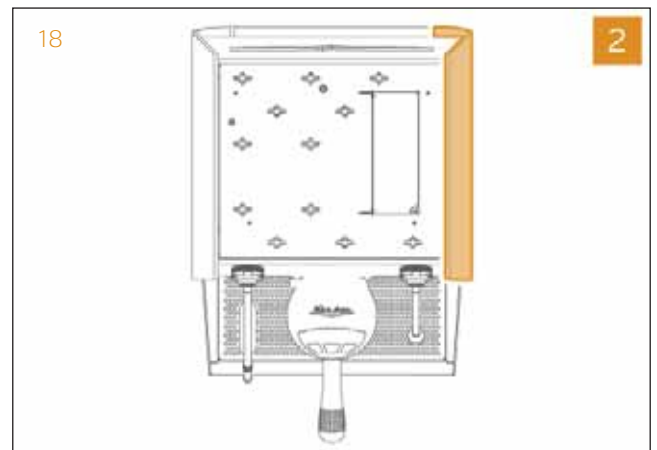

- 3 Rotate the machine on the right side, being careful to not damage it.



- 4 Completely unscrew and remove the pressure control wheel.



NOTE

Notice that the pressure control wheel contains a spring.

- 5 Utilizing a 7 mm wrench, remove the four nuts and washers that fix the pump-motor assembly to the frame.



- 6 Rotate the machine again in standard position.



- 7 Utilizing a 12 mm wrench, remove the inlet and outgoing Teflon pipes of the pump.



- 8 Utilizing a Philips screwdriver, remove the three screws that fix the static relay bracket.



- 9 Remove the static relay bracket.

NOTE

If it is necessary, disconnect some cables.

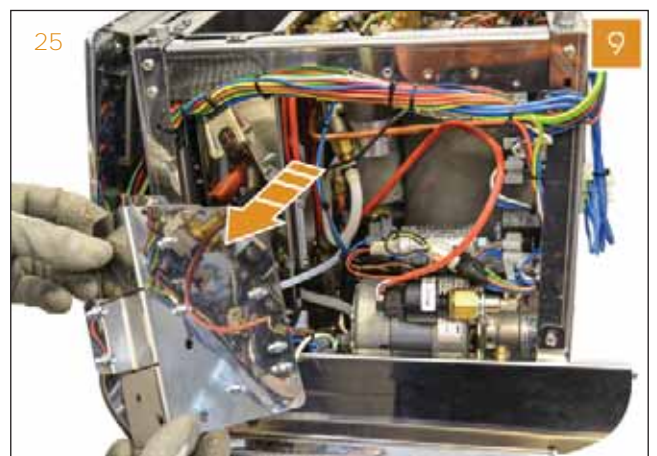

- 10 Remove the pump-motor assembly.

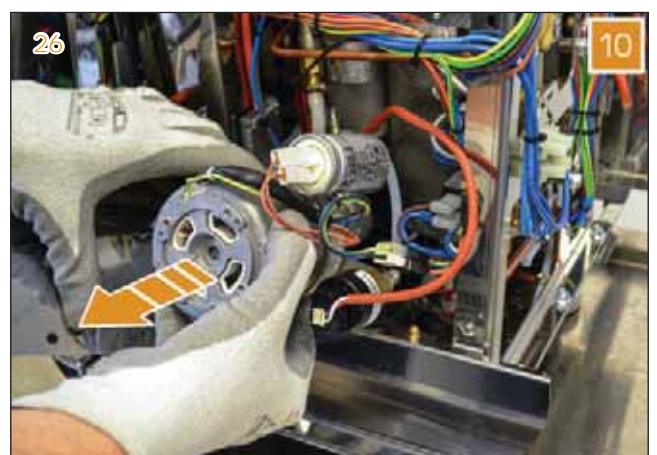

Once the pump-motor assembly has been removed, to replace the pump proceed as it follows:

11 Utilizing a 14 mm wrench, remove the inlet fitting of the pump.



12 Utilizing a 12 mm wrench, remove the Teflon pipe.



13 Utilizing a 9 mm wrench, remove the T outgoing fitting of the pump.



14 Utilizing a 2,5 mm Allen key, remove the four screws that fix the pump.



NOTE

When reassembling the inlet and outgoing fittings on the pump, it is advisable to use Loctite glue.

7.4.2 REMOVAL OF THE CONDENSER

Once the pump-motor assembly has been removed and the condenser needs to be replaced, proceed as it follows:

1 Disconnect the cables from the condenser.

2 Utilizing a 13 mm wrench, remove the condenser.



7.4.3 REMOVAL OF THE MOTOR

Once the pump-motor assembly and the pump have been removed and the motor needs to be replaced, proceed as it follows:

1 Utilizing a Philips screwdriver, remove the four screws that hold the motor.



7.5 REMOVAL OF THE AUTO-FILL VALVE

The auto-fill valve is positioned on the left side of the machine, over the pumps. Its operation regulates the amount of water that flows inside the heater during all phases of machine operation. The control unit continuously interrogates the level sensor and opens the valve if the level of water in the boiler is not sufficient to cover the heating element.

To remove the auto-fill valve, proceed as it follows:

- 1 Remove the cup holder surface and the left side panel, as described in Chapter 3.

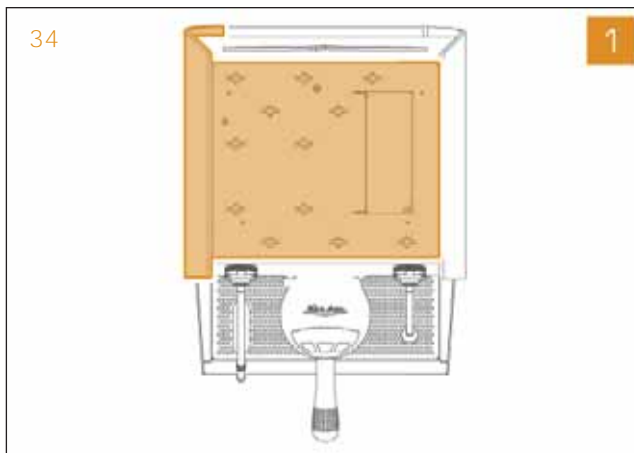

- 2 Empty the boiler as described in paragraph 5.2.



- 3 Utilizing a 13 mm wrench, disconnect the outgoing pipe from the auto-fill valve.

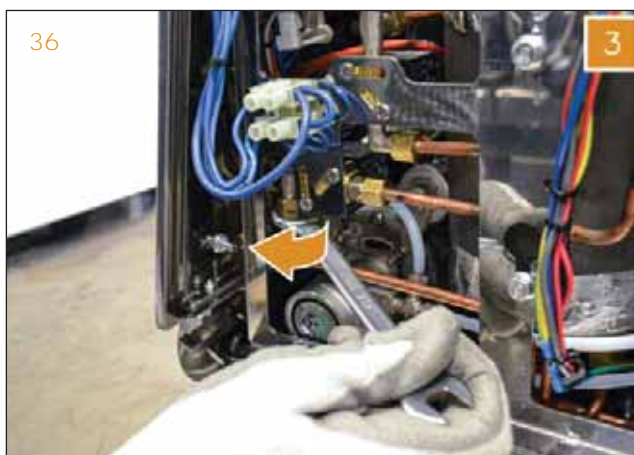

- Utilizing a 13 mm and a 12 mm wrenches, disconnect the inlet pipe from the auto-fill valve.



- Utilizing a Philips screwdriver, unscrew the two screws.



- Extract the auto-fill valve from the upper side and disconnect the cables.



7.6 FLOWMETER AND NOT RETURN VALVE

To set the coffee dose, the machine has a flowmeter, also called fan.

It is located on front-right side of the machine.

The issues related to the flowmeter are those that can be found when dosing coffee, therefore only when using the pre-set dosage buttons.

WHEN TO INTERVENE

The most common errors that you may encounter are:

- 1 Wires disconnected accidentally or unintentionally (i.e. after replacing a card).
- 2 There are impurities in the filter at the entrance of the fan.
- 3 The coil of the magnetic sensor has deteriorated and no longer reads the values correctly.
- 4 The not return valve is blocked.

If one of these cases occurs, pressing one of the settable buttons, the machine does not make coffee and does not stop (obstruction to the limit), or it can happen that the delivery does not stop as planned.

In these cases the key pressed with the settable button could flash to highlight a malfunction.

NOTE

For further information on the flowmeter alarm, refer to Chapter 10.

Even if the programmed doses do not work, the machine will always operate in semi-automatic mode using only the start/stop button until the arrival of the technician.

To verify that the fan is effectively locked you can:

- 1 Check function by measuring the voltage supplied to the control unit during a delivery.
- 2 Directly inspect the part.



HOW TO VERIFY THE SIGNAL OF THE FLOWMETER

To measure the signal it is necessary to access to the control unit located on the right side.

1 Remove the right side panel as shown in Chapter 3.

2 With a tester measure the voltage alternating between the ends of the faulty flowmeter (see figure). Place the tester caps at the terminals of the doser using the references in the image.

The signal generated by the fan is a square wave of about 5V.

If the dispenser is damaged we cannot read anything.

7.6.1 REMOVAL OF THE FLOWMETER

To remove the flowmeter, proceed as it follows:

1 Remove the cup holder surface, the side panels, the drip tray and the lower front panel as described in Chapter 3.

2 Utilizing a Philips screwdriver, unscrew and remove the head from the flowmeter.

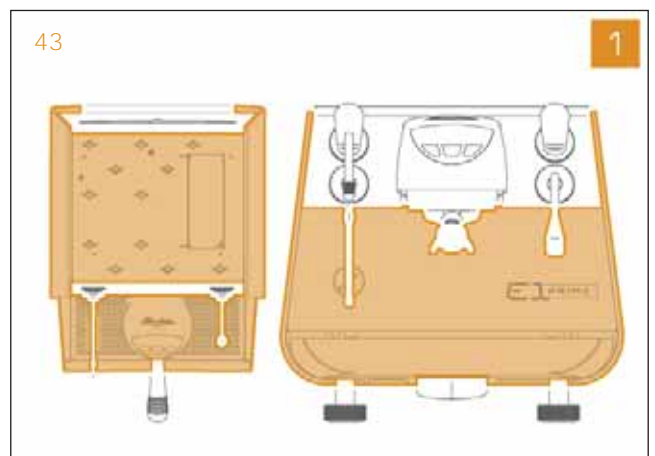

- 3 Utilizing a 14 mm and 17 mm wrenches, remove the outgoing pipe from the flowmeter.



- 4 Utilizing a 12 mm and 13 mm wrenches, remove the not return valve.



- 5 Utilizing two 17 mm wrenches, remove the inlet pipe from the flowmeter.



- 6 Utilizing a small Philips screwdriver, remove the two screws that keep the flowmeter on the bracket.



NOTE

Position a cloth or absorbent paper underneath the small fan.

The flowmeter is made of various parts, as shown in the picture.

It is good practice to substitute the gaskets each time it is completely inspected.

Check that there is no limestone in the fan input grid, unscrew the three screws that hold the cover and check that there is nothing to obstruct the regular operation.

To remove the filter, if it is particularly clogged, you can use a simple piece of wire to push the filter, if necessary even a common clip is sufficient.

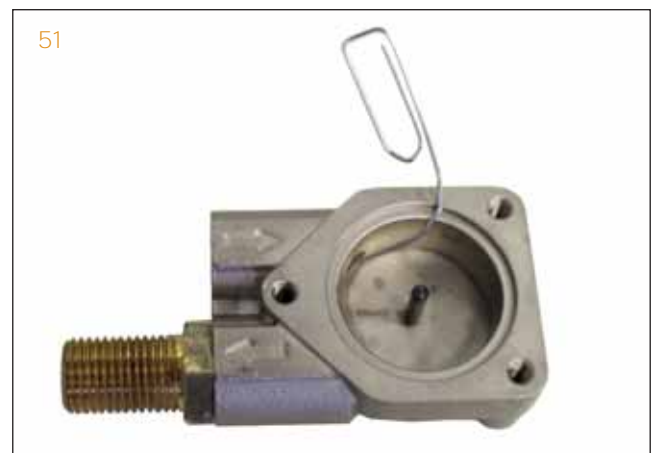
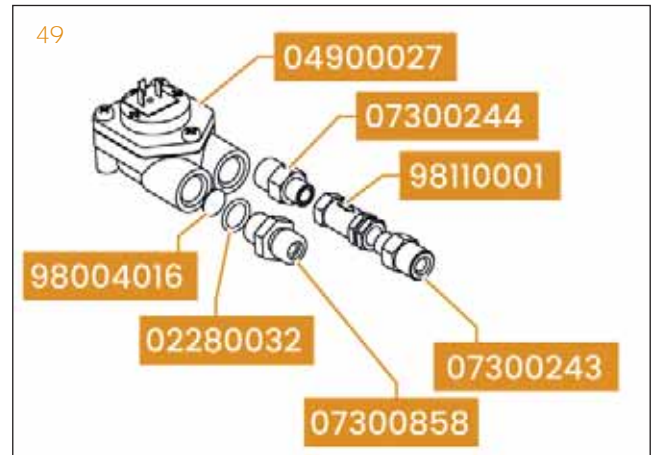

7.6.2 REMOVAL OF THE PRE INFUSION RESTRICTOR

Attention must be given to the restrictor at the exit from the flowmeter. It is called pre-infusion restrictor, since its size effects the pre-infusion time: bigger is the size, shorter is the pre-infusion.

The default restrictor is 0.5 mm, welded in the fitting, and an optional one of 0.8 mm is available.

To clean it, proceed as it follows:

- 1 Follow the first 4 steps of the paragraph 7.6.1.
- 2 If the restrictor is welded in the fitting, it is only possible to clean it with a needle. If the restrictor is not welded, it is possible to remove it utilizing a 4 mm Allen key.

7.6.3 REMOVAL OF THE NOT-RETURN VALVE

To remove the not return valve, proceed as it follows:

- 1 Follow the first 4 steps of the paragraph 7.6.1.
- 2 Utilizing a 13 mm and 14 mm wrenches, remove the fitting.

NOTE

We recommend changing the not return valve located down-stream of flowmeter at least once a year.

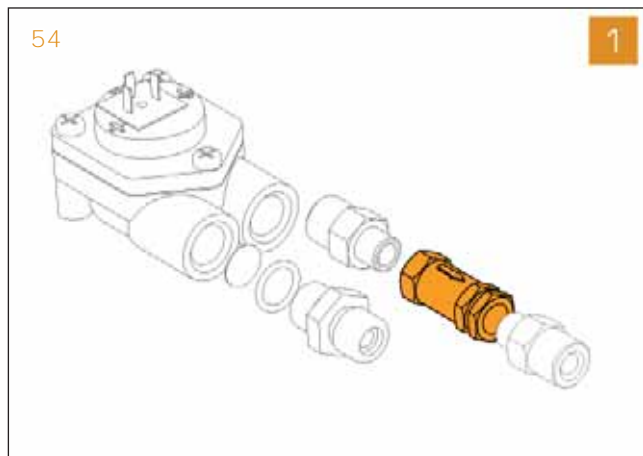
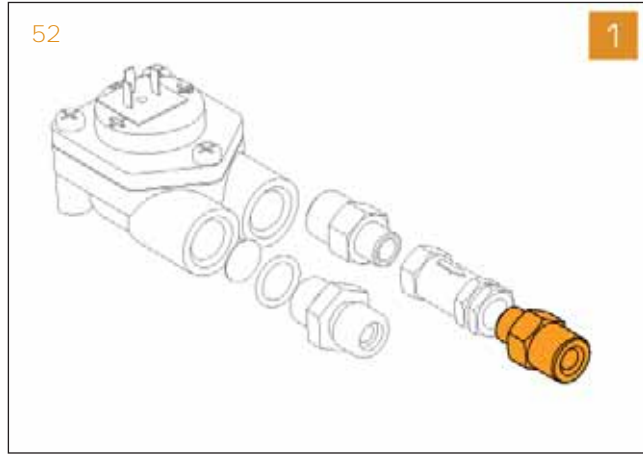

7.7 HOT AND COLD WATER VALVE

The **EI PRIMA** is provided with a cold water valve with adjustable mixer.

In this way the outlet water temperature can be lowered by mixing hot water from the boiler with cold water from the network, thus reducing the levy in the boiler and consequently saving on heating.

For this reason it is commonly called economizer of hot water.

HOW TO ADJUST THE TEMPERATURE

To adjust the temperature, simply use a flat screwdriver while the water is running.

To reduce the temperature, rotate the screw positioned on the left side of the cup holder surface in an counter-clockwise direction.

To increase the temperature, turn the screw in a clockwise direction.

NOTE

Do not reduce the temperature too much, otherwise the valve could emit an annoying noise.

WHEN TO INTERVENE

Problems that can be encountered in the economizing unit are:

- 1 Failure to deliver water.
- 2 Delivers only hot or only cold water.
- 3 Continuous dripping.
- 4 Erroneous programming.

Cases **1**, **2** and **3** are due to malfunction of the valves so you need to access them and verify that they are working properly.

The valve may stop operating due to electrical problems or is not working properly due to obstructions for example caused by pieces of limestone that detach from the boiler and clog the valve.

If both valves do not work and the classic opening and closing noise is not heard, there could be a problem with the relay in the control unit, therefore it is necessary to directly measure the voltage with a tester while water is being dispensed.



07

Position the tip at the point shown in the figure during delivery, considering that the hot water and cold water valves are parallel, simply verify the operation of this relay to check both valves.

7.7.1 REMOVAL OF THE HOT WATER VALVE

To remove the hot water valve, it is necessary to extract both hot and cold water valves. Proceed as it follows:

- 1 Empty the steam boiler by following the procedure described in paragraph 5.2.

NOTE

It is not possible to operate with pressure in the steam boiler.

- 2 Remove the cup holder surface and the left side panel as described in Chapter 3.

- 3 Utilizing a 13 mm wrench, remove the inlet pipe of hot water.

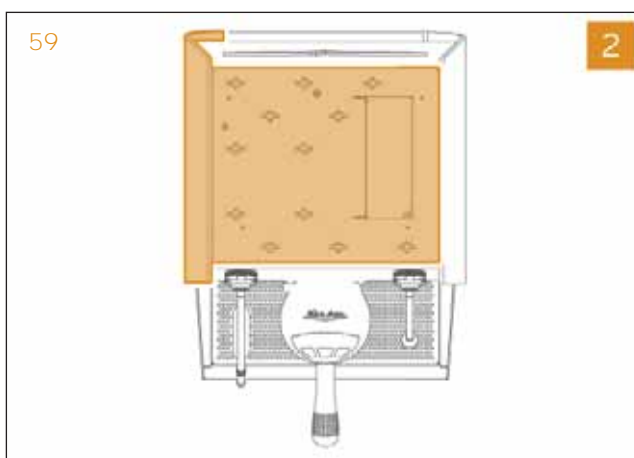

- Utilizing a 13 mm wrench, remove the outgoing pipe from the hot and cold water valves.

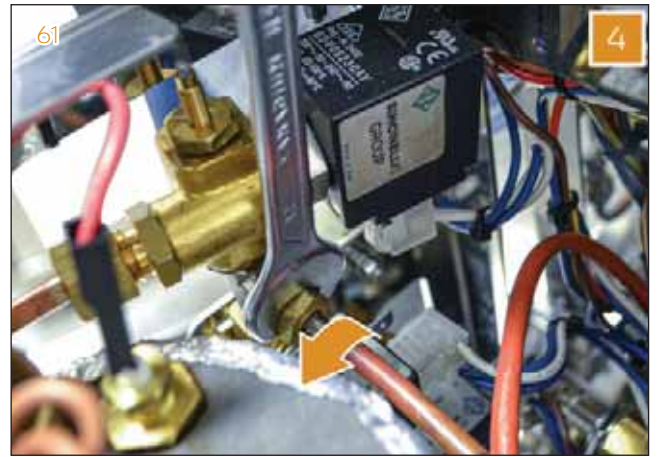

- Utilizing two 17 mm wrenches, remove the inlet pipe from the cold water valve.



- Utilizing a Philips screwdriver, remove the two screws that keep the hot water valve.



- Extract the valves from the upper side and disconnect the cables.



To check the hot water valve:

8 Utilizing a 14 mm wrench, unscrew the nut and remove the coil of the valve.



9 Utilizing a 14 mm wrench, unscrew the valve base.



10 Check that the spring is working properly and that the inner cylinder is clean.



NOTE

If there is nothing visible that affects its use, replace the valve completely.



To replace the hot water valve:

11 Utilizing a vise and a 10 mm wrench, divide the hot and cold water valves.

NOTE

When reassembling the valves, use Loctite glue in the fitting.



7.7.2 REMOVAL OF THE COLD WATER VALVE

To remove the cold water valve follow the first 10 steps of the previous paragraph.

Since the cold water valve is connected with a tap, it may be necessary to replace the whole part.

7.8 STEAM VALVE

The **EI PRIMA** is not provided with a mechanical steam tap controlled by a manual lever, but with a three-way solenoid valve controlled electronically. This will reduce the needed maintenance to maintain a constant functioning of the steam service.

WHEN TO INTERVENE

Problems that can be encountered in the steam service are:

- 1 Failure to deliver steam.
- 2 Continuous low steam flow.
- 3 Erroneous programming.

Cases **1** and **2** are due to malfunction of the valve so you need to access it and verify that it is working properly.

The valve may stop operating due to electrical problems or is not working properly due to obstructions for example caused by pieces of limestone that detach from the boiler and clog the valve.

If the valve does not work and the classic opening and closing noise is not heard, there could be a problem with the relay in the control unit, therefore it is necessary to directly measure the voltage with a tester while steam is being dispensed, positioning the tip at the point shown in the figure during delivery.

7.8.1 REMOVAL OF THE STEAM VALVE

To remove the steam valve proceed as it follows:

- 1 Lower the steam boiler pressure by following the procedure described in paragraph 5.1.

NOTE

It is not possible to operate with pressure in the steam boiler.

NOTE

The same steam valve, in the same position, is used for the Easycream (optional).



2 Turn the machine OFF.



3 Remove the cup holder surface. The steam valve (A) is located on the right side, between the tank and the coffee boiler.



4 Utilizing a 14 mm and 17 mm wrenches, remove the incoming copper pipe from the boiler.



5 Utilizing a 13 mm and 17 mm wrenches, keep the T connection and remove the outgoing copper pipe.



6 Extract the valve and disconnect the cables.



7 Cut the clamp and remove the Teflon pipe of the third outlet.



8 Utilizing a 13 mm wrench, unscrew the nut and remove the coil of the valve.



9 Utilizing a vise and a 16 mm wrench, unscrew the valve base.

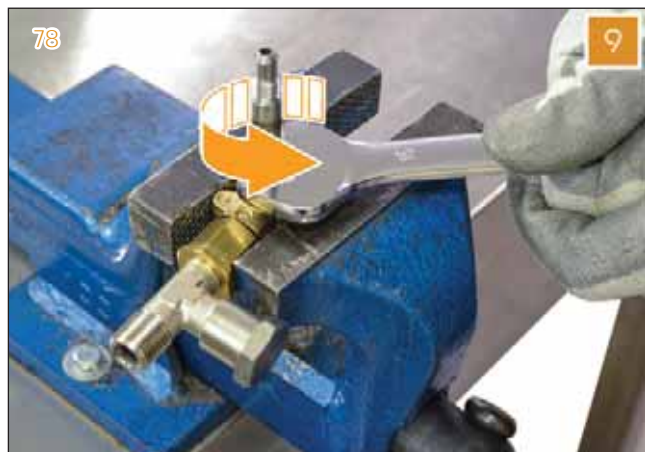

10 Check that the spring is working properly and that the inner cylinder is clean.



11 If the replacement of the valve body is necessary, utilize a 14 mm and 16 mm wrenches to disassemble the valve.



NOTE

If there is nothing visible that affects its use, replace the valve completely.

7.9 STEAM, HOT WATER AND EASYCREAM (OPTIONAL) WANDS

All wands are composed of a joint, a junction and a nozzle. These parts are equipped with o-rings to avoid leaks.

Steam and Easycream (optional) wands are **“cool touch”** type. Thanks to the presence of an internal Teflon pipe, do not heat up quickly. In this way, the barista has the chance to work more comfortably even on an ongoing basis, without the fear that the steam wand may reach excessive temperatures.

WHEN TO INTERVENE

In case of leaks or of low flow it can be necessary to dismantle the wand to replace o-rings, or the Teflon pipe, or to clean the water diffuser head.

NOTE

To know standard suggested maintenance on the wands, refer to Chapter 11.

7.9.1 DISMANTLING THE WAND

The procedure to dismantle steam, hot water and Easycream wands, is basically the same. Proceed as it follows.

- 1 Turn the machine OFF.
- 2 Remove the cup holder surface and the left side panel, in case of the steam wand, or remove the cup holder surface and the right side panel for the hot water wand as described in Chapter 3.

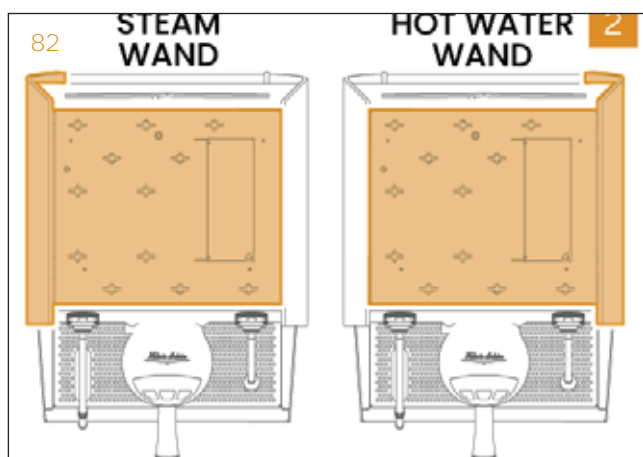
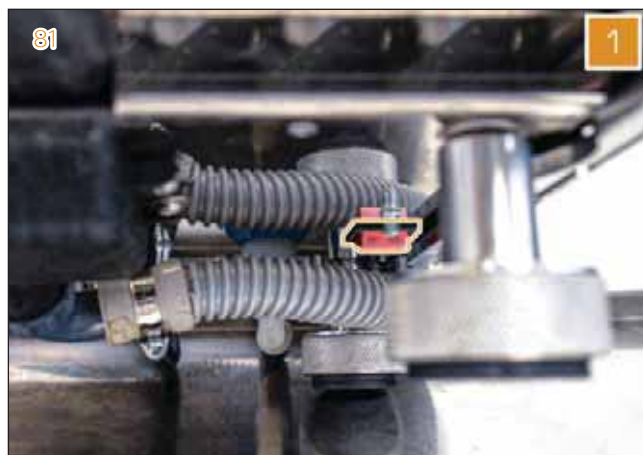

- 3 Using plier and cloth or paper to avoid damage, or simply by hand, unscrew the final part of the nozzle.



- 4 Utilizing a 9 mm wrench, block the upper part of the wand and, by hand, unscrew the middle part of the nozzle.



- 5 Utilizing a 24 mm wrench and a 20 mm one, block the front fitting and unscrew the copper pipe.



- 6 Utilizing a 24 mm wrench, loosen the fitting.

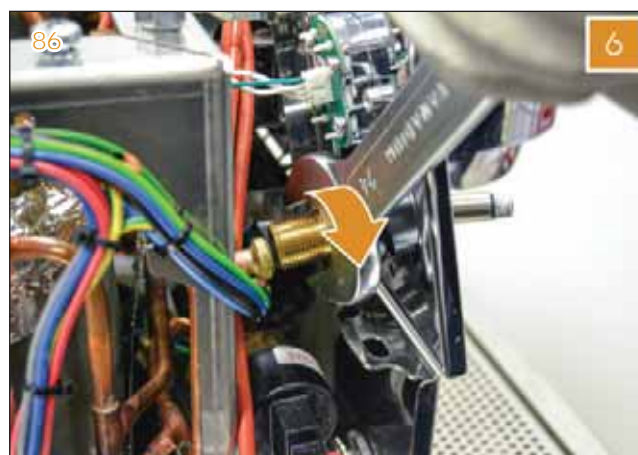

- 7 Utilizing a 3 mm Allen key, remove the two screws keeping the joint of the wand.



- 8 Utilizing a 24 mm wrench or simply by hand, remove the fitting.



- 9 The junction is visible now, with its spring. Notice that there is a white Teflon o-ring inside the joint.



NOTE

The steam wand is composed by many parts equipped with different o-rings and Teflon pipe. It can be needed to change o-rings in case of leaks and to change the Teflon pipe in case of low steam flow.

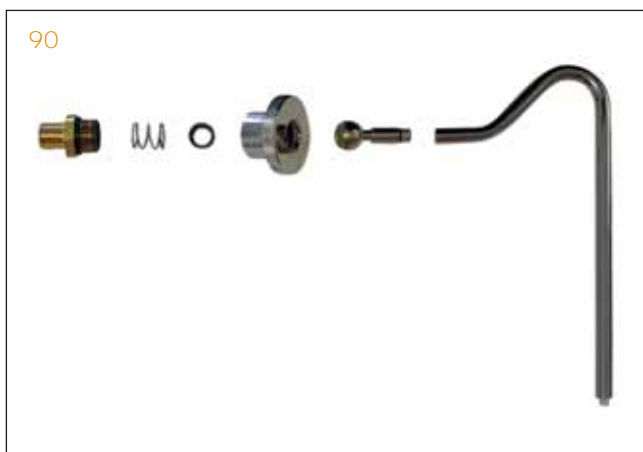

NOTE

To remove the Easycream wand, it is necessary to disconnect the temperature probe wire too.

NOTE

The final part of the hot water wand includes the water diffuser head. It can be needed to clean it if the water flow is not regular.



7.10 EASYCREAM (OPTIONAL)

The **EI PRIMA** is also available with the Easycream system, which allows the barista to obtain a dense, velvety milk cream quickly and automatically.

Easycream is composed by a steam wand and a temperature probe.

The steam wand is connected to steam boiler (A) and to an air compressor (B), so that it can dispense steam and air.

Easycream needs two kind of settings. One is software and one is mechanical. As software setting, in the programming there are three parameters to set:

- **Delay (sec):** is a delay for the air. When Easycream begins, steam comes out without air to start the rolling phase, then after the delay time the air solenoid valve opens and the compressor starts to push air into the circuit together with steam, foaming the milk. This time is to avoid the big bubbles creating at the beginning. Suggested value is 1.5 sec, as in the example.
- **AirTemp (°C):** is the temperature when the air stops. The temperature probe checks continuously the milk temperature. Air is injected by the compressor into the circuit till the AirTemp parameter, and then only steam comes out to roll the milk with the foam creating the micro-bubbles. Increasing this parameter gives more quantity of foam, decreasing it gives less quantity of foam. Value is 40.0°C in the example.
- **FinalTemp (°C):** The mechanical setting consists in to adjust the air tap on top of the machine to get a proper foam quality. It is a flat screw to open and close the air. The machine arrives with a basic setting, but if a maintenance has been done, the starting point is to close completely the screw clockwise and then open anti-clockwise about 2 complete turns. Value is 65.0°C in the example.

93



94

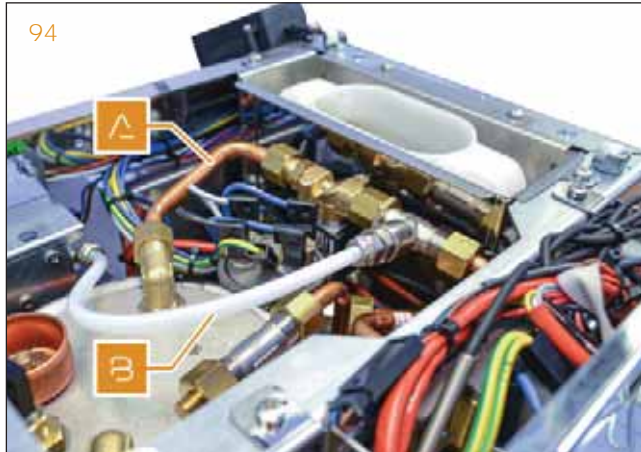

95

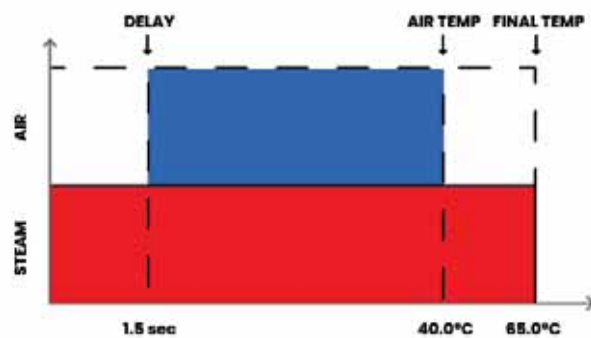

The mechanical setting consists in to adjust the air tap on top of the machine to get a proper foam quality.

It is a flat screw to open and close the air.

The machine arrives with a basic setting, but if a maintenance has been done, the starting point is to close completely the screw clockwise and then open anti-clockwise about 2 complete turns.

HOW TO SET



DANGER

This operation is carried out with the machine switched ON so as to perfectly fine tune the air valve.

To set the Easycream, proceed as it follows.

- 1 Utilizing the **Victoria Arduino E1 App**, in the programming of the **MACHINE SETTING**, enable Easycream and save.

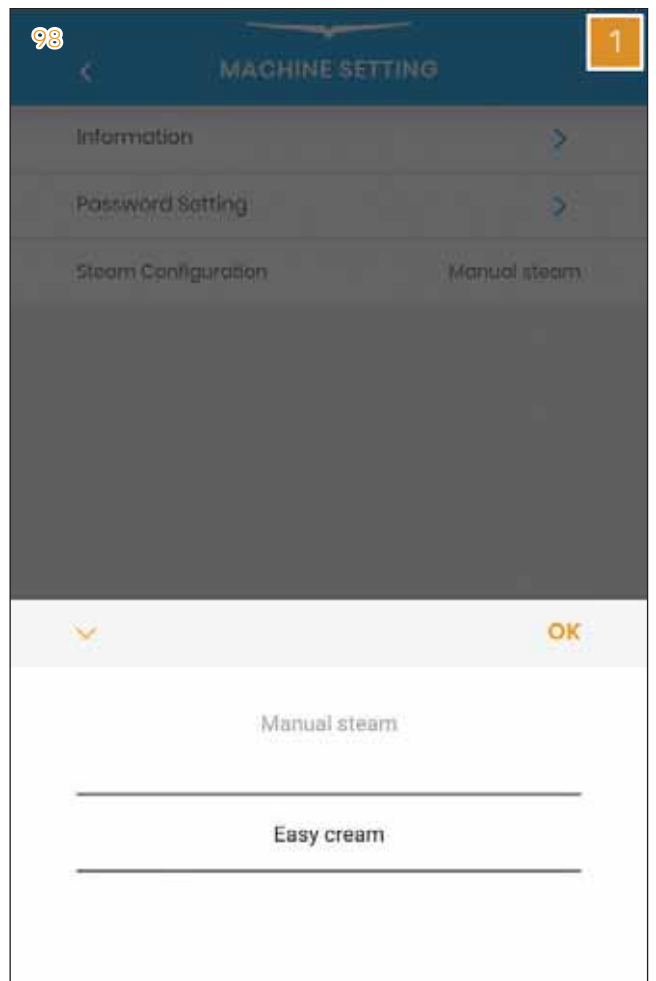

- Utilizing the **Victoria Arduino EI App**, in the programming of the **MYCOFFEE** recipe, set the Easycream parameters and save.

NOTE

There are two different settings for the Easycream, since Easycream button can be pushed up (Key 1) or down (Key 2) to have two different Easycream recipes.

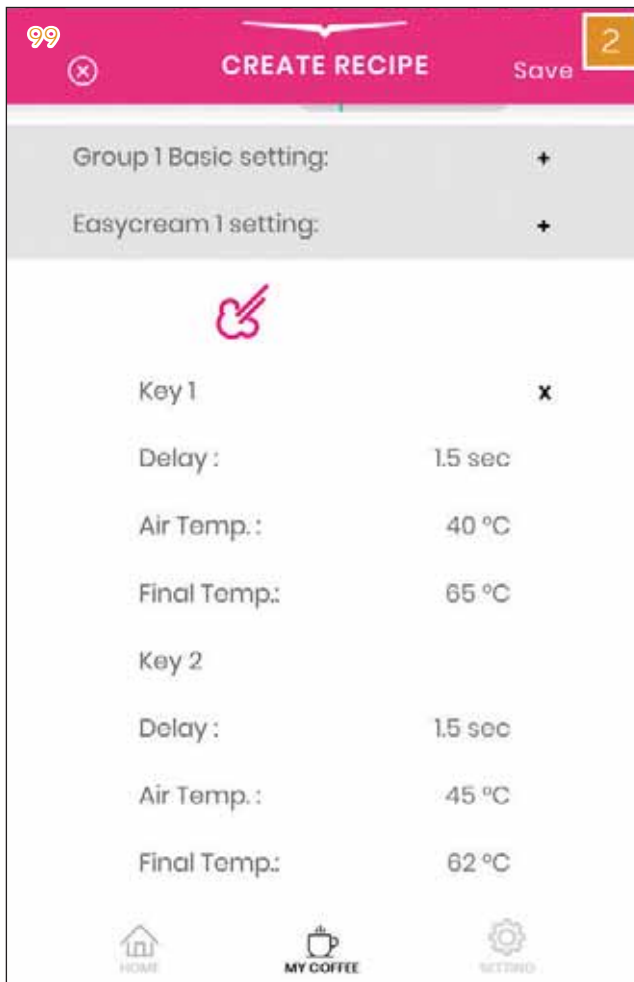

- Put milk in a frothing jug under the Easycream wand and start the button.

- Utilizing a flat screwdriver, while the Easycream is running, set the air screw.

NOTE

To dismantle the wand, follow the procedure as explained in previous paragraph 7.9.1.



7.11 REMOVAL OF THE PRESSURE GAUGE

The **E1 PRIMA** is provided with a pressure gauge that permits to read the steam boiler pressure.

To remove it, proceed as it follows:

- 1 Lower the steam boiler pressure by following the procedure described in paragraph 5.1.

NOTE

It is not possible to operate with pressure in the steam boiler.

- 2 Turn the machine OFF.
- 3 Remove the cup holder surface, the side panels, the drip tray and the lower front panel as described in Chapter 3.
- 4 Utilizing a 13 mm wrench, unscrew the copper pipe.

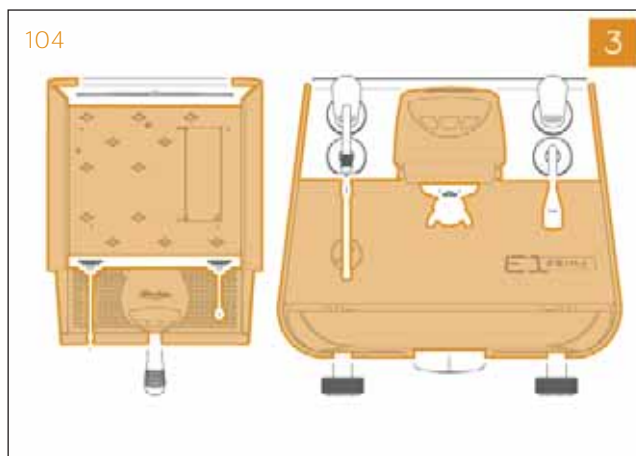
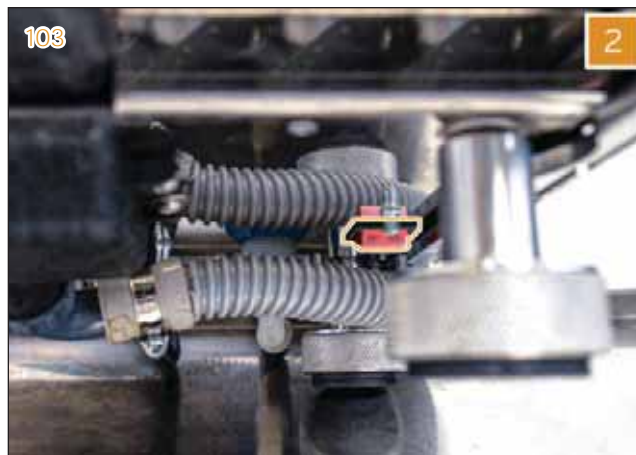

5 Utilizing a 12 mm and a 13 mm wrenches, block the pressure gauge and loosen the nut.

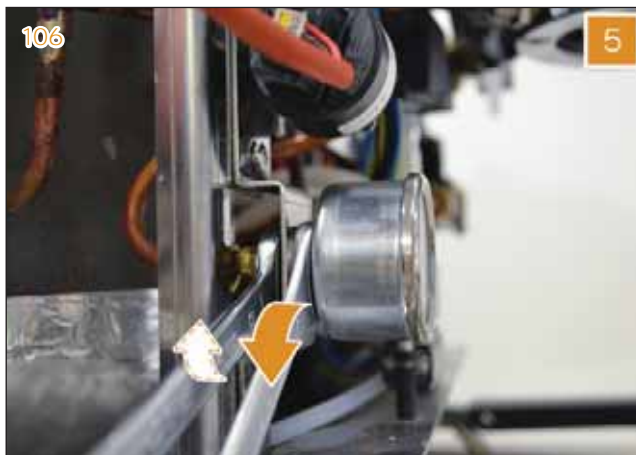

6 Utilizing a 13 mm wrench, keep the nut and loosen the pressure gauge by hand.



07

08

ELECTRIC COMPONENTS



08

INDEX

08	ELECTRIC COMPONENTS	123
8.1	CONTROL UNIT	124
8.1.1	CONTROL UNIT LEDS	128
8.2	CONTACTOR	129
8.3	STATIC RELAY	130
8.4	TRANSFORMER	131
8.5	PRESSURE TRANSDUCERS	133
8.5.1	REMOVAL OF THE WATER PRESSURE TRANSDUCER	133
8.5.2	REMOVAL OF THE STEAM BOILER PRESSURE TRANSDUCER	134
8.6	GROUP COVER AND SERVICE BOARD	135
8.7	SERVICE KNOB	137
8.8	WATER TANK PRESENCE SENSOR	138
8.9	LIGHTS	139





WARNING

Before proceeding with the operations described in this chapter, make sure that the machine is turned OFF and unplugged from the mains.

8.1 CONTROL UNIT

To access the control unit it is necessary to remove the cup holder surface and the right side panel, as described in Chapter 3.

01



02

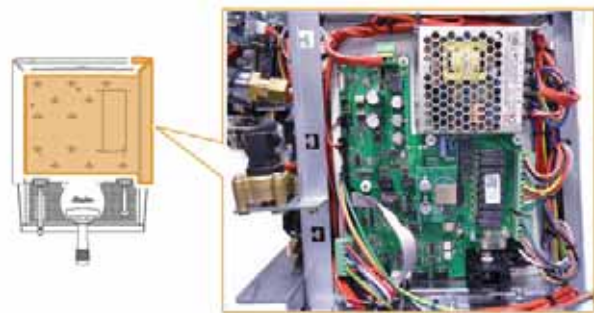

03



04

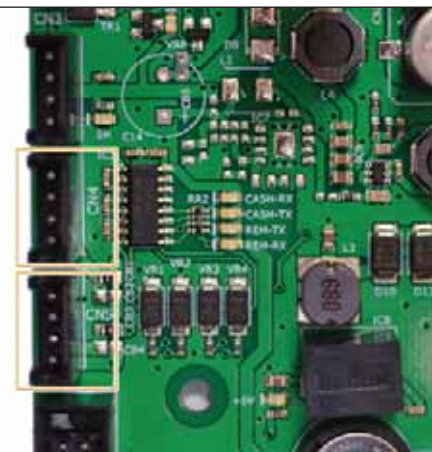

The control unit without connections appears as shown in the figure.

Writings on the control unit help to easily identify the connection terminals.

For example, the focus on the picture shows the codes **CN4** and **CN5**.

The same codes are used here below.



FOCUS ON THE VARIOUS PARTS

Battery and fuses:

- F1** 2 Ampere fuse:
low power IN (+24VDC) fuse.
- F2** 6.3 Ampere fuse:
power IN (+230VAC) fuse to solenoid
valves, pump and contactor.
- F3** 6.3 Ampere fuse:
power IN (+230VAC) fuse to coffee
boiler's and group's heating elements.
- BT1** CR1220 3 Volt battery:
to store date and time.

Upper side, "low voltage":

- CN20** low power IN (+24VDC) from the
transformer.

Left side, "low voltage":

- USB** USB port.
- CN1** compressor
(only with the Easycream optional).
- CN2** rear led bar and group spot led.
- CN3** static relay.
- CN4** none.
- CN5** remote control module.
- CN6** group service board flat cable.
- CN7** none.
- CN8** 6 pins green terminal for level probe
and flowmeter, see details below.

In details, regarding to **CN8**, 6 pins green terminal for the level probe and flowmeter:

PIN	CABLE COLOUR	DESCRIPTION
1	Red	Level Probe
2	Blue	Flowmeter ground
3	-	None
4	White	Flowmeter impulses
5	Yellow	Ground
	Green	
6	Red	Flowmeter power supply (+12VDC)

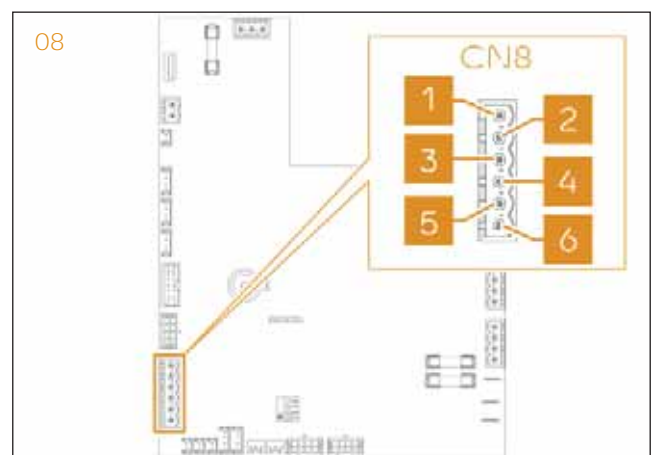
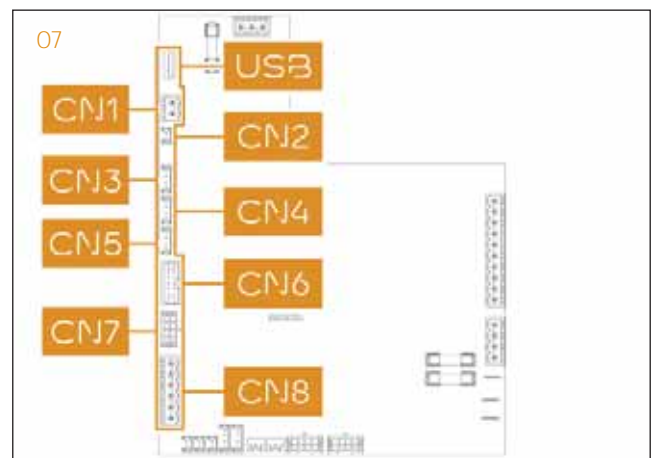
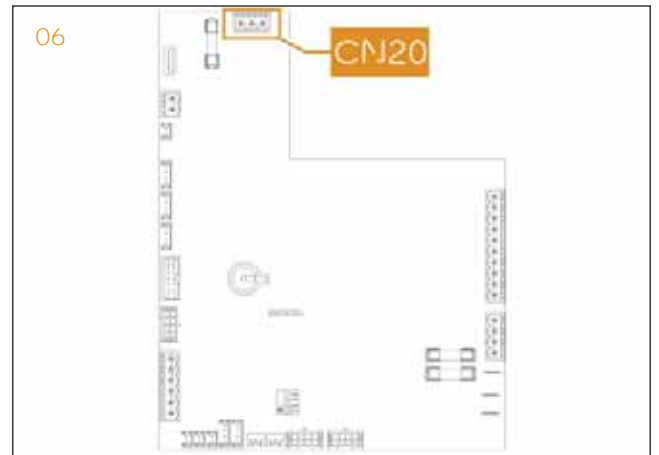
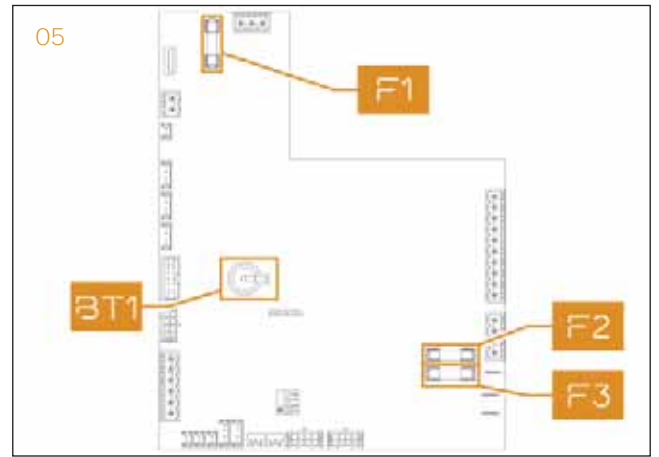

Lower side, "low voltage":

- 1 Temperature probes, see details below.
- 2 Presence sensors, see details below.
- 3 Pressure transducers, see details below.

CN16 none.

CN17 none.

SW1 DIP switch: all to OFF, used only by the manufacturer.

In details, regarding to temperature probes:

CN9 coffee boiler temperature probe.

CN10 coffee group temperature probe.

CN11 Easycream temperature probe (only with the Easycream optional).

In details, regarding to presence sensors:

CN12 filter holder presence sensor.

CN13 water tank presence sensor.

In details, regarding to pressure transducers:

CN14 water pressure transducer.

CN15 steam boiler pressure transducer.

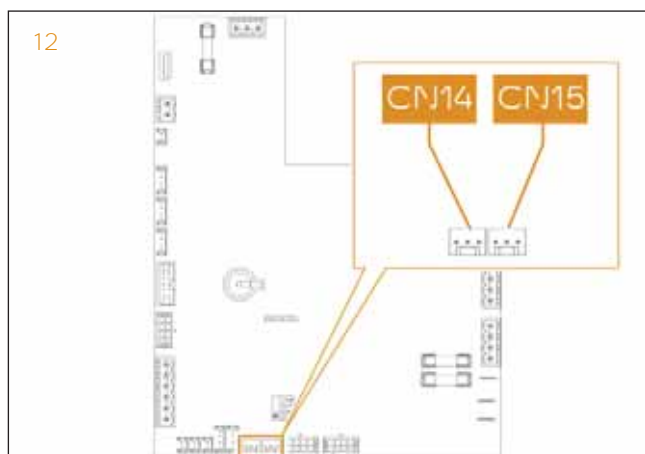
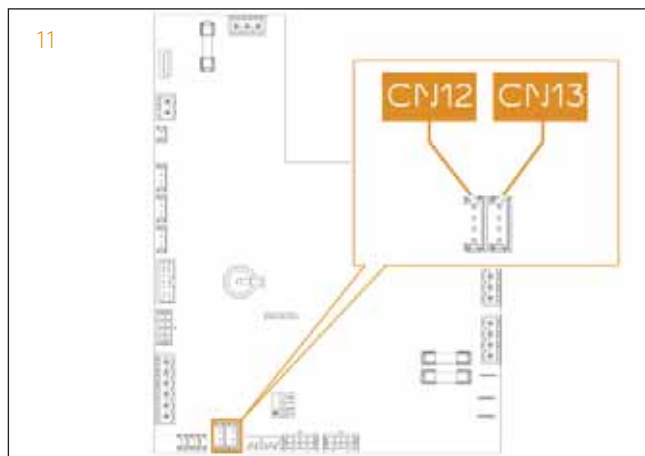
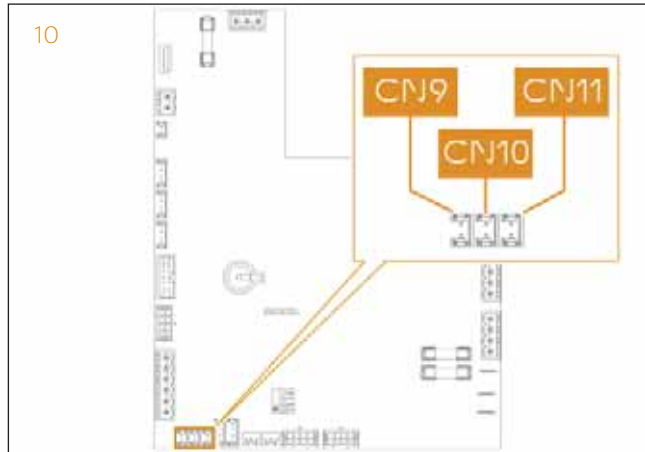
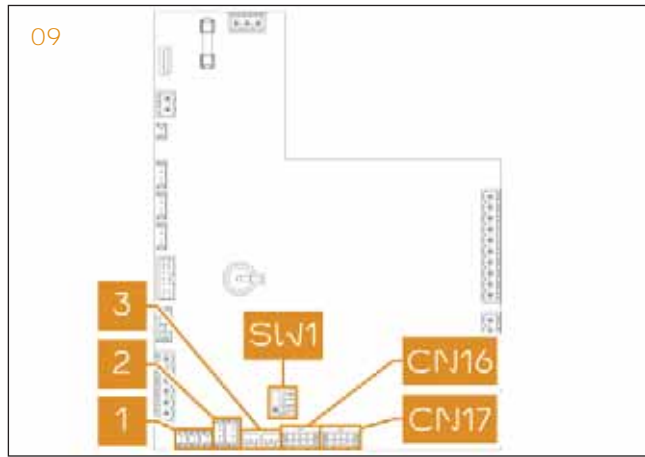

Right side, "high voltage":

CN18 power IN (+230VAC).

CN19 10 pins green terminal for pump, contactor and solenoid valves, see details below.

FS1 static relay.

FS2 coffee group's heating element.

FS3 coffee boiler's heating element.

In details, regarding to **CN19**, the 10 pins green terminal:

PIN	CABLE COLOUR	DESCRIPTION
1	Orange	Pump
2	Black	Tank valve
3	Violet	Water stop valve
4	-	None
5	Light brown	Easycream air valve (optional)
6	Yellow	Steam valve
7	Red	Contactor
8	Brown	Self-levelling valve
9	White	Hot and cold water valves
10	Green	Coffee valve

NOTE

For further information on electrical connections, follow electrical diagrams on Chapter 13.

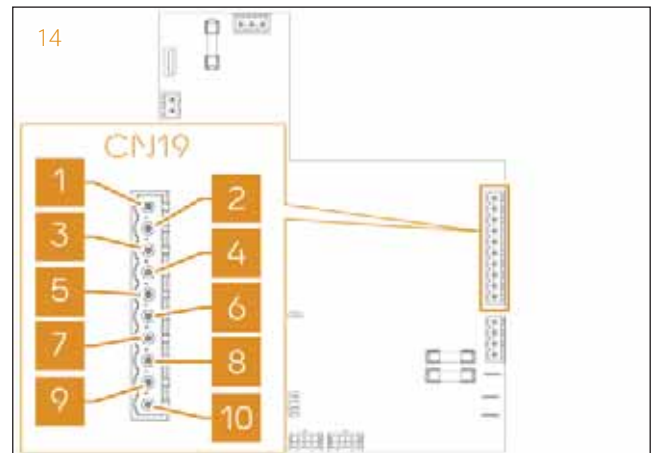
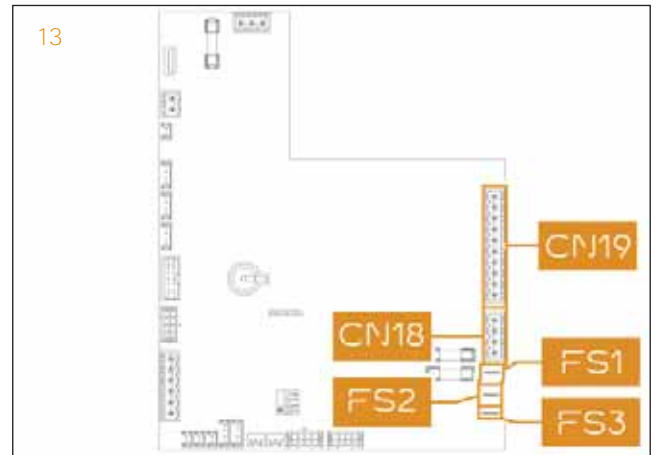

8.1.1 CONTROL UNIT LEDS

The control unit contains LEDs, useful to recognize the functioning of parts of the machine.

There is a writing next to each LED to indicate what it refers to. For example, the focus on the picture shows the writing **SH**, that indicates the activation of the static relay.

Every LED can have a different meaning, based on the part it refers to. It can mean for example: that function is fine, or the control unit is turning ON that part, or the control unit is receiving signal from that part.

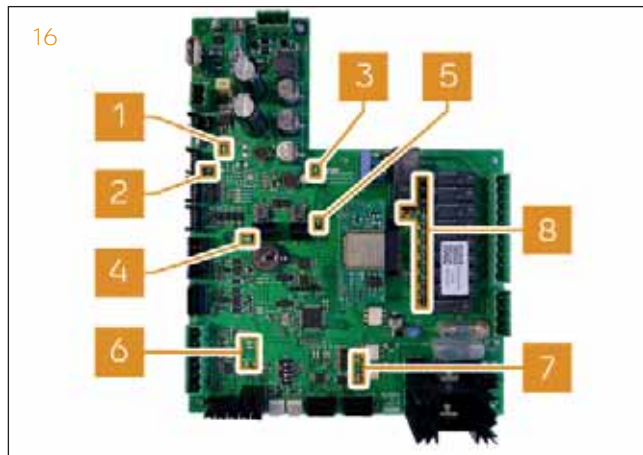
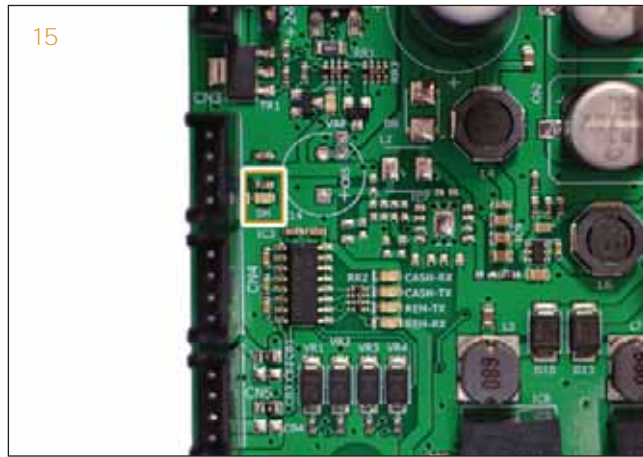

The most useful LEDs are:

POSITION ON THE IMAGE	WRITING NEXT TO LED	RELATIVE TO
1	VAP	Compressor
2	SH	Static relay
3	+12V	Power supply +12VDC
4	+5V	Power supply +5VDC
5	+3V3	Power supply +3.3VDC
6	LEV	Tank level
	VOL	Flowmeter
7	PF-GR	Filter holder presence sensor
	GR	Coffee group's heating element
	CH	Coffee boiler's heating element
8	TANICA	Tank valve
	H2O-STOP	Water stop valve
	PULSEJET	None
	PUMP	Pump
	AIR-VAP	Easycream air valve
	EVVAP	Steam valve
	ON-OFF	Contacteur
	AUTOLIV	Self-levelling valve
	H2O-THE	Hot and cold water valves
	EV-GR	Coffee valve



8.2 CONTACTOR

The contactor (**A**) is placed on the rear side of the machine, so it possible to access it by removing the rear panel, as described in chapter 3.

It is a relay that enables the heating phase of the machine. It interrupts the neutral and the phase and the enabling is established by the control unit. In fact, when the machine is switched ON, the water level is controlled and, after the positive results, the contactor is enabled by the control unit.

PROBLEMS

Normally, the contactor makes a characteristic noise when it closes the circuit, so if you cannot hear the typical noise, it is possible that the problem is upstream (level probe) or with the contactor itself.

REPLACEMENT

To replace the contactor, proceed as it follows:

- 1 Utilizing a Philips screwdriver, remove the right screw.
- 2 Utilizing a Philips screwdriver, loosen the left screw and pull out the contactor.
- 3 Unplug all the cables.

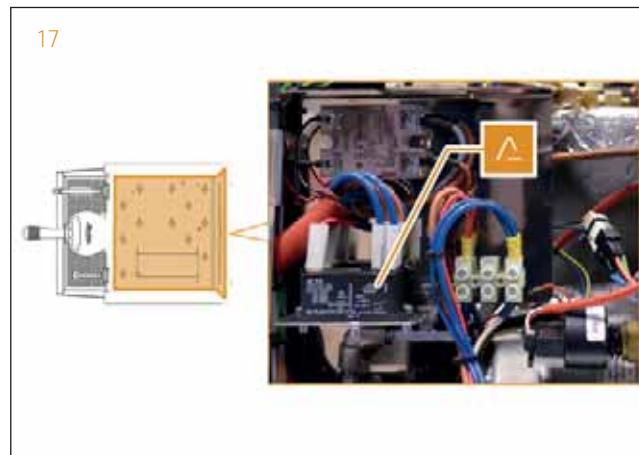

8.3 STATIC RELAY

The static relay (**B**) is placed on the rear side of the machine above the contactor, so it is possible to access it by removing the rear panel, as described in chapter 3.

It controls the heating element of the steam boiler. It is activated when the pressure transducer detects a pressure lower than that set.

The voltage availability is enabled by the contactor. The switch ON/OFF command is piloted by the control unit.

The right connections, **LOAD**, are the incoming phase (**1**) and the outgoing phase (**2**). The left ones, **INPUT** (**3** and **4**), are the commands from to the control unit.

The operation is checked by means of LED that light up in the heating phase of the machine.

To test, simply let out a lot of steam from the steam nozzle until the heating element starts again.

Optimum operation will be when impulses are spaced at varying intervals.

It is possible to verify LED on the control unit too.

The static relay's LED is labelled with **SH**, as explained in paragraph 8.1.1.

PROBLEMS

The static relay can be damaged in ON or OFF status, thereby giving high or low pressure in the steam boiler.

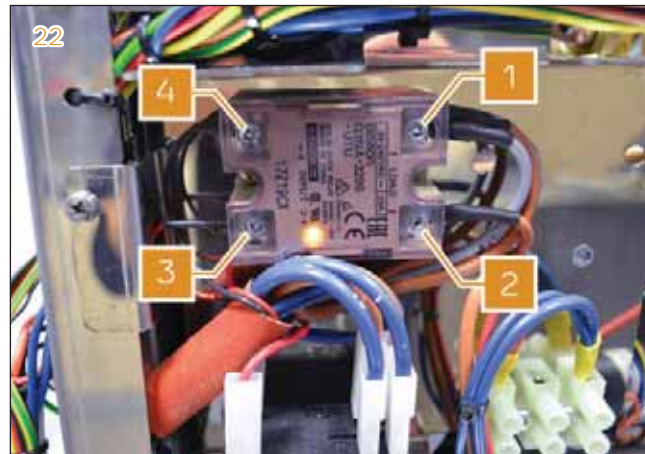
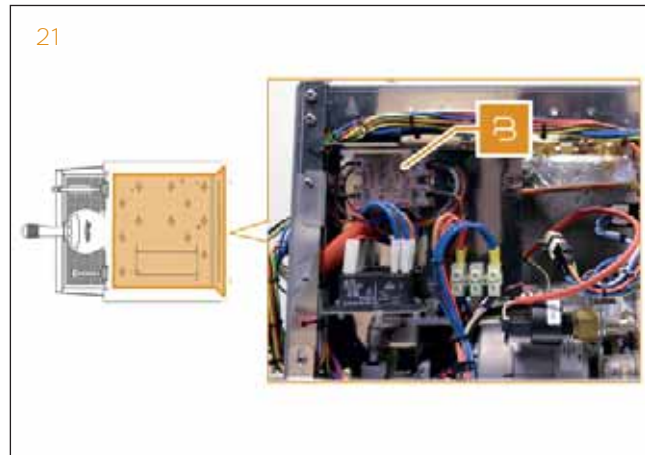

REPLACEMENT

To replace the static relay, proceed as it follows:

- 1 Utilizing a Philips screwdriver, remove the right screw.
- 2 Utilizing a Philips screwdriver, loosen the left screw and pull out the static relay.
- 3 Utilizing a Philips screwdriver, loosen the four screws and remove the cables.

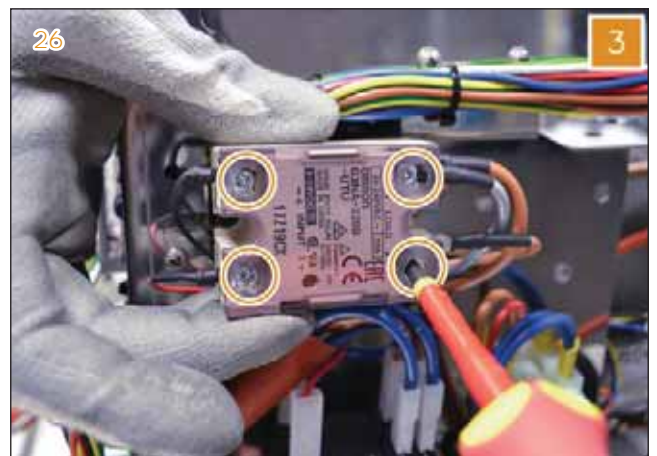

8.4 TRANSFORMER

The machine provides VDC to the control unit and to some components thanks to a transformer, not included in the control unit, but separated.

The transformer (C) is located near the control unit, hence, to access it is necessary to remove the cup holder surface and the right side panel, as described in Chapter 3.

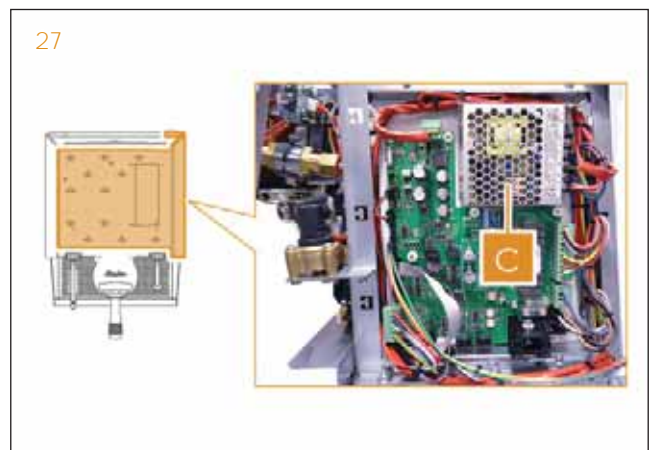

Looking at the connections the visible parts are:

- A Outputs
- B Inputs

The outputs are connected to the control unit on **CN20**, as explained in paragraph 8.1.

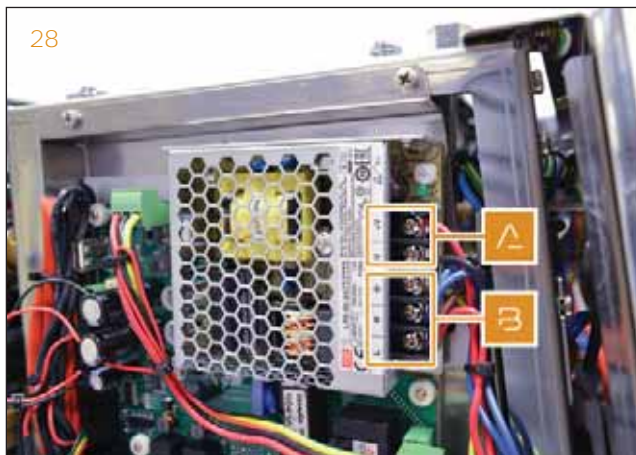

REPLACEMENT

If the outputs do not give **+24VDC** the transformer is broken.

In this case the control unit and the machine will appear completely OFF.

To replace the transformer, proceed as it follows:

1 Utilizing a 2,5 mm Allen key, remove the screw on the down-right corner.

2 Utilizing a 2,5 mm Allen key, loosen the screw on the top-left corner and pull out the transformer.

3 Utilizing a Philips screwdriver, loosen the five screws and remove the cables.



8.5 PRESSURE TRANSDUCERS

The **EI PRIMA** is equipped with two pressure transducers: one reads the pressure of the water after the pump and one reads the steam boiler pressure.

As explained in paragraph 8.1, they are connected to the control unit:

- A The water pressure transducer on **CN14**.
- B The steam boiler pressure transducer on **CN15**.

NOTE

The cable of the steam boiler pressure transducer has a red label to recognise it.

If the pressure in the smartphone app **Victoria Arduino EI** is unshown or certainly wrong, check the cabling or replace the proper pressure transducer.

8.5.1 REMOVAL OF THE WATER PRESSURE TRANSDUCER

The water pressure transducer is placed on the back of the machine. To remove it, proceed as it follows:

- 1 Remove the cup holder surface, the side panels and the rear panel, as described in chapter 3.
- 2 Unplug the connector.

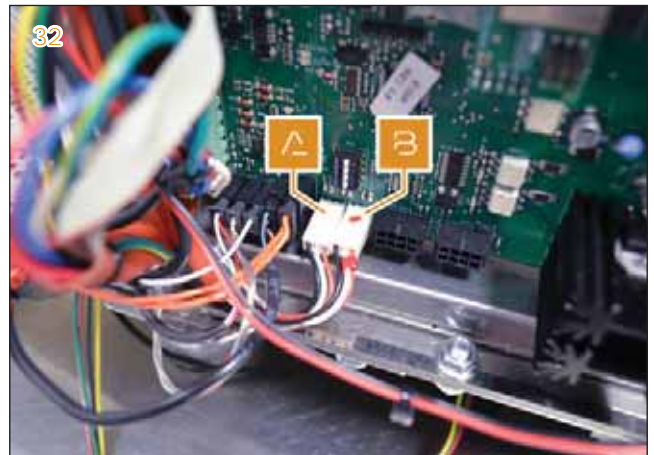

- 3 Unscrew and remove the pressure transducer by hand.

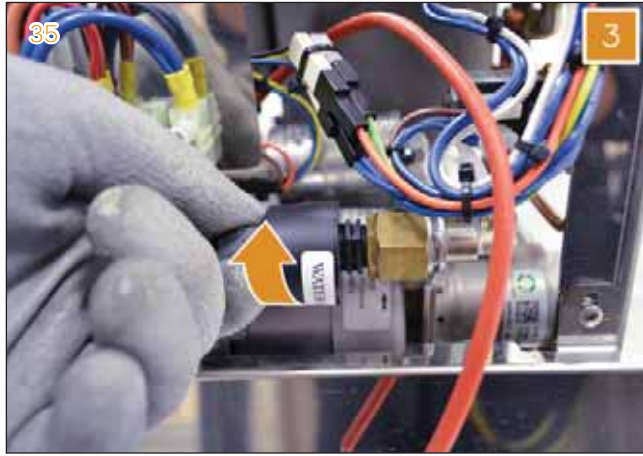

8.5.2 REMOVAL OF THE STEAM BOILER PRESSURE TRANSDUCER

The steam boiler pressure transducer is placed on the front of the machine, over the pressure gauge.

To remove it, proceed as it follows:

- 1 Remove the cup holder surface, the side panels, the drip tray and the lower front panel, as described in chapter 3.

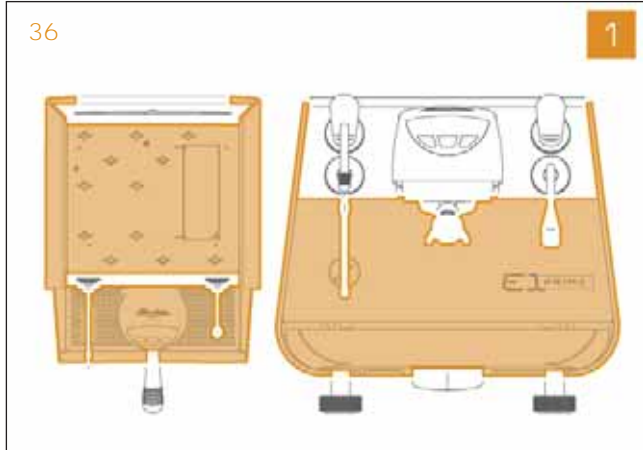

- 2 Unplug the connector.



- 3 Unscrew and remove the pressure transducer by hand.



8.6 GROUP COVER AND SERVICE BOARD

The coffee group has a cover, where the service board is installed.

To access it, remove the group cover as described in paragraph 3.6.

The service board includes, on the front side:

- A The ghost display
- B The 3-buttons keypad

On the rear side:

- C The connection for steam / Easycream service
- D The connection for hot water service
- E The connection for the control unit
- F The DIP switch (under the small cover)

The DIP switch is accessible by removing its small cover (F). Its setting permits to the control unit to correctly identify the service board.

The DIP switch configuration is mandatory: the sequence is OFF - OFF, ON - OFF, and it is shown in the picture.

WARNING

When a service board is replaced, it is suggestable to check its DIP switch configuration.

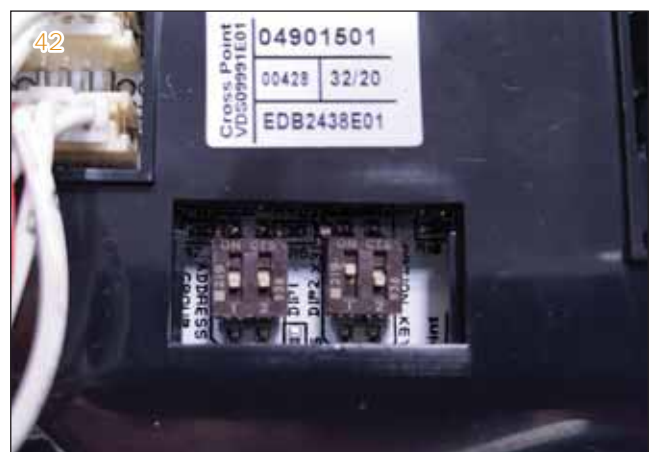
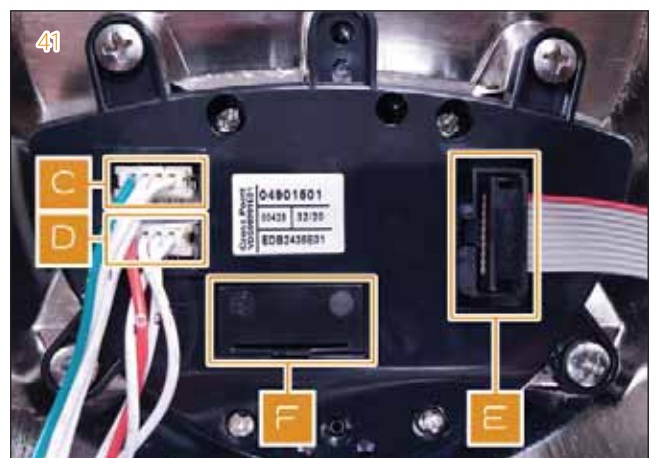
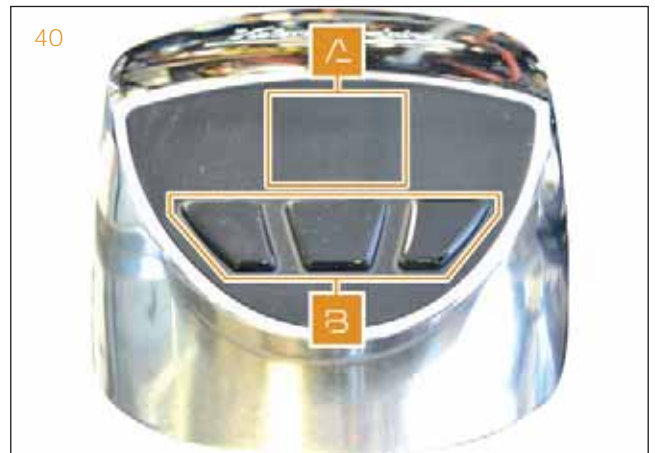
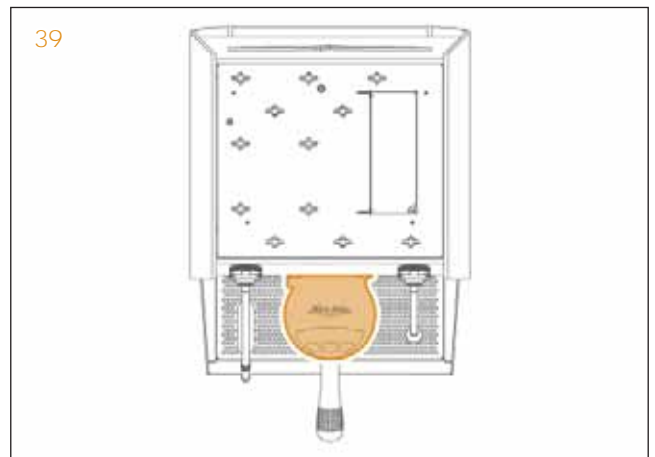

NOTE

It is possible to check the functioning of all segments and icons of the ghost display. Press and hold together the 3-buttons of the keypad.

NOTE

Hold the 3-buttons for a maximum of 2 seconds, otherwise the EMPTY BOILER procedure will start, as explained in paragraph 9.4.2.

PROBLEMS

Possible issues on the service board are:

- 1 One or more segments of the ghost display does not work: replace the service board.
- 2 One or more keys do not work anymore: replacement due to wear.
- 3 All keys do not work anymore: check the flat cable or replace the service board.

REPLACEMENT

Once the group cover has been removed, unscrew the four screws keeping the service board and take it away.



8.7 SERVICE KNOB

Steam / Easycream and hot water wands have their knob to start their service. It is possible to push the knob up and down, to have two different doses, in accord with the programming.

If any knob is not working, check the cabling or replace it, as it follows:

1 Remove the cup holder surface, as described in Chapter 3.

2 Disconnect the cabling.

3 Utilizing a 3 mm Allen key, remove the 2 screws to replace the whole knob assembly.

4 Utilizing a 2,5 mm Allen key, remove the 4 screws to replace only the knob board.

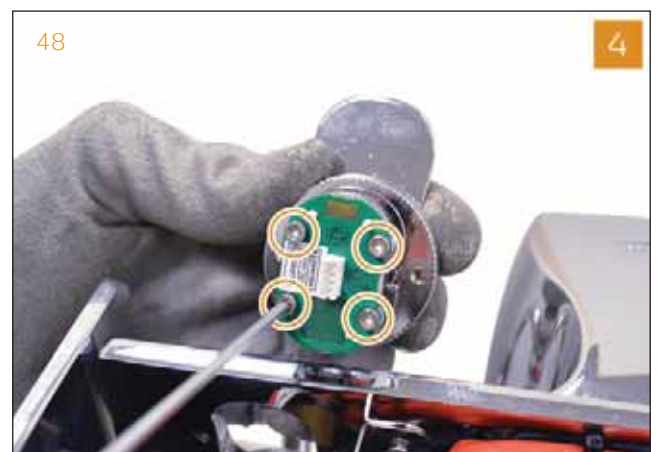

8.8 WATER TANK PRESENCE SENSOR

The water tank presence sensor is a capacitive sensor that recognises the presence of water in the tank.

If it does not work, check its connection and replace it if needed.

Proceed like it follows:

1 Remove the cup holder surface and the water tank, as described in Chapter 3.

2 Utilizing a Philips screwdriver, remove the 4 screws of the water tank support.

3 Extract the water tank support and place it on the machine.

4 Utilizing a 5,5 mm wrench, remove the four nuts fixing the sensor cover and open it.

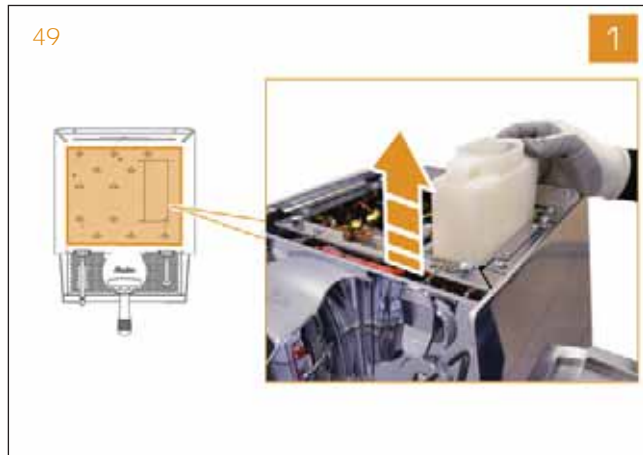

5 Disconnect the cabling.

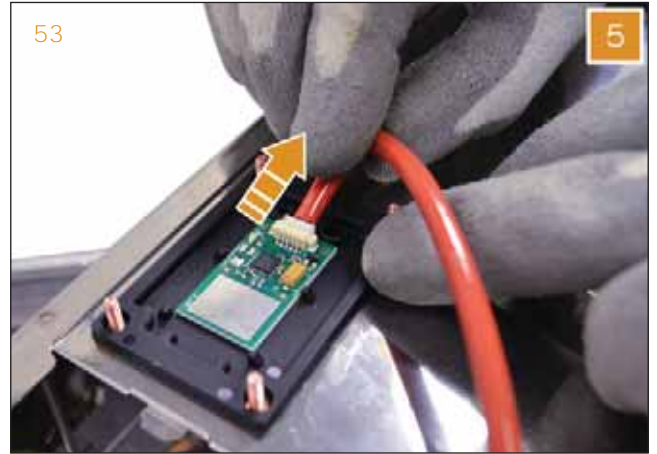

8.9 LIGHTS

The **EI PRIMA** is equipped with lights: a LED on each side of the coffee group and a LED bar on the back side of the machine. All lights are connected with the same cabling in parallel to the control unit.

In case of needs, to replace the group LED, proceed as it follows:

- 1 Remove the group cover, as described in chapter 3. Utilizing plier or by hand, disconnect the cabling.
- 2 Utilizing a small flat screwdriver, press the three little wings and push down the led.

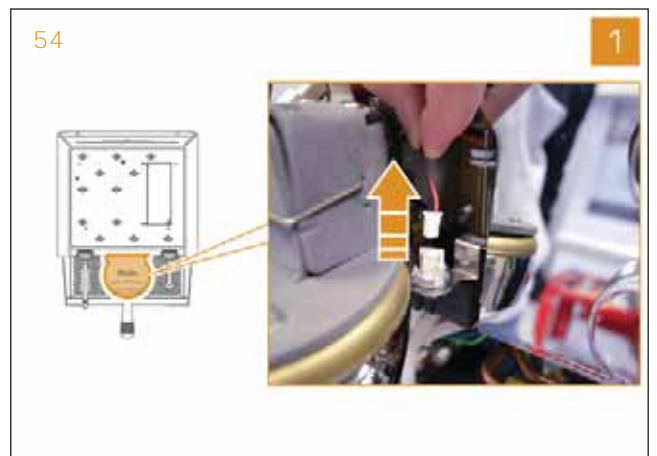

To replace the LED bar on the back side, proceed as it follows:

1 Remove the rear panel, as described in chapter 3.

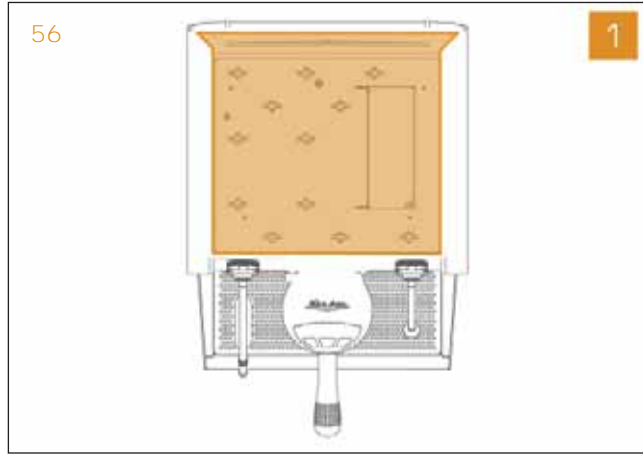

2 Cut the clamp of the wire.



3 Utilizing a 5,5 mm wrench, remove the two nuts fixing the bar.

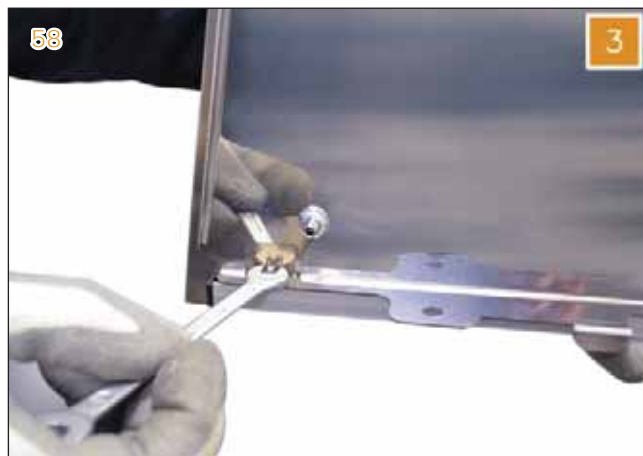

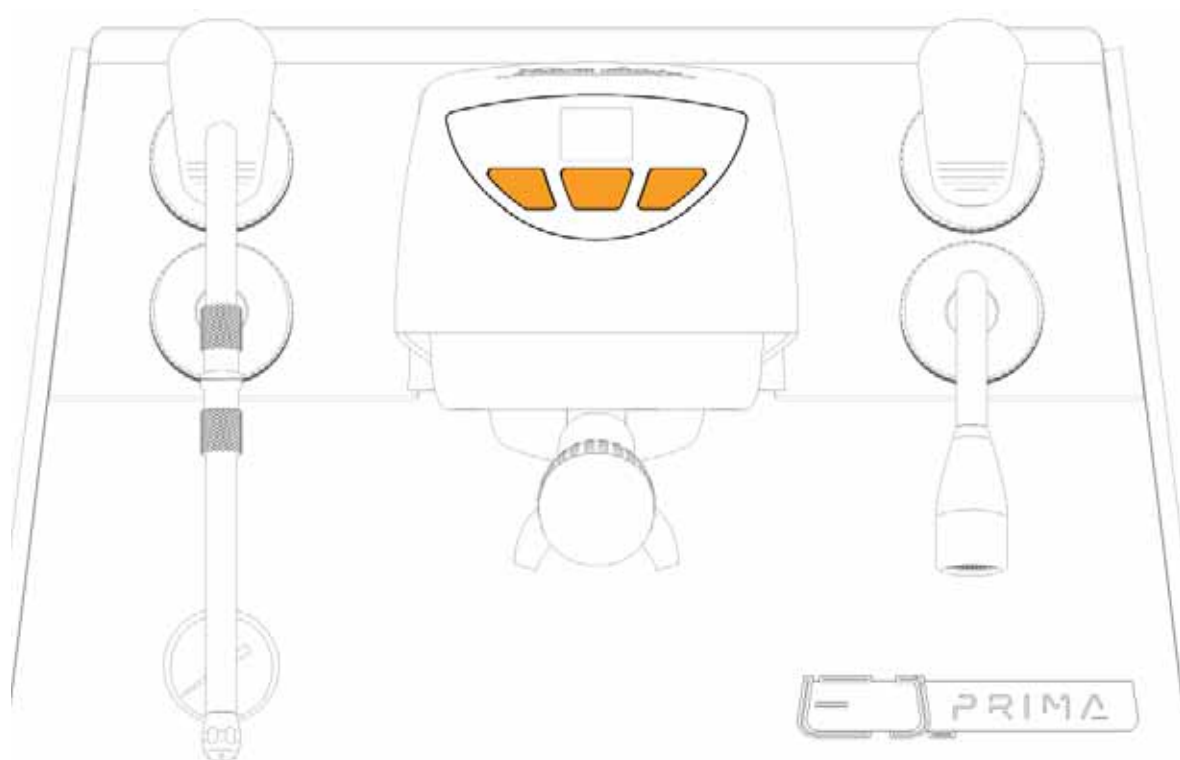

INDEX

09	PROGRAMMING	141
9.1	BASIC FUNCTIONS	142
9.1.1	MACHINE ON/OFF	142
9.1.2	STAND-BY	142
9.1.3	SWITCHING FROM TANK TO DIRECT CONNECTION	143
9.1.4	SWITCHING FROM DIRECT CONNECTION TO TANK	143
9.2	PROGRAMMING	144
9.2.1	COFFEE TEMPERATURE	145
9.2.2	COFFEE DOSES	146
9.2.3	HOT WATER DOSES	148
9.2.4	EASYCREAM TEMPERATURE (OPTIONAL)	150
9.3	CLEANING PROCEDURE	151
9.4	SPECIAL FUNCTIONS	155
9.4.1	GHOST DISPLAY VERIFICATION PROCEDURE	155
9.4.2	EMPTY BOILER PROCEDURE	155
9.4.3	FILLING PROCEDURE	156
9.4.4	RESET COUNTERS PROCEDURE	157
9.4.5	RESET PARAMETERS PROCEDURE	158
9.5	MACHINE UPDATE	160

NOTE

Please note that the programming could vary from certain firmware release on. This Service Manual is based on firmware release v32.

The group buttons and icons are identified as **1A**, **1B**, **1C**, **T** and **H**, as shown in the picture.

- T** Tank icon
- G** Ghost display
- H** Heating icon

- 1A** Coffee delivery button dose 1
- 1B** Continuous coffee delivery button
- 1C** Coffee delivery button dose 2

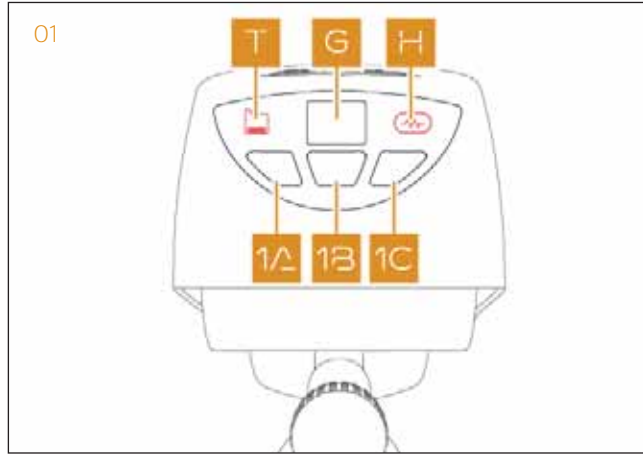

09 9.1 BASIC FUNCTIONS

9.1.1 MACHINE ON/OFF

Press the ON/OFF switch found on the bottom right of the device.



9.1.2 STAND-BY

Press and hold the **1B** for 5 seconds to activate the machine from standby mode.

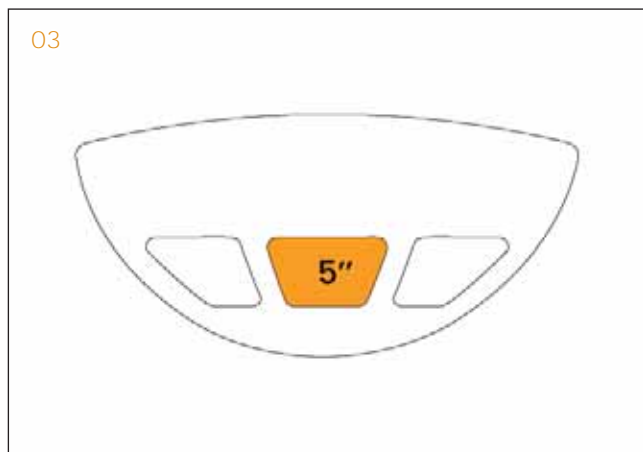

9.1.3 SWITCHING FROM TANK TO DIRECT CONNECTION

To switch from tank to direct connection, proceed as it follows:

1 Turn OFF the machine using the main switch.

2 Press and hold the **1A** and **1C** buttons while turning the machine ON using the main switch. The **T** icon will blink 3 times and then go out (signalling that the change has been completed successfully).

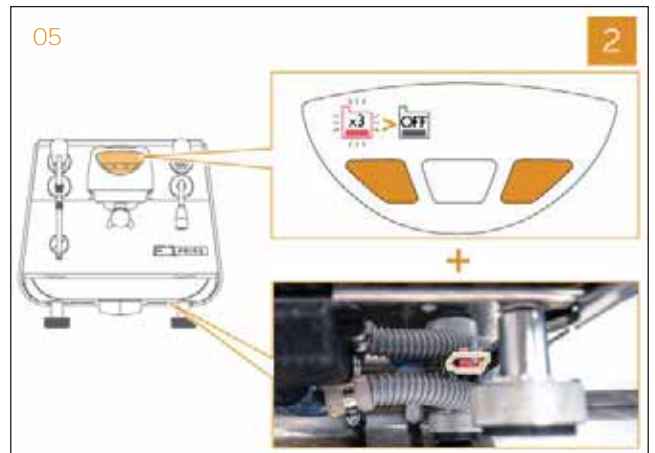
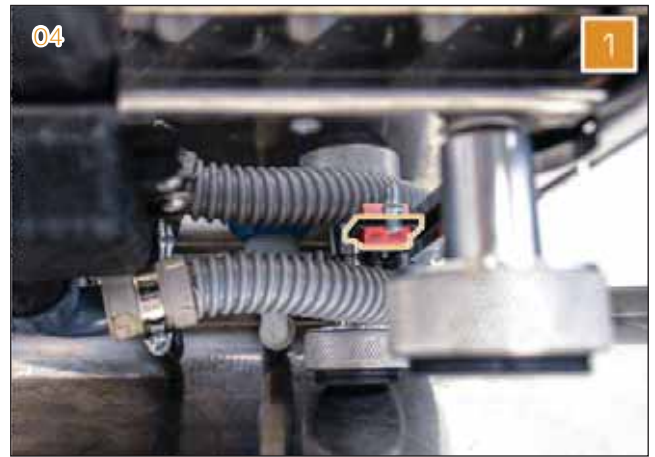

9.1.4 SWITCHING FROM DIRECT CONNECTION TO TANK

To switch from direct connection to tank, proceed as it follows:

1 Turn OFF the machine using the main switch.

2 Press and hold the **1A** and **1C** buttons while turning the machine ON using the main switch. The **T** icon will blink 3 times and then remain steady for a few seconds (indicating that the change has been completed successfully).

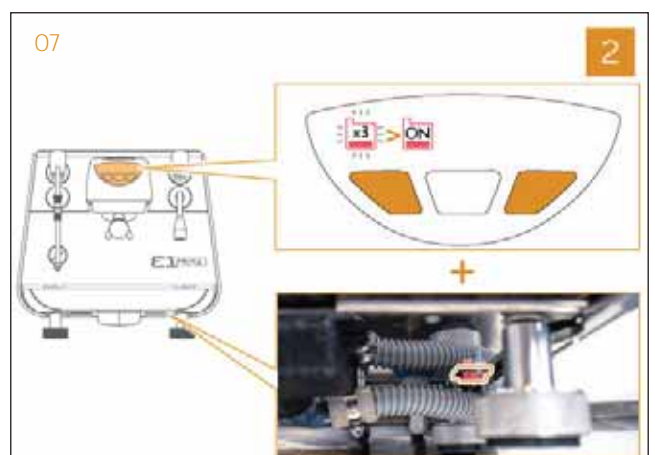

9.2 PROGRAMMING

The **EI PRIMA** is completely programmable by the **Victoria Arduino APP**, which can be downloaded from the ANDROID/IOS store respectively.



09

A basic programming is also possible from the keyboard on the machine with the group buttons (**1A**, **1B**, **1C**) and will be explained in the next paragraphs.

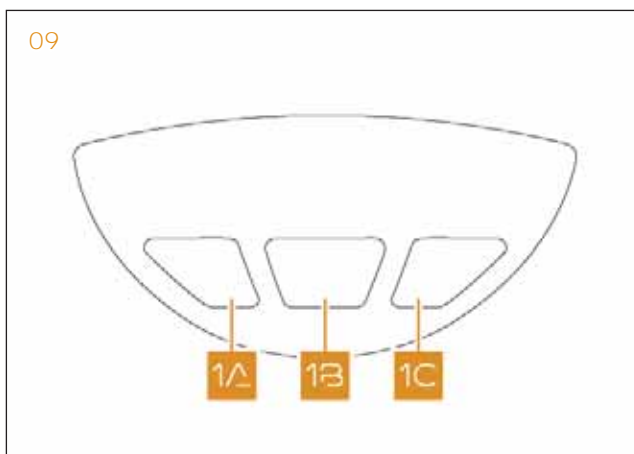

9.2.1 COFFEE TEMPERATURE

To program coffee temperature, proceed as it follows:

1 Press and hold the **1A** and **1C** buttons for 5 seconds, to enter the first level programming menu.

2 Access is confirmed when the **1B** button starts blinking and the set temperature is shown on the display.

3 Press the **1A** and **1C** buttons to decrease or increase the temperature. Display will show the set temperature.

4 To store, confirm and exit, press the **1B** button for 3 times.

NOTE

It is also possible to set the half degree (which can be viewed from the subscript shown on the display).

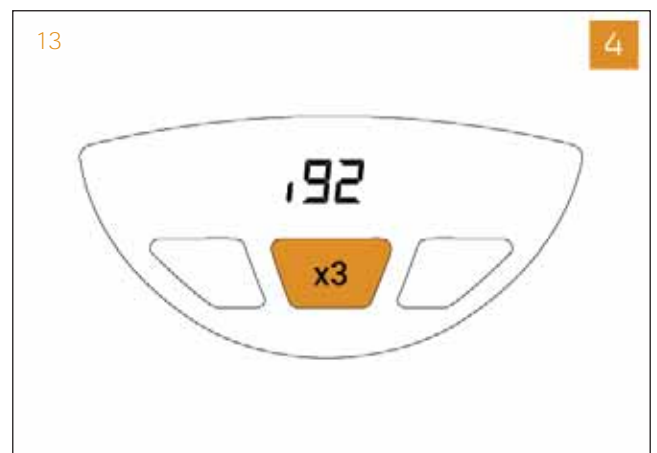
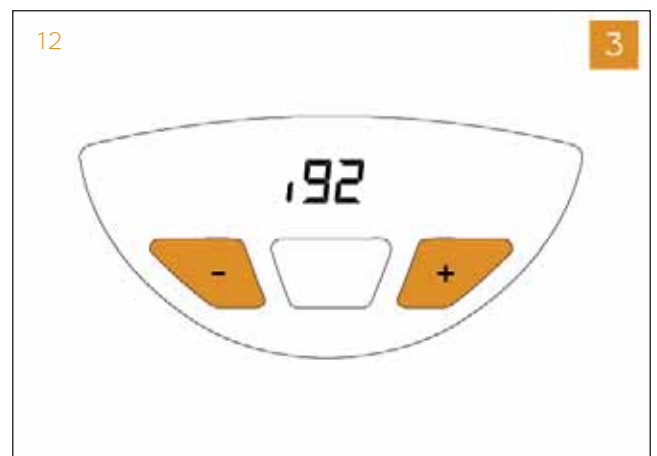
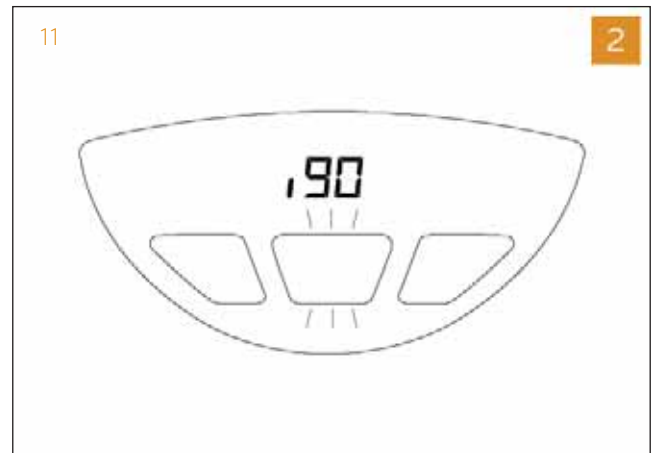
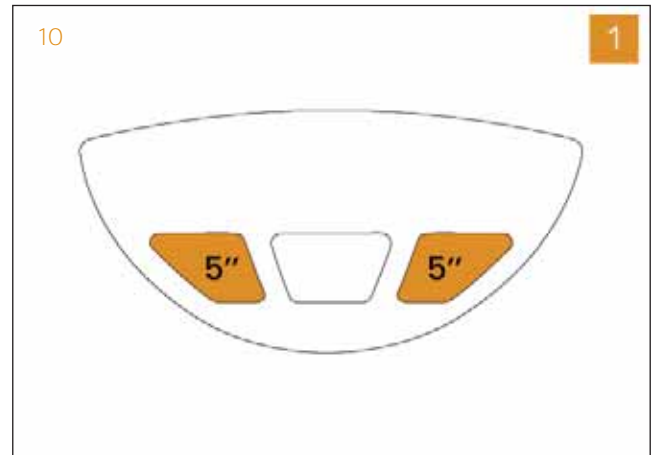

9.2.2 COFFEE DOSES

To program coffee doses, proceed as it follows:

1 Press and hold the **1A** and **1C** buttons for 5 seconds, to enter the first level programming menu.

2 Access is confirmed when the **1B** button starts blinking and the set temperature is shown on the display.

3 Press the **1B** button to enter the second level programming menu.

4 Access is confirmed when the message "dS" is shown on the display and the **1B** button starts blinking.

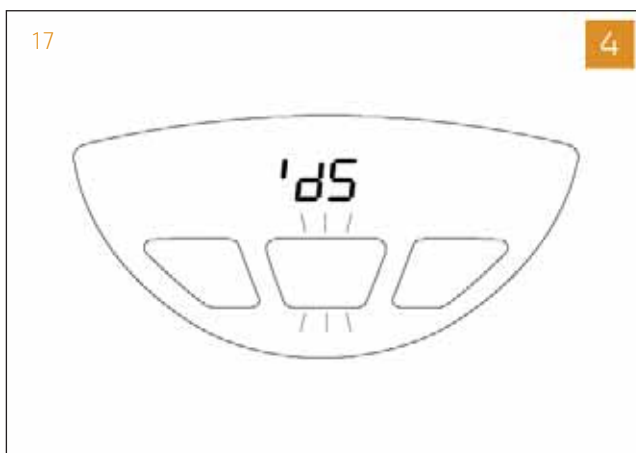
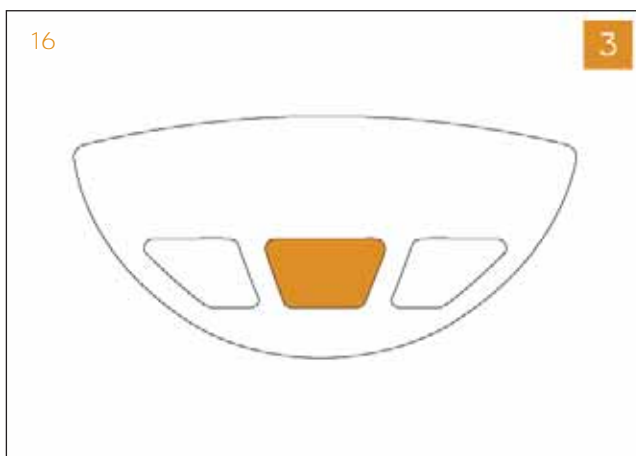
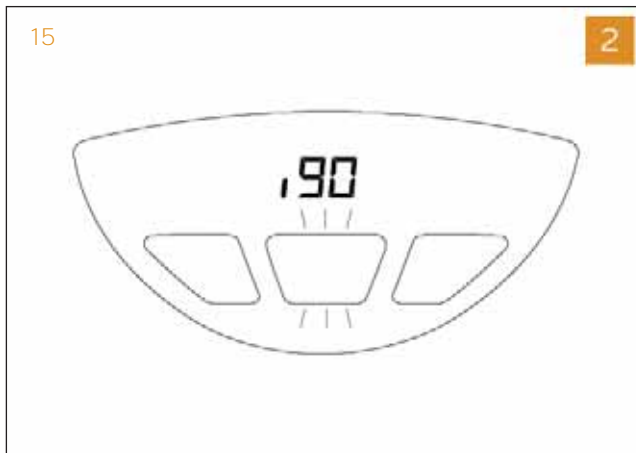
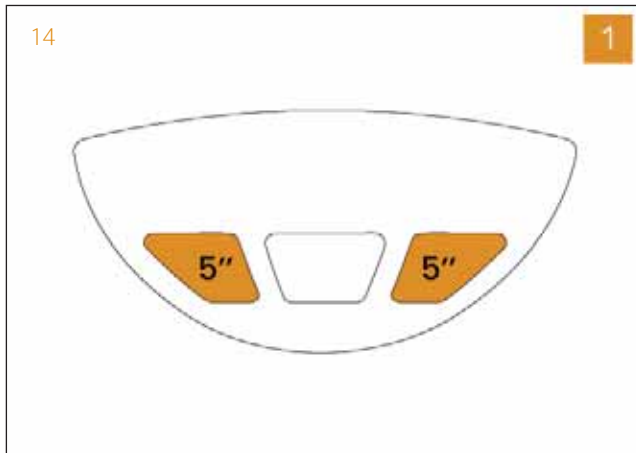

5 Press the desired coffee button to initiate delivery.

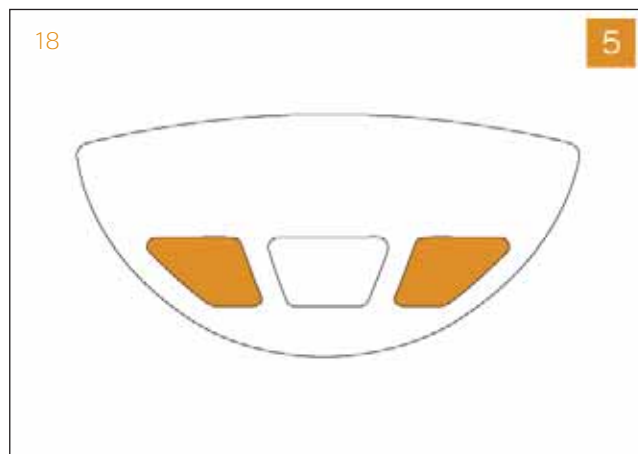

6 The pressed button remains lit and the delivery time (in seconds) is shown on the display.

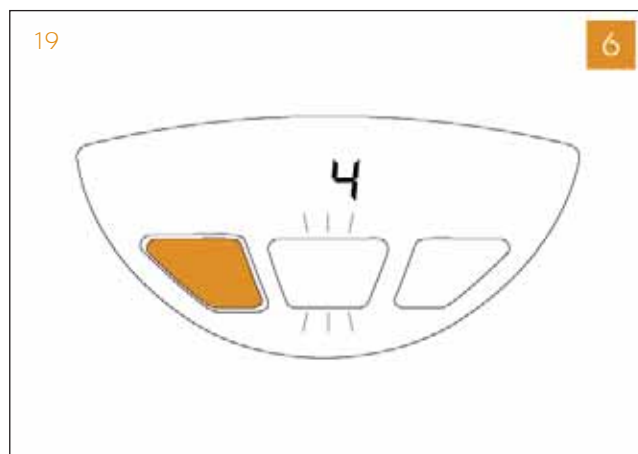

7 Press the coffee button again to stop delivery and store the dose in the memory.

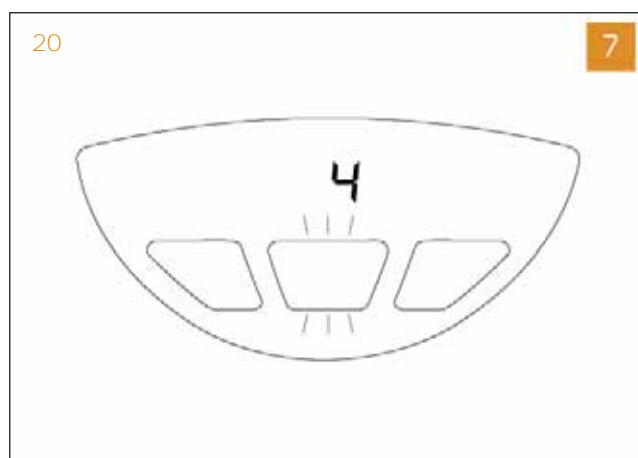

8 To confirm and exit, press the **1B** button twice.

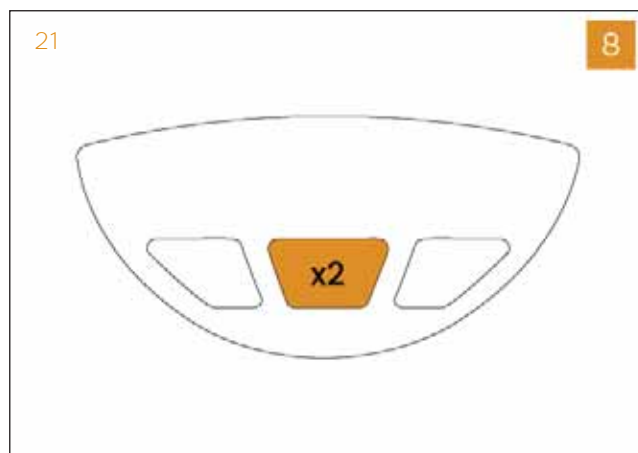

09

9.2.3 HOT WATER DOSES

To program the final hot water temperature, proceed as follows:

1 Press and hold the **1A** and **1C** buttons for 5 seconds, to enter the first level programming menu.

2 Access is confirmed when the **1B** button starts blinking and the set temperature is shown on the display.

3 Press the **1B** button to enter the second level programming menu.

4 Access is confirmed when the message "dS" is shown on the display and the **1B** button starts blinking.

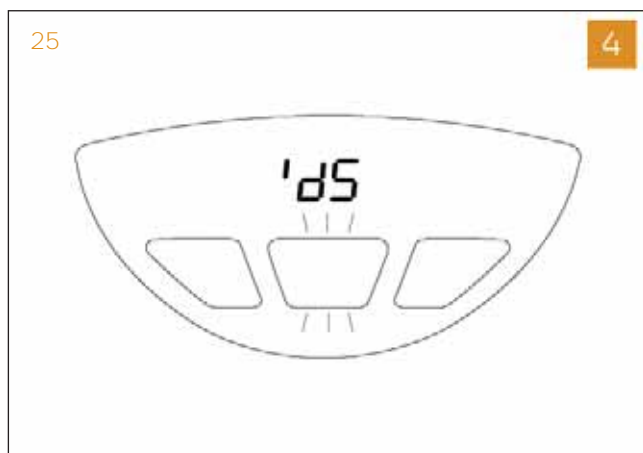
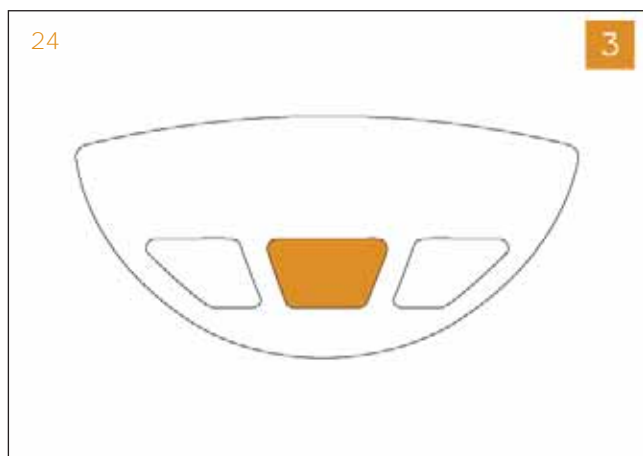
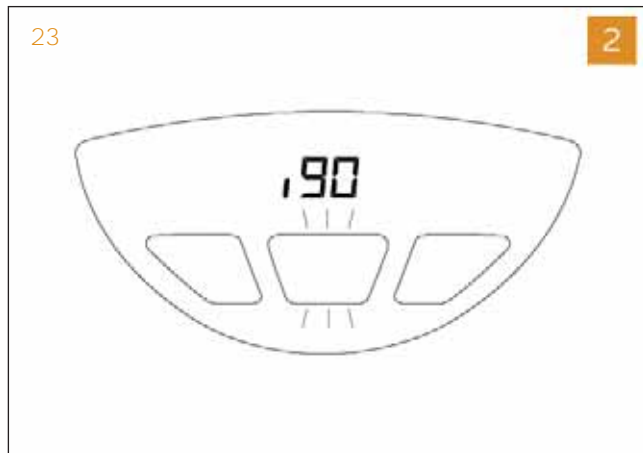
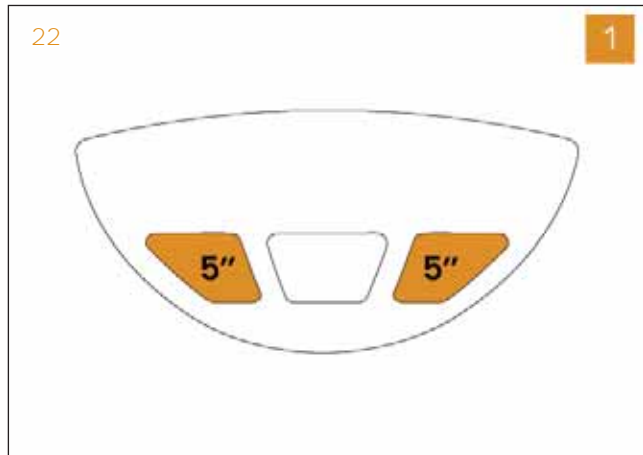

- 5 Programming takes place by operating the lever. Push the upper part of the lever to programme the first dose of hot water "**key 1**". Push the lower part of the lever to programme the second dose of hot water "**key 2**".

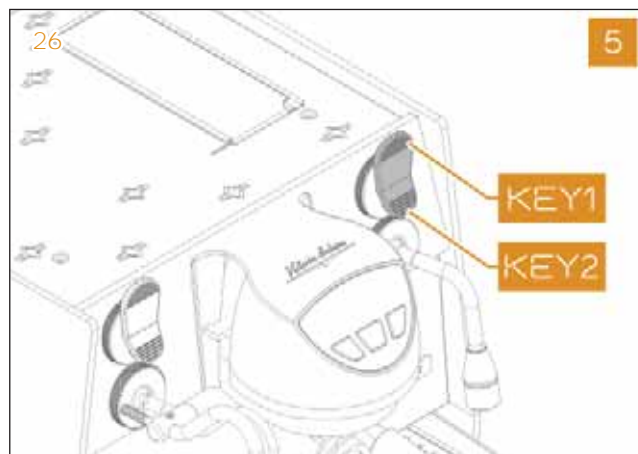

- 6 Push the lever again to stop delivery and store the dose in the memory.

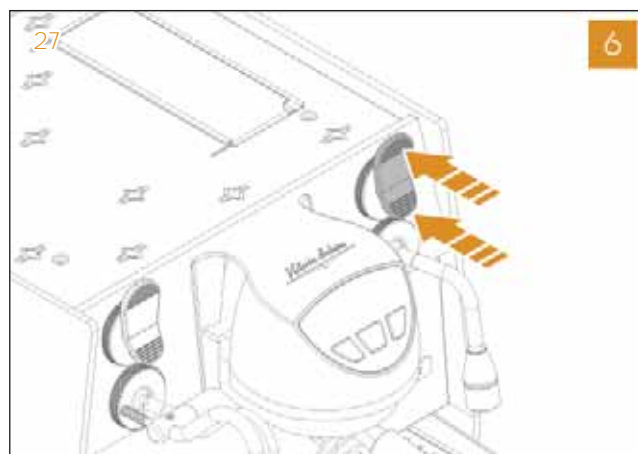

- 7 To confirm and exit, press the **IB** button twice.

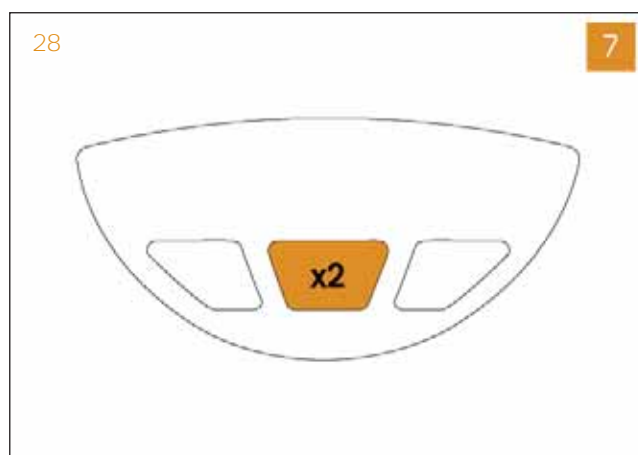

9.2.4 EASYCREAM TEMPERATURE (OPTIONAL)

To program the Easycream final temperature:

1 Press and hold the **1A** and **1C** buttons for 5 seconds, to enter the first level programming menu.

2 Access is confirmed when the **1B** button starts blinking and the set temperature is shown on the display.

3 Press the **1B** button to enter the second level programming menu.

4 Access is confirmed when the message "dS" is shown on the display and the **1B** button starts blinking.

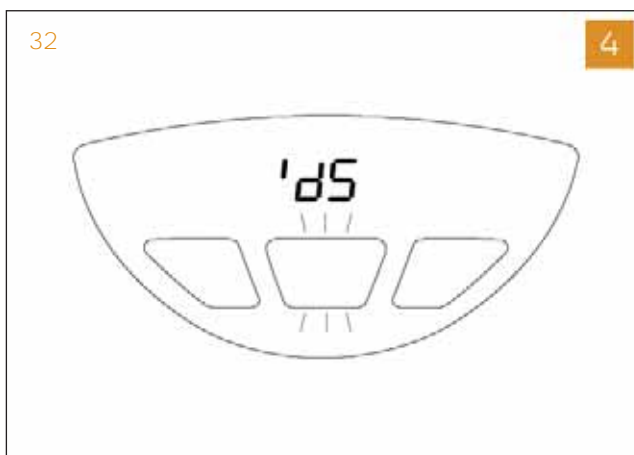
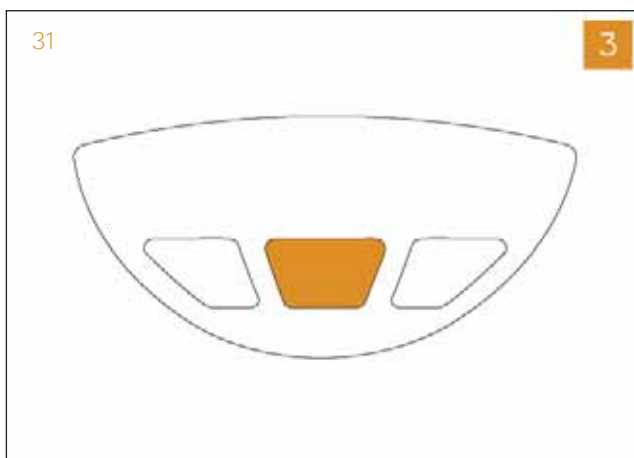
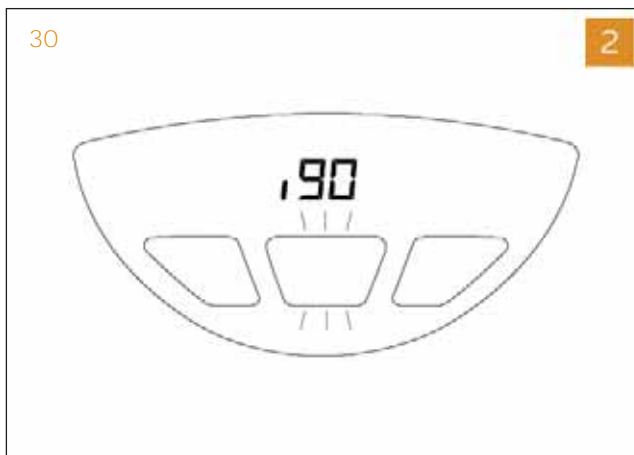
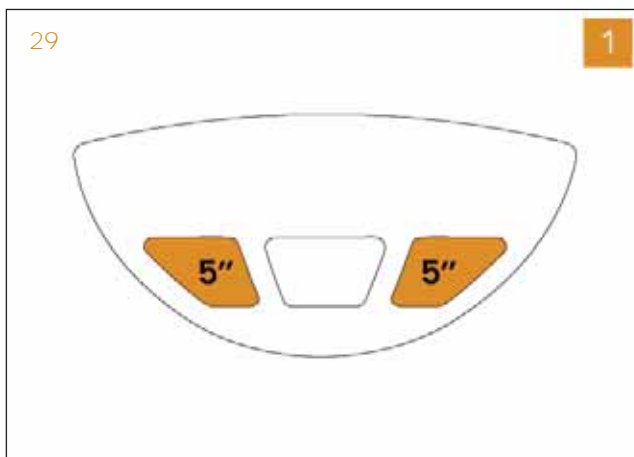

5 Programming takes place by operating the lever. Push the upper part of the lever to enter the final temperature programming of the first Easycream recipe "**key 1**". Push the lower part of the lever to enter the final temperature programming of the second Easycream recipe "**key 2**".

6 Decrease or increase the temperature by pressing the **1A** and **1C** buttons respectively; the temperature is shown on the unit display.

NOTE

It is also possible to set the half degree (which can be viewed from the subscript shown on the display).

7 To store, confirm and exit, press the **1B** button twice.

9.3 CLEANING PROCEDURE

The machine's dispensing group may be washed with an automatic cleaning cycle and specific powder detergent. Wash at least once a day.

To carry out the cleaning procedure, proceed as it follows:

1 If the machine is set to the **tank version**, fill the tank, otherwise proceed directly to point 2.

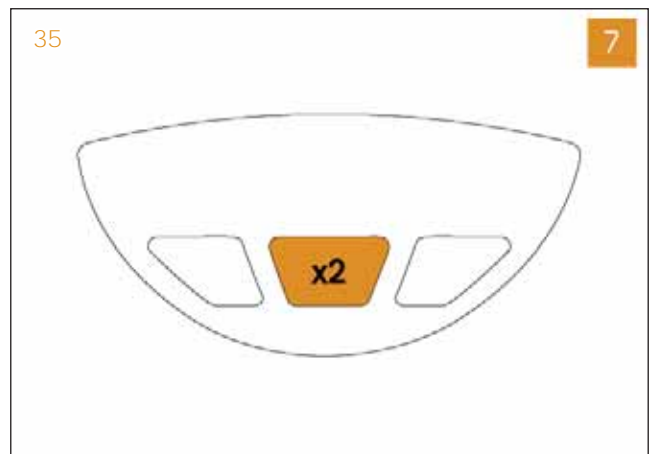
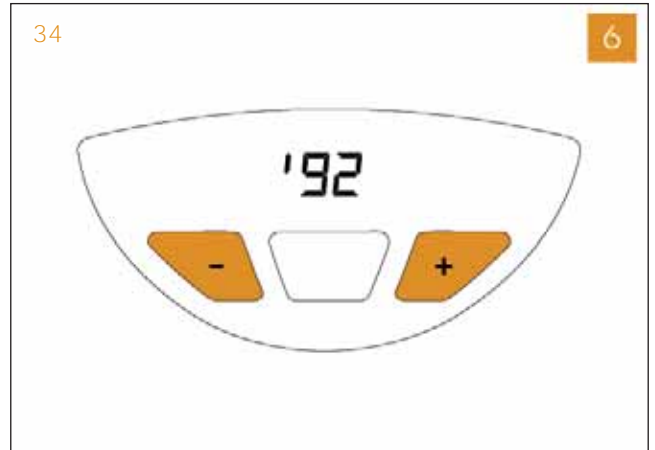
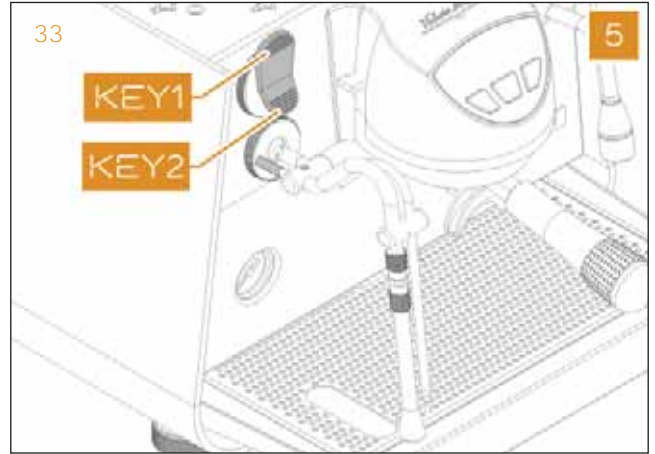

2 Replace the filter in the filter holder with a blind filter.

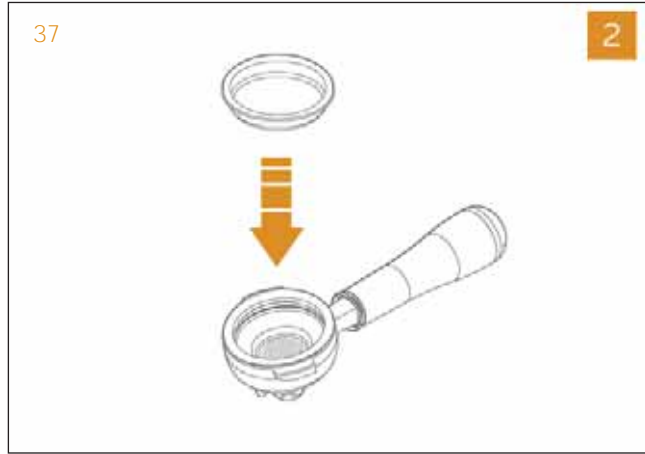

3 Place the manufacturer's recommended dose of specific powder detergent inside and put the filter holder into the group.

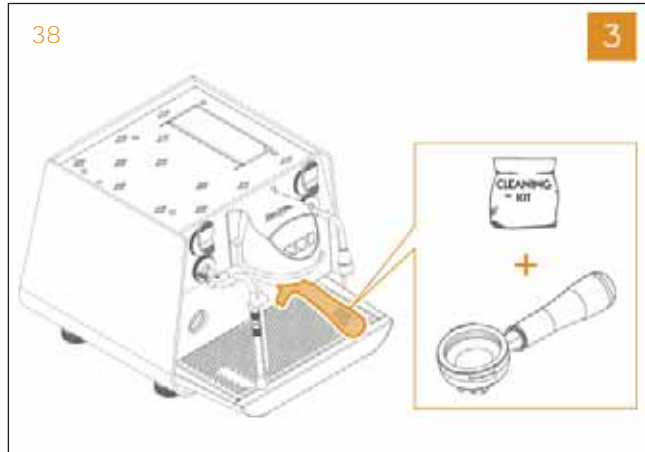

4 Press and hold the **1A** and **1C** buttons for 5 seconds to enter the first level programming menu.

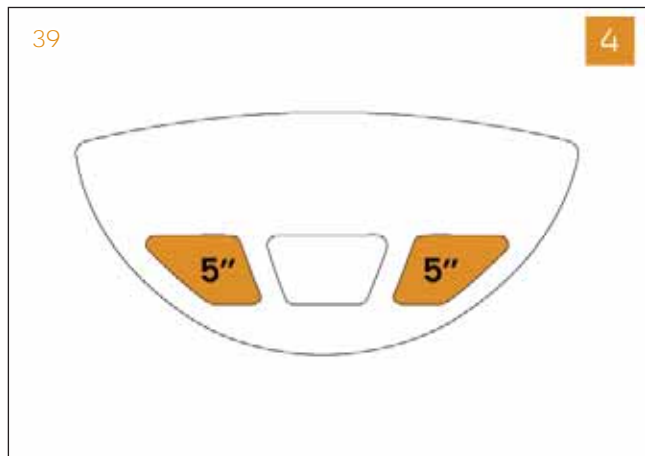

5 Access is confirmed when the **1B** button starts blinking and the set temperature is shown on the display.

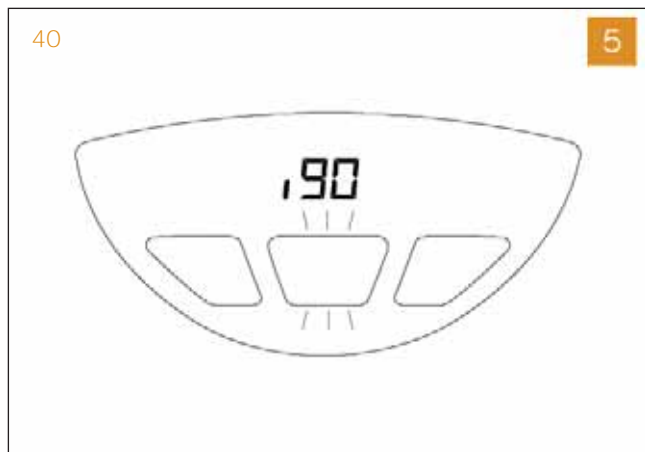

09

6 Press the **1B** button to enter the second level programming menu.

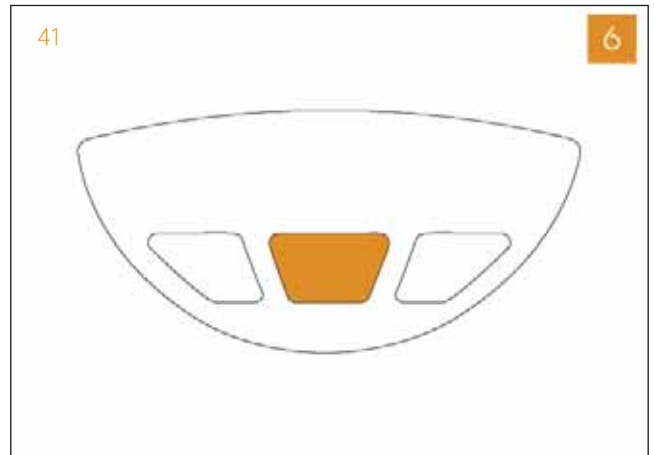

7 Access is confirmed when the message "dS" is shown on the display and the **1B** button flashes.

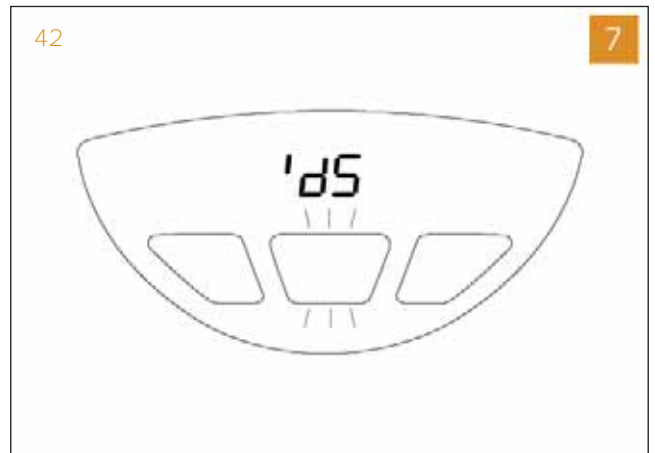

8 Press the **1B** button to enter the third level programming menu.

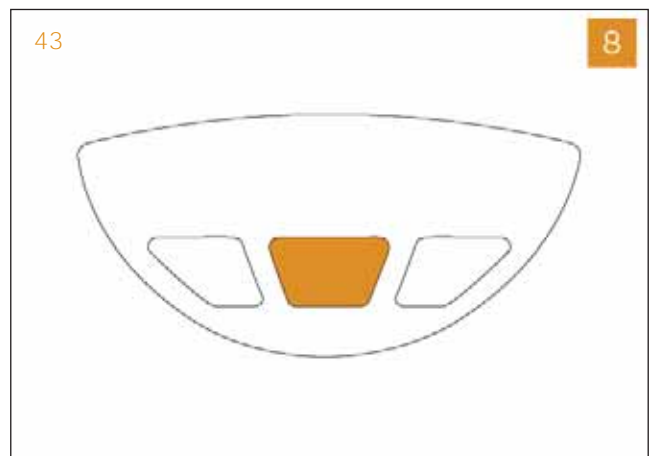

9 Access is confirmed when the message "cL" is shown on the display, the **1B** button flashes and the **1C** button is steady ON.

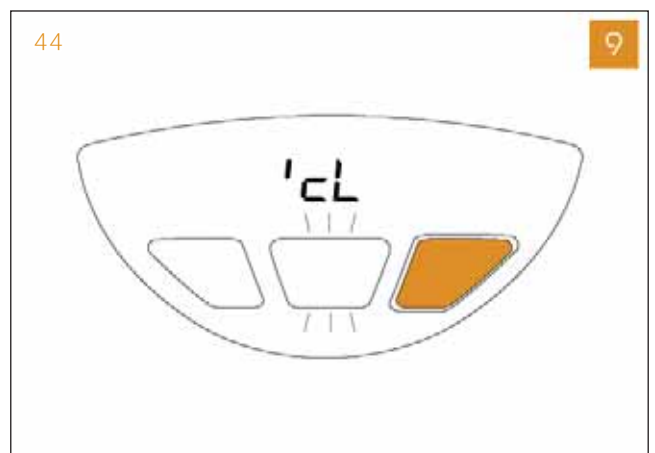

NOTE

The programming menu closes if the **1B** button is pressed again. The menu automatically closes if not used within 15 seconds.

10 Press the **IC** button to start the wash cycle; the button flashes rapidly.

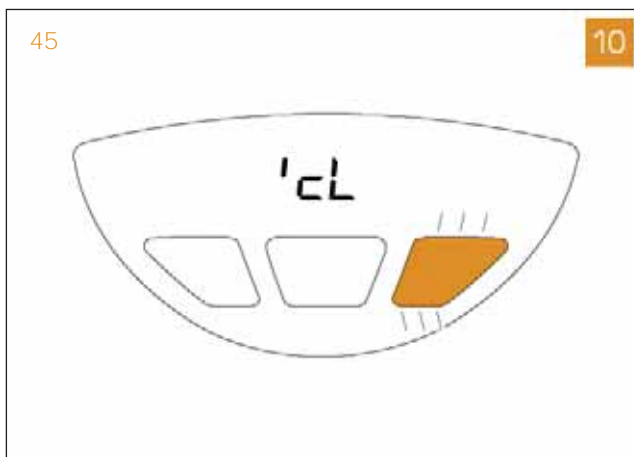

11 Once the washing phase is complete, the machine stops and the **IC** button remains ON.

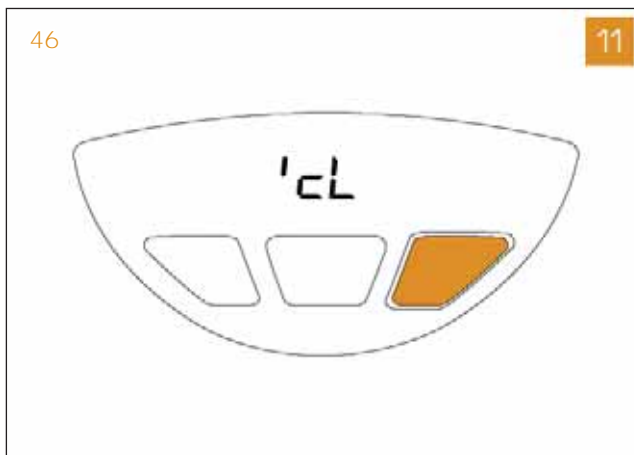

NOTE

Before rinsing, remove any residual detergent remaining in the filter holder.

12 Press the **IC** button to start the rinse phase; the button flashes more slowly.

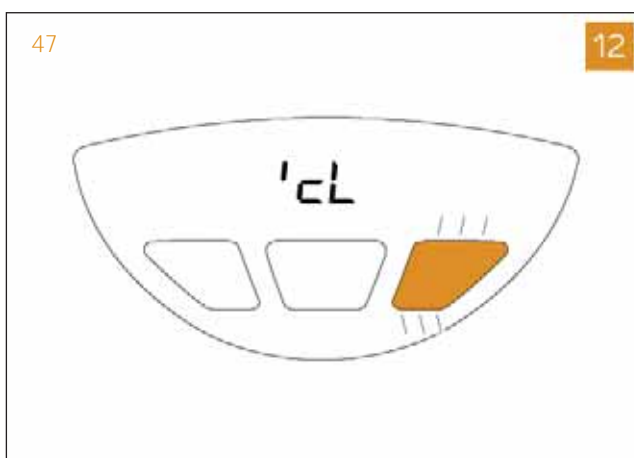

13 When the procedure is complete, replace the blind filter with the normal filter and continue with normal operation.

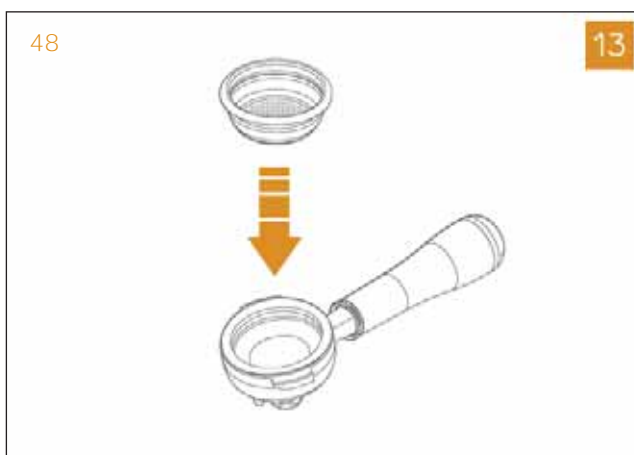

9.4 SPECIAL FUNCTIONS

9.4.1 GHOST DISPLAY VERIFICATION PROCEDURE

To verify the correct functioning of all the segments and icons of the ghost display, proceed as it follows:

1 Press and hold together the **1A**, **1B** and **1C** buttons.

2 The number **188**, **T** and **H** icons should appear on the display.

NOTE

Hold the 3-buttons for a maximum of 2 seconds, otherwise the empty boiler procedure will start.

9.4.2 EMPTY BOILER PROCEDURE

The empty boiler procedure stops the heating of the machine and opens the steam valve, the hot water valve and the coffee valve, in order to reduce the pressure in the steam boiler and in the coffee boiler.

Keeping the procedure active for a few minutes permits to completely reduce the pressure.

It is useful when the machine is hot and it is necessary to intervene on steam boiler and/or coffee boiler for technical operations.

To activate the empty boiler procedure, proceed as it follows:

1 Press and hold together the **1A**, **1B** and **1C** buttons for 5 seconds.

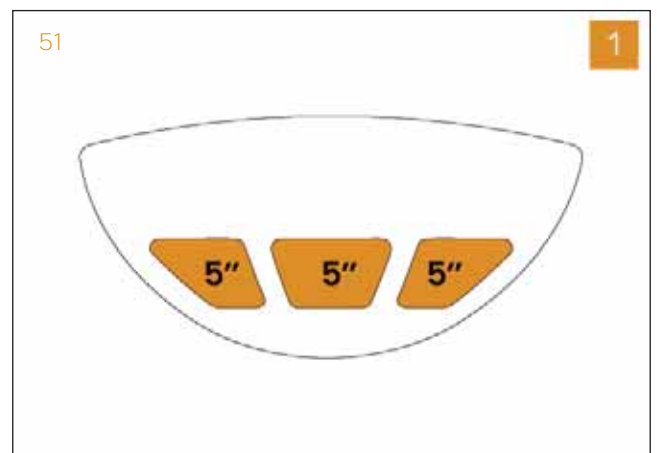
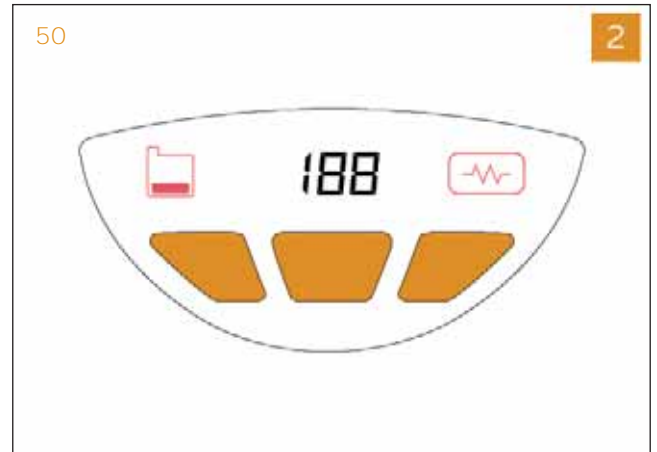
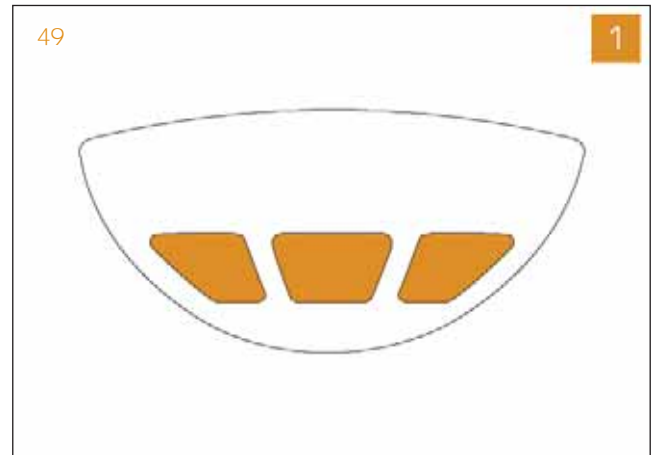

- 2 The **IA**, **IB** and **IC** buttons keypad will be fixed and a 3 seconds countdown will appear on the ghost display. At the end of the countdown, the procedure will automatically starts.

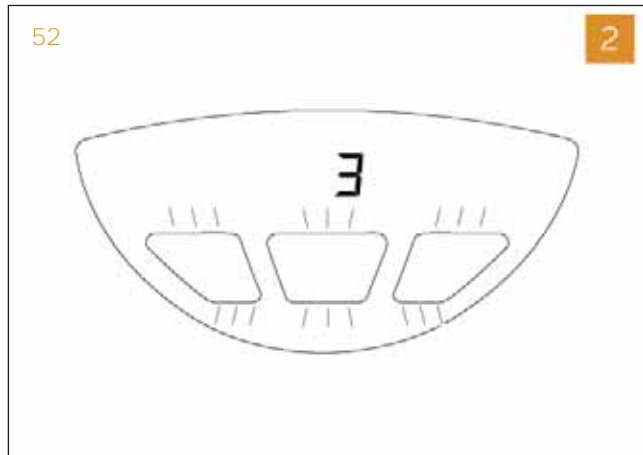

WARNING

Keep attention to the steam and hot water coming out from the machine.



- 3 When the inner pressure has been completely reduced, turn OFF the machine utilizing the main switch.

NOTE

At the end of this procedure, at the next powering ON the machine will be ready to start the FILLING procedure.



9.4.3 FILLING PROCEDURE

The filling procedure is a not-stoppable procedure and permits to fill up the coffee boiler. It is automatically requested at first installation, or after the **EMPTY BOILER** procedure, or after the **RESET PARAMETERS** procedure.

In case it is needed to request it, it's suggestable to perform the **EMPTY BOILER** procedure, as described in the previous paragraph.

The FILLING procedure works like following:

- 1 Switch the machine ON.

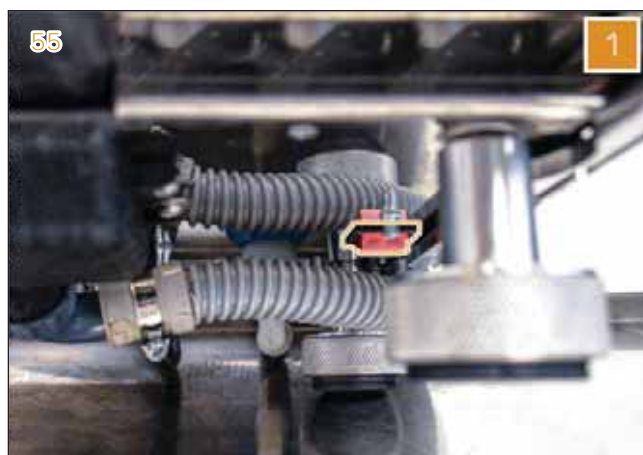

- 2 Writing "FI" appears on the ghost display and the **1A**, **1B** and **1C** buttons flash fast.

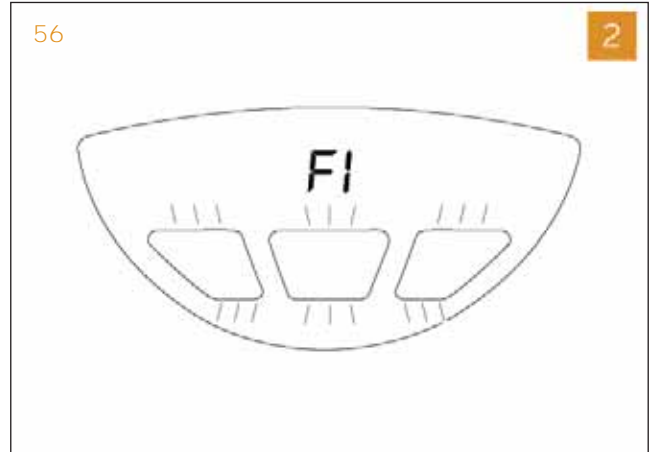

- 3 Wait until the **1A**, **1B** and **1C** buttons flash more slowly.

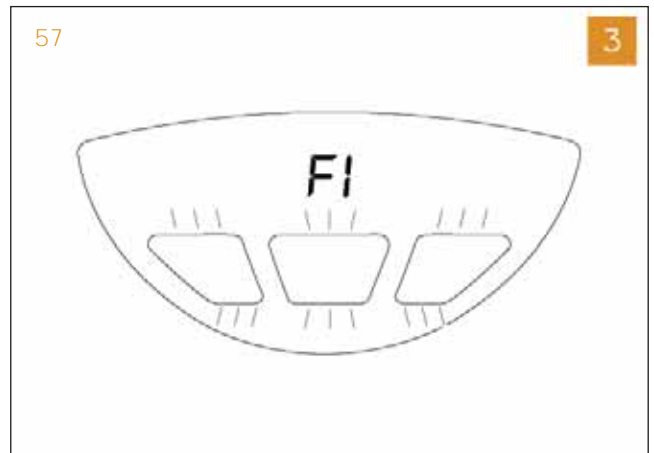

- 4 Press and hold the **1A** and **1C** buttons together until procedure is engaged (the pump starts to run).

NOTE

The machine will pump the water and open the coffee valve for 20 seconds.

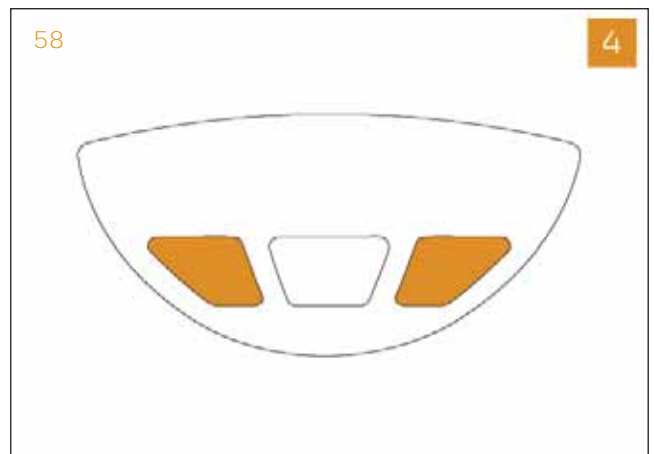

9.4.4 RESET COUNTERS PROCEDURE

To reset all the counters on the machine, proceed as it follows:

- 1 Switch the machine OFF.



- 2 Press and hold the **IB** and **IC** buttons while turning the machine ON using the main switch.

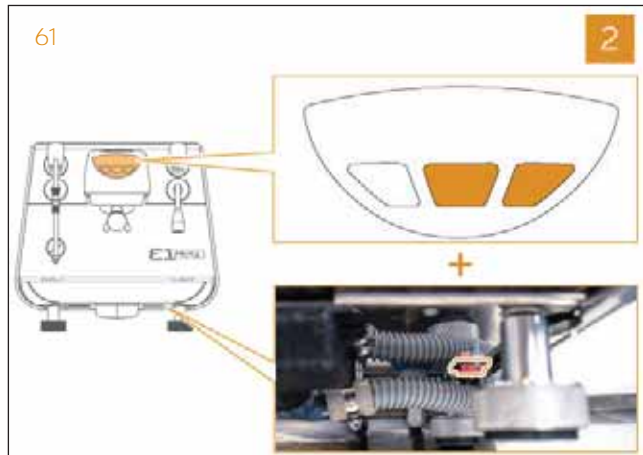

- 3 The writing “**dc**” appears on the ghost display and the **IB** and **IC** buttons flash.

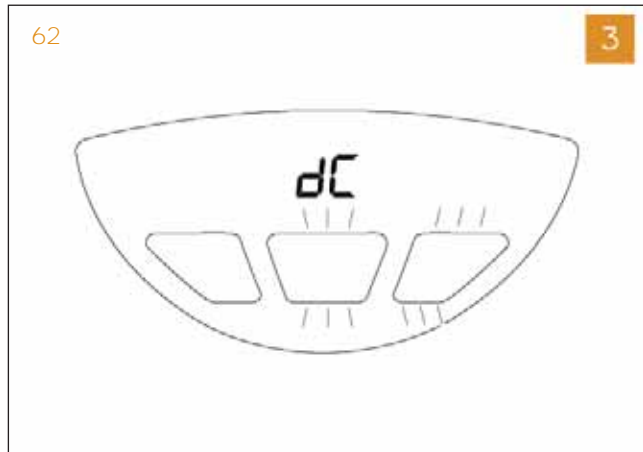

- 4 Switch the machine OFF to record the changings.

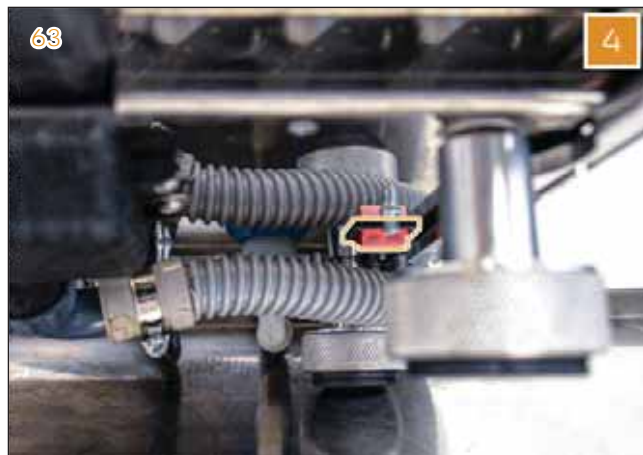

9.4.5 RESET PARAMETERS PROCEDURE

To reset the parameters on the machine, proceed as it follows:

- 1 Switch the machine OFF.



- 2 Press and hold the **1A** and **1B** buttons while turning the machine ON using the main switch.

- 3 The writing **"dP"** appears on the ghost display; the **1A**, **1B** and **1C** buttons are steady ON and the **H** icon flashes.

- 4 Switch the machine OFF to record the changings.

NOTE

With the reset parameters procedure, the machine will return on the default settings: it is ready for the **FILLING** procedure, in tank version. To return to direct connection, follow the procedure explained in paragraph 9.1.3.

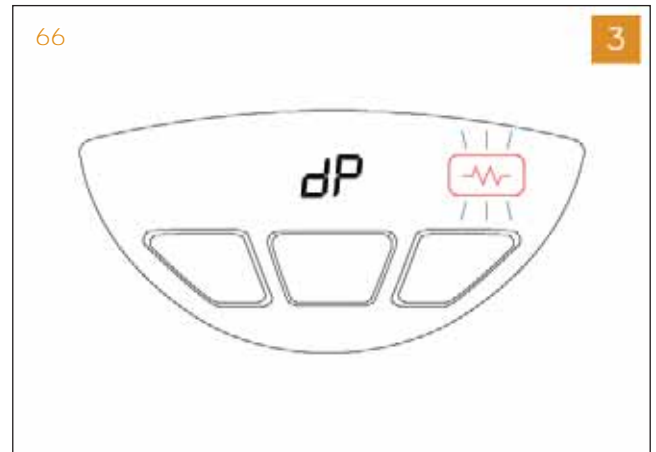
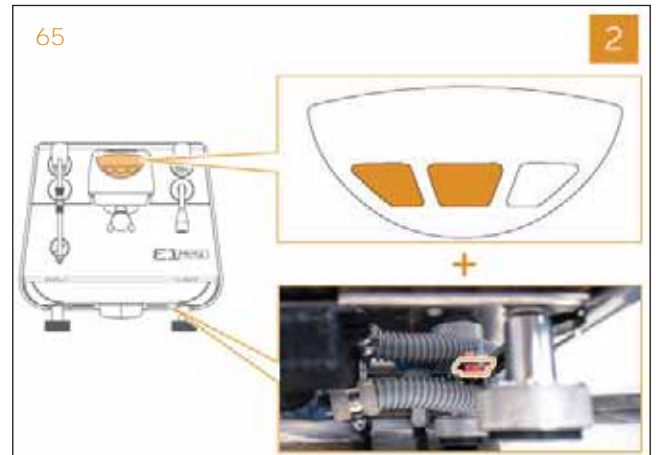

9.5 MACHINE UPDATE

The software version of **EI PRIMA** is only visible in **Victoria Arduino EI APP**.

If an update is needed for any reasons, proceed as it follows:

- 1 Format a USB 1.0 or 2.0 stick as FAT32/4096 bytes.
- 2 Create a folder called “**nuovas**” (one word, all lowercase) and load the file **XXX.hex** to it.

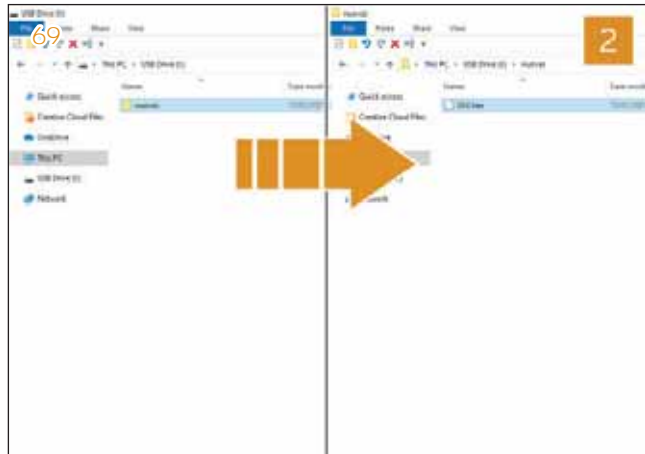
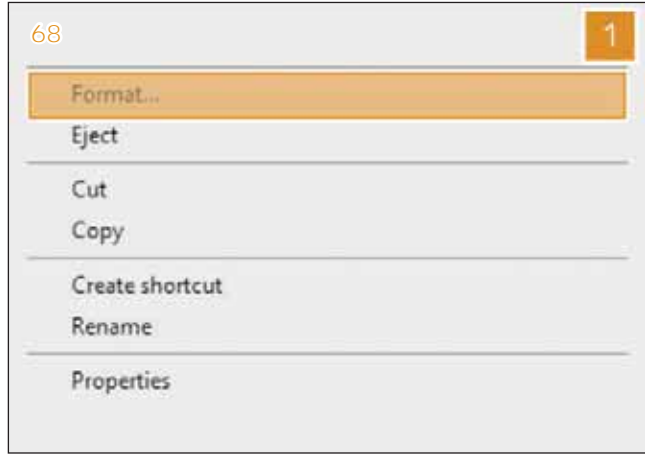

- 3 With the machine switch OFF, insert the USB stick.

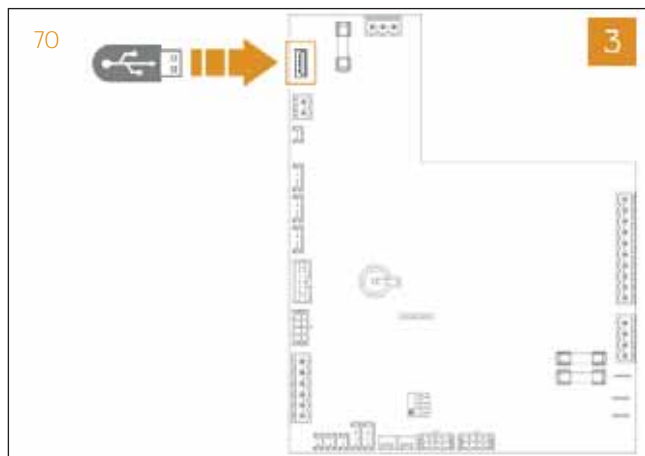

- 4 Switch the machine ON.

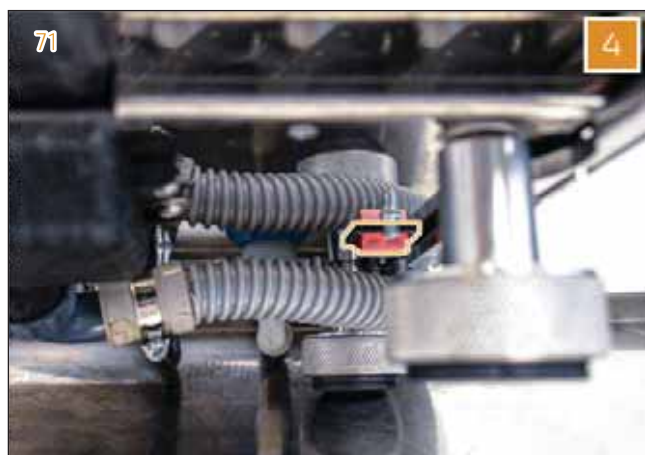

- 5 As the file loads, the rear led bar blinks, the writtens "Pr" and then "US" appear on the group display and the buttons start flashing until the machine returns to Stand-by mode.

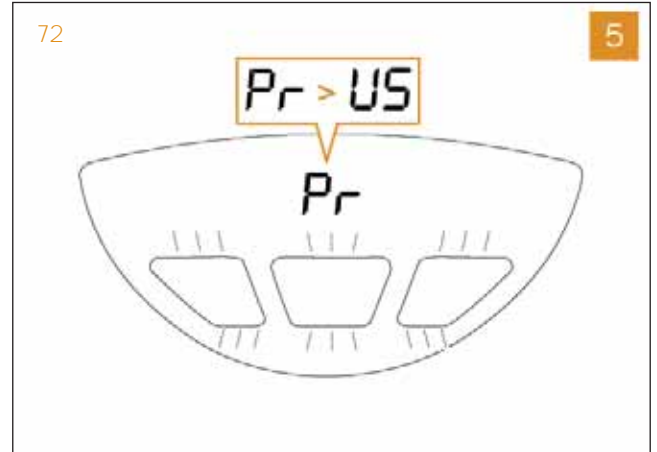

- 6 Switch the machine OFF and remove the USB stick.



- 7 Switch the machine ON and do the **RESET PARAMETERS** procedure as described in paragraph 9.4.5.

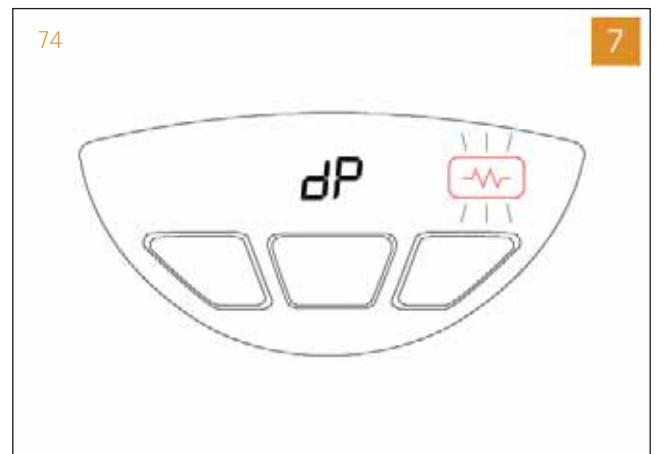

- 8 Switch the machine OFF for 10 seconds and then switch it ON again.





10

ALARMS AND CONTROL OF THE EMERGENCIES



INDEX

10

10	ALARMS AND CONTROL OF THE EMERGENCIES . . .	163
10.1	ALARMS AND SOLUTIONS	164

The **EI PRIMA** can alert the user with various “alarms” on the group display and by keypad and icons signalling.

Below is a Key to decoding the various alarms and signals.

To follow the suggested solutions, if needed, refer to the relative chapters in this manual.

NOTE

Some alarms are significant only from certain firmware release on.

This Service Manual is based on firm-ware release v32.

10.1 ALARMS AND SOLUTIONS

Alarm codes will be seen in the group display, as shown in the picture.

NOTE

To reference keypad and icons signalling, the group buttons and icons are identified as shown in the picture.

- T Tank icon
- G Ghost display
- H Heating icon

- 1A Coffee delivery button dose 1
- 1B Continuous coffee delivery button
- 1C Coffee delivery button dose 2

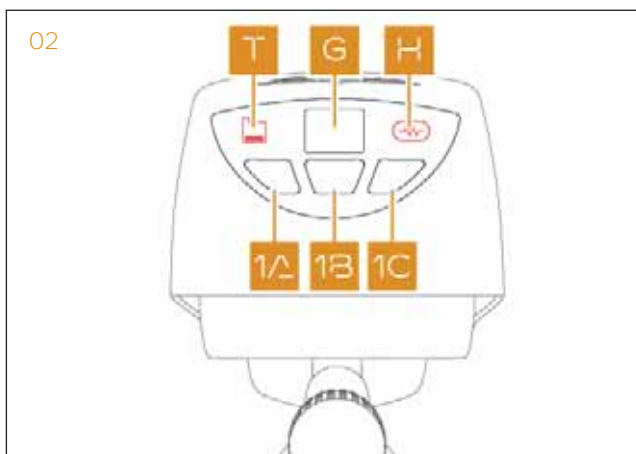

ALARM	MAIN REASON	KEYPAD SIGNALLING	SOLUTIONS
A2	The machine cannot fill the steam boiler within 90 seconds.	Key 1B and icon T flashing.	Switch the machine OFF and ON to restart the auto-fill function. If not solved: <ul style="list-style-type: none"> • check proper flow of inlet water from the mains or from the tank; • check the water stop valve or the tank valve; • check the pump and the self-levelling valve, • check potential leaks; • check the level probe: the presence of limescale and the integrity of the plastic insulation can all effect the auto-fill function.
A3	The machine cannot reach the setpoint temperature within 40 minutes. It can involve: <ul style="list-style-type: none"> • the steam boiler; • the coffee boiler; • the coffee group. 	Key 1B and icon H flashing.	Firstly understand witch part is affected (for example, if there is not steam, the part affected is the steam boiler). Then, in relation to the proper part: <ul style="list-style-type: none"> • check the thermo-fuse or high-limit thermostat continuity. • check the heating element continuity and integrity. • check the LEDs on the control unit and/or on the static relay. • check connections.
A4	The control unit does not receive the signal from a probe. It can involve: <ul style="list-style-type: none"> • the steam boiler pressure transducer; • the coffee boiler temperature probe; • the coffee group temperature probe; • the Easycream temperature probe. 	Key 1A , key 1C , icons T and H flashing.	Check the probe or transducer and its connection to the control unit.
A5	A probe has a short circuit. It can involve: <ul style="list-style-type: none"> • the steam boiler pressure transducer; • the coffee boiler temperature probe; • the coffee group temperature probe; • the Easycream temperature probe. 	Key 1A , key 1C , icons T and H flashing.	Check the probe or transducer and its connection to the control unit.



ALARM	MAIN REASON	KEYPAD SIGNALLING	SOLUTIONS
A6	The control unit cannot sense the water level in the steam boiler.	/	On the level probe: <ul style="list-style-type: none"> • check the presence of limescale; • check the integrity of the plastic insulation.
A7	The machine cannot fill the coffee boiler within 10 seconds.	/	The control unit cannot receive the signal from the flowmeter during the FILLING procedure: <ul style="list-style-type: none"> • check proper flow of inlet water from the mains or from the tank. • check the water stop valve or the tank valve. • check potential leaks. • check the flowmeter connection to the control unit. • check the presence of a blockage: in the flowmeter, its metallic input filter, the restrictor and the not-return valve.
F1		Key 1A , key 1C and icon H flashing.	
A8	General error on memory parameters.	/	Check if the error disappears by switching the machine OFF and ON. If not: <ul style="list-style-type: none"> • reset all machine parameters with the RESET PARAMETERS procedure; • update the firmware or re-install the same firmware version; • change the control unit.
A9	General error on memory counters.	/	Check if the error disappears by switching the machine OFF and ON. If not: <ul style="list-style-type: none"> • reset all machine counters with the RESET COUNTERS procedure; • update the firmware or re-install the same firmware version; • change the control unit.
AA	The CR1220 3 Volt battery has been discharged.	/	Change the CR1220 3 Volt battery on the control unit.
AC	The machine is due for its periodic maintenance.	/	To delete the warning, enter the Alarm Setting menu in the Victoria Arduino E1 APP and press the reset button to reset the cycle counter.
AE	Inlet water pressure less than 0,5 bar for at least 15 seconds.	/	Check the mains pressure.

ALARM	MAIN REASON	KEYPAD SIGNALLING	SOLUTIONS
AF	General error on Bluetooth signal.	/	<p>Check if the error disappears by switching the machine OFF and ON. If not:</p> <ul style="list-style-type: none"> • reset all machine parameters with the RESET PARAMETERS procedure; • update the firmware or re-install the same firmware version; • change the control unit.
-	Low water tank level.	Key 1B and icon T flashing	<p>On the water tank:</p> <ul style="list-style-type: none"> • fill it with water; • check its proper positioning; • check the water tank presence sensor and its connection to the control unit.
-	The control unit cannot receive the signal from the flowmeter within 5 seconds.	Key pressed flashing.	Check as for alarm A7.



11

MAINTENANCE CHECK LIST



INDEX

11	MAINTENANCE CHECK LIST	169
11.1	SIX (6) MONTHS OR 50000 CYCLES MAINTENANCE	170
11.2	TWELVE (12) MONTHS OR 100000 CYCLES MAINTENANCE	171
11.3	ONE (1) YEAR MAINTENANCE KIT.	172

11.1 SIX (6) MONTHS OR 50000 CYCLES MAINTENANCE

Approximate time for service is 1 hour uninterrupted. Consider that the technicians performing the service are aware of safety measures before commencing in regards to isolating power, pressure of steam and pressure of water.

Information should be sought from the site manger for any problems or concerns before commencing work, and to allow sufficient time to complete the task uninterrupted. Remove all covers before commencing and check for damage/signs of leaks.

- | | |
|--|---|
| <input type="checkbox"/> Check for any signs of valves leaking | <input type="checkbox"/> Check for noisy pump motor |
| <input type="checkbox"/> Check and inspect touch screen, ensuring it is not faulty | <input type="checkbox"/> Check for blockage in waste hose |
| <input type="checkbox"/> Check for boiler leaks | <input type="checkbox"/> Check for leaking from hot water pipe |
| <input type="checkbox"/> Check the cleaning cycle counts
Total _____ (if present) | <input type="checkbox"/> Check anti vacuum valve for leaks |
| <input type="checkbox"/> Check the absolute counter
Total _____ (if present) | <input type="checkbox"/> Check the safety valve |
| <input type="checkbox"/> Replace cup gaskets (02280050) | <input type="checkbox"/> Check the auto-fill function |
| <input type="checkbox"/> Replace shower screens (03000066.R) | <input type="checkbox"/> Check steam pressure (_____Bar) |
| <input type="checkbox"/> Check for any signs of leaking in machine | <input type="checkbox"/> Check the static water pressure (_____Bar) |
| <input type="checkbox"/> Check for any damaged wires or caballing | <input type="checkbox"/> Check pump pressure (_____Bar) |
| | <input type="checkbox"/> Check for over all coffee product outcomes |
| | <input type="checkbox"/> Check boiler level |
| | <input type="checkbox"/> Replace the Teflon pipe (11740003) |

NOTE

The water hardness must be less than 6° fr (French degree). The chlorine content must not exceed 100 mg per litre (0.00000361 lb/cu in), otherwise the conditions of guarantee of the machine will expire.

11

Necessary Spare parts

- 1 X 02280050
- 1 X 03000066.R
- 0,5m X 11740003

DATA

SITE NAME

TECHNICIAN

TECHNICIAN SIGNATURE

DATE



11.2 TWELVE (12) MONTHS OR 100000 CYCLES MAINTENANCE

Approximate time for service is 2 hours uninterrupted. Consider that the technicians performing the service are aware of safety measures before commencing in regards to isolating power, pressure of steam and pressure of water.

Information should be sought from the site manger for any problems or concerns before commencing work, and to allow sufficient time to complete the task uninterrupted. Remove all covers before commencing and check for damage/signs of leaks.

Check, adjust, replace (if necessary):

- | | |
|---|--|
| <input type="checkbox"/> Check for any signs of leaking in machine | <input type="checkbox"/> Check and inspect touch screen, ensuring it is not faulty |
| <input type="checkbox"/> Check for any damaged wires or caballing | <input type="checkbox"/> Check for boiler leaks |
| <input type="checkbox"/> Check for noisy pump motor | <input type="checkbox"/> Check the cleaning cycle counts Total _____ (if present) |
| <input type="checkbox"/> Check for blockage in waste hose | <input type="checkbox"/> Replace cup gaskets (02280050) |
| <input type="checkbox"/> Check for leaking from hot water pipe | <input type="checkbox"/> Replace shower screens (03000066.R) |
| <input type="checkbox"/> Check the safety valve | <input type="checkbox"/> Replace anti vacuum Valve (01000023) |
| <input type="checkbox"/> Check the auto-fill function | <input type="checkbox"/> Replace pre-infusion chamber gasket (02280012) |
| <input type="checkbox"/> Check the steam pressure (_____Bar) | <input type="checkbox"/> Replace steam arm o-rings (02280036) |
| <input type="checkbox"/> Check the static water pressure (_____Bar) | <input type="checkbox"/> Replace steam arm protectors (05000660) |
| <input type="checkbox"/> Check pump pressure (_____Bar) | <input type="checkbox"/> Replace the Neplax Valve (98120001) |
| <input type="checkbox"/> Check for over all coffee product outcomes | <input type="checkbox"/> Replace the Teflon pipe (11740003) |
| <input type="checkbox"/> Check boiler level | <input type="checkbox"/> Replace the check valves (98110001) |
| <input type="checkbox"/> Check for any signs of valves leaking | <input type="checkbox"/> Replace the o-ring gasket (02600006) |
| | <input type="checkbox"/> Replace the compass joint steam-water wand (07300872) |

NOTE

The water hardness must be less than 6° fr (French degree). The chlorine content must not exceed 100 mg per litre (0.00000361 lb/cu in), otherwise the conditions of guarantee of the machine will expire.

<p>Necessary Spare parts</p> <ul style="list-style-type: none"> • 1 X 02280050 • 1 X 03000066.R • 1 X 01000023 • 1 X 02280012 • 1 X 05000660 • 1 X 02280036 • 1 X 98120001 • 0,5m X 11740003 • 1 X 98110001 • 1 X 02600006 • 1 X 07300872

<p>DATA</p> <p>SITE NAME _____</p> <p>TECHNICIAN _____</p> <p>TECHNICIAN SIGNATURE _____</p> <p>DATE _____</p>

11.3 ONE (1) YEAR MAINTENANCE KIT

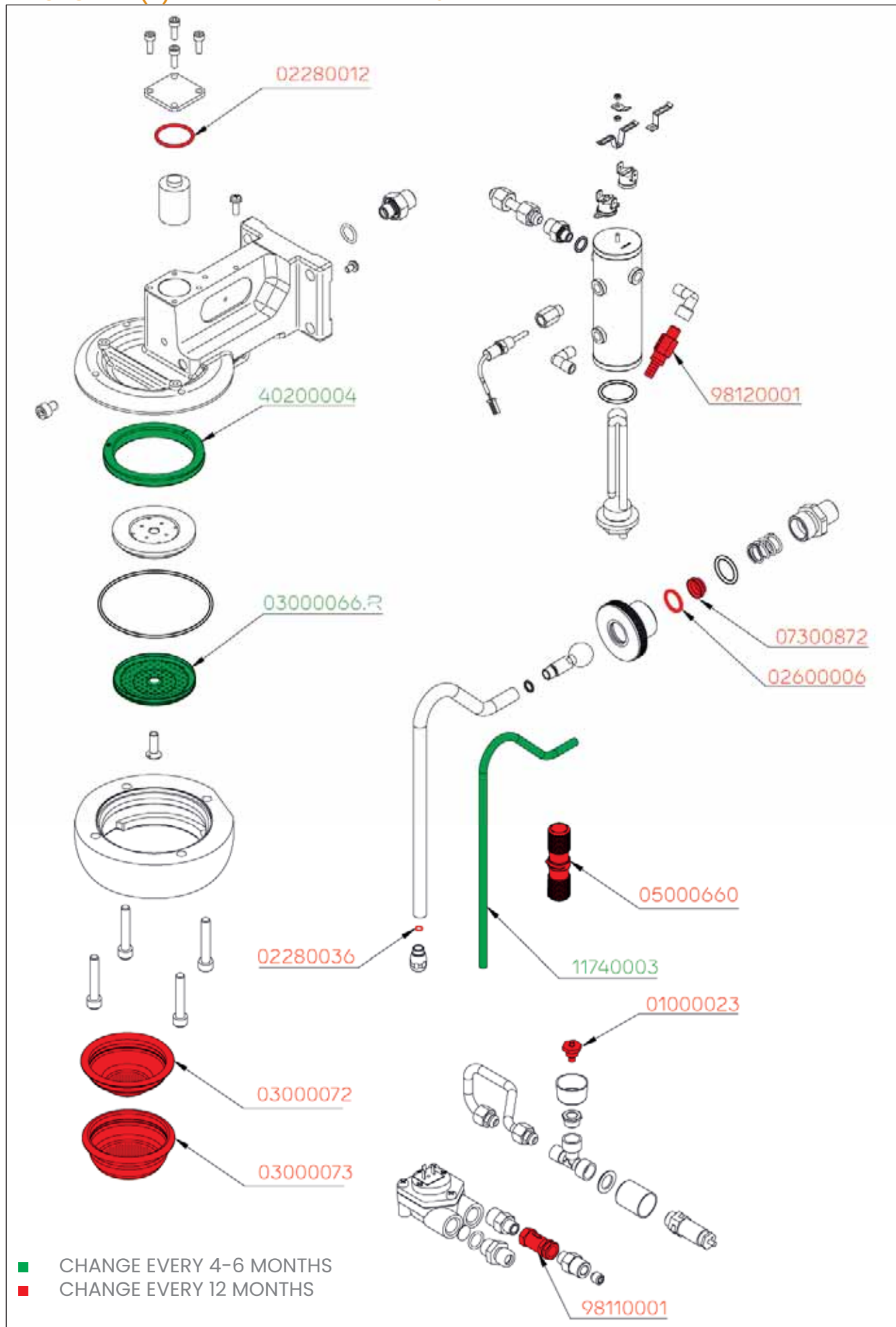

11

12

TROUBLESHOOTING

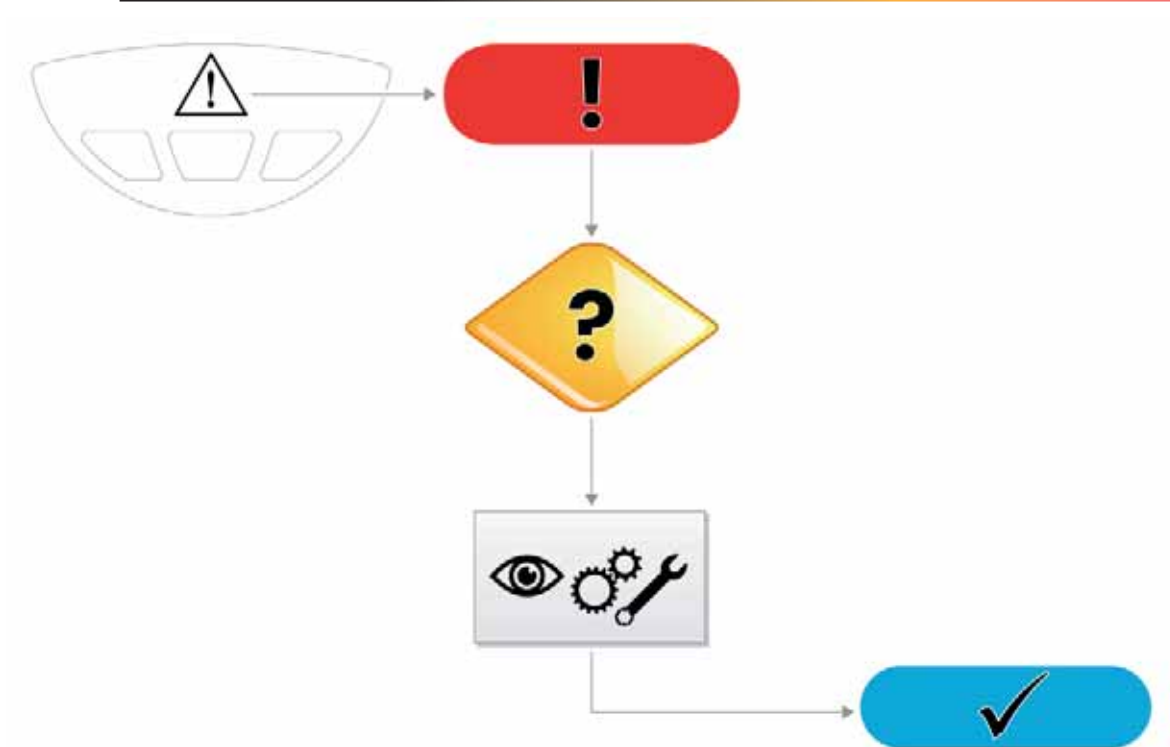

INDEX

12	TROUBLESHOOTING	173
12.1	COFFEE DOSAGE ERROR	174
12.2	BOILER FILLING TIME OUT	175
12.3	HEATING TIMEOUT	176
12.3.1	STEAM BOILER HEATING ERROR	176
12.3.2	COFFEE BOILER HEATING ERROR	177
12.3.3	COFFEE GROUP HEATING ERROR	178

12.1 COFFEE DOSAGE ERROR

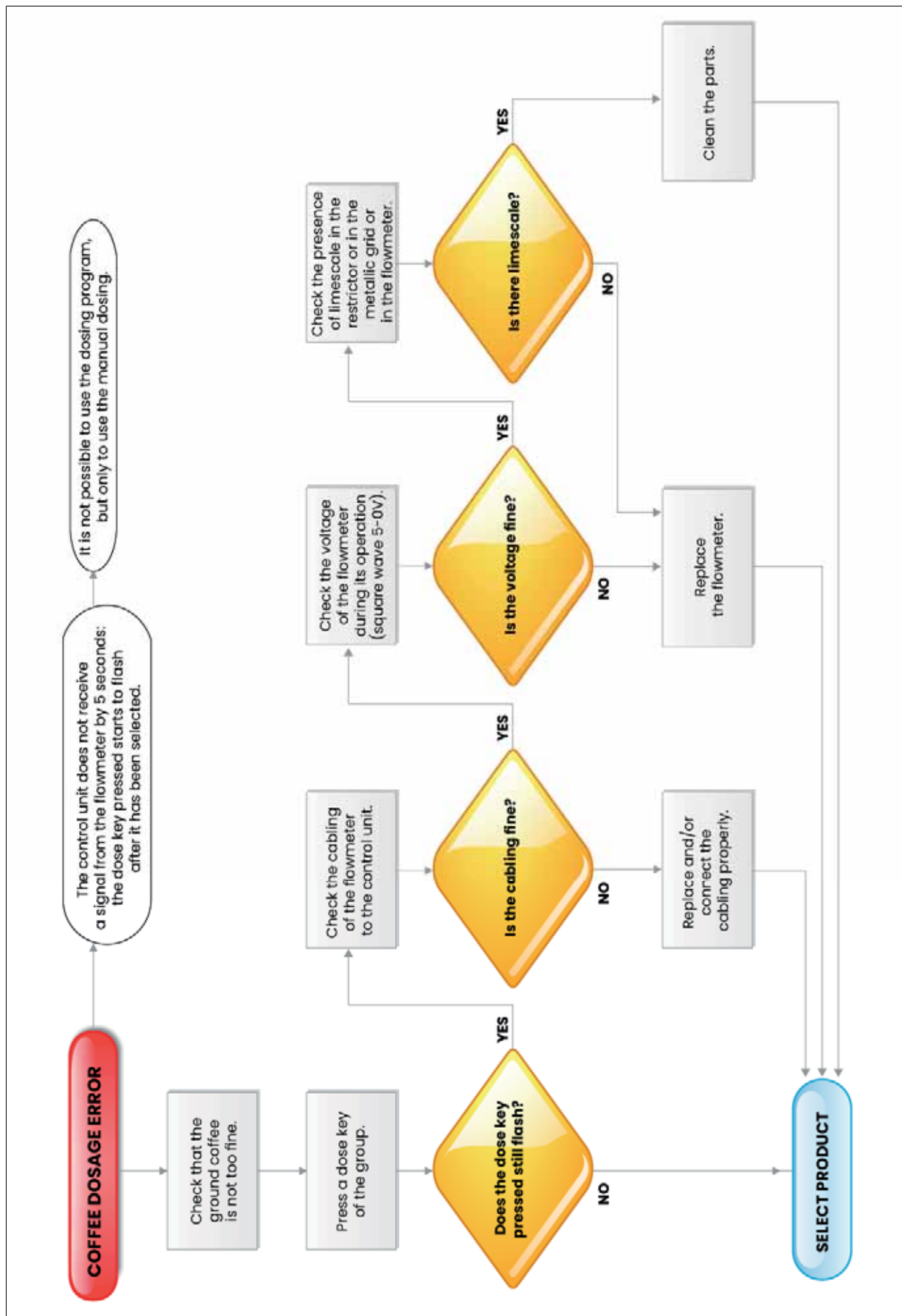

12.2 BOILER FILLING TIME OUT

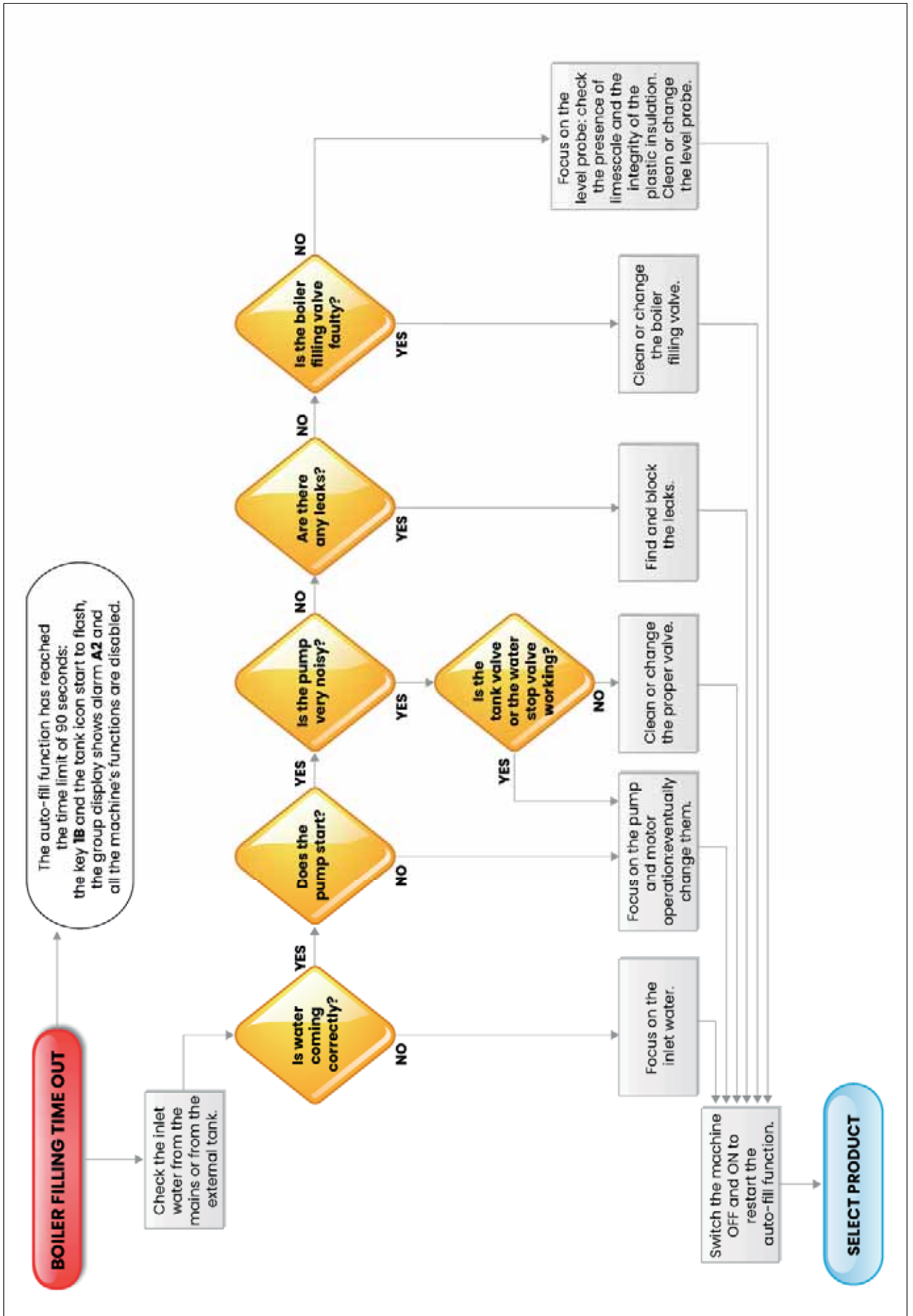

12.3 HEATING TIMEOUT

12.3.1 STEAM BOILER HEATING ERROR

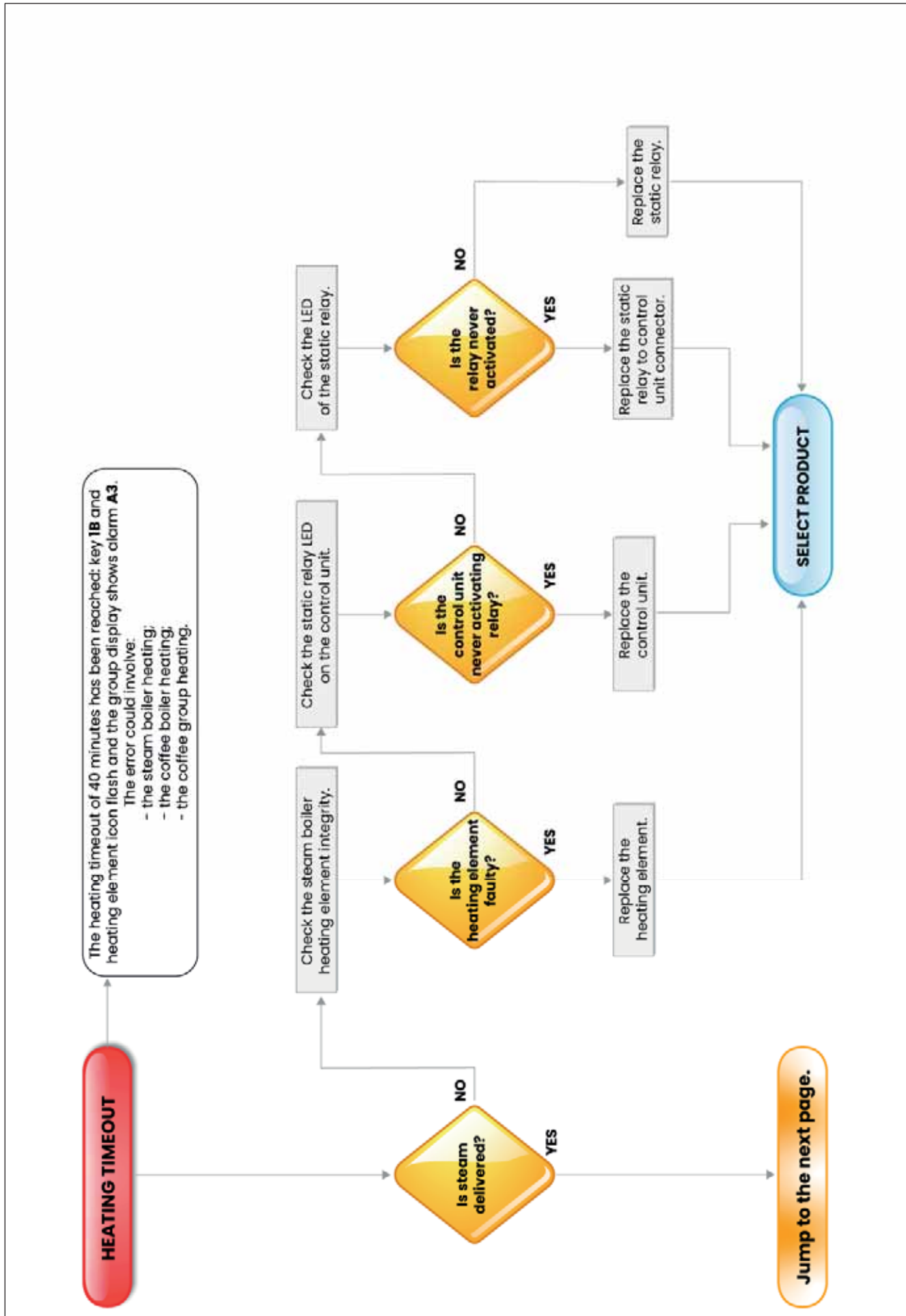

12.3.2 COFFEE BOILER HEATING ERROR

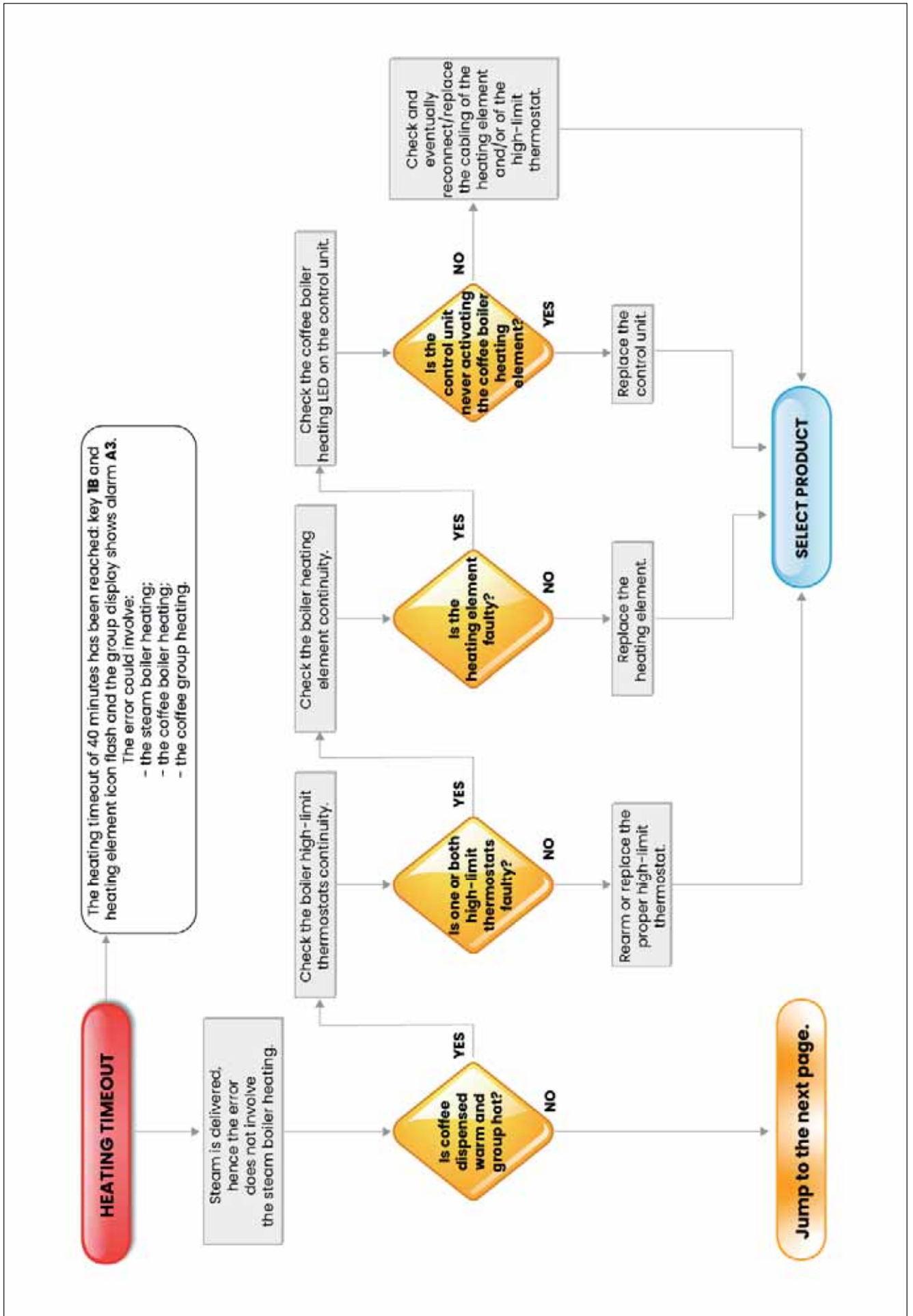

12.3.3 COFFEE GROUP HEATING ERROR

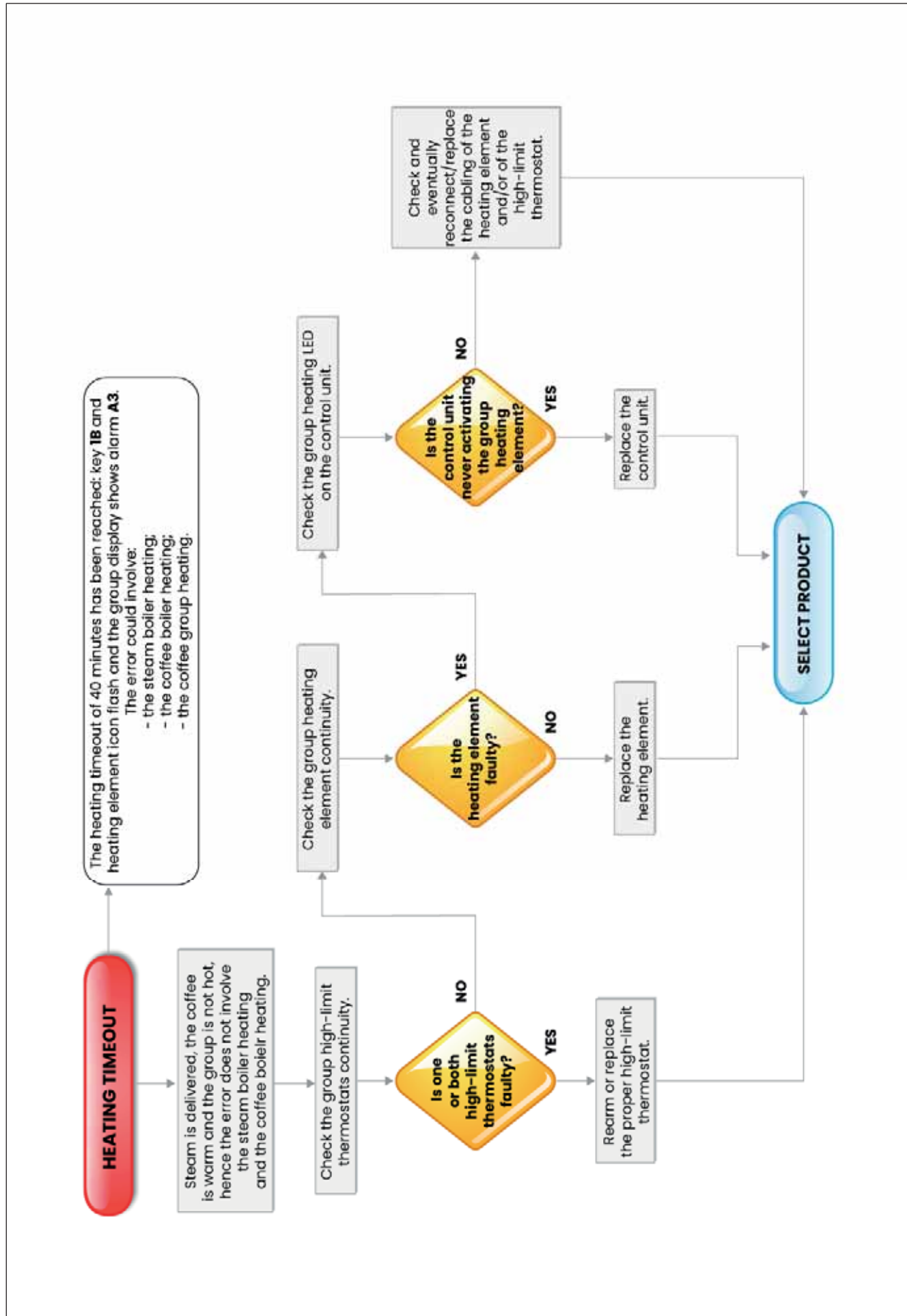

13

DIAGRAMS

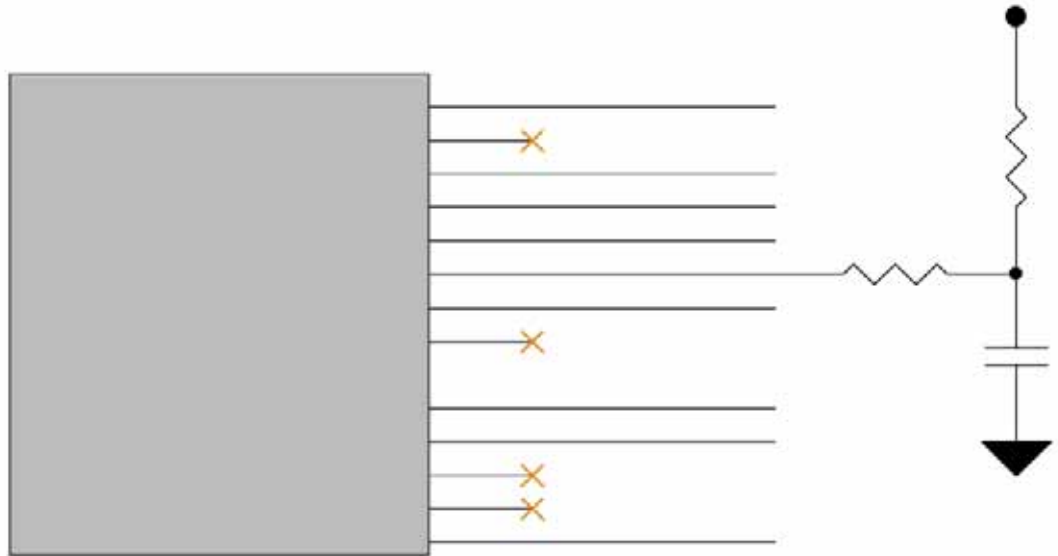

INDEX

13	DIAGRAMS	179
13.1	HYDRAULIC SCHEME	180
13.2	230V ELECTRICAL DIAGRAM	182
13.3	110V ELECTRICAL DIAGRAM	184
13.4	BOILER DIAGRAM	186

13.1 HYDRAULIC SCHEME

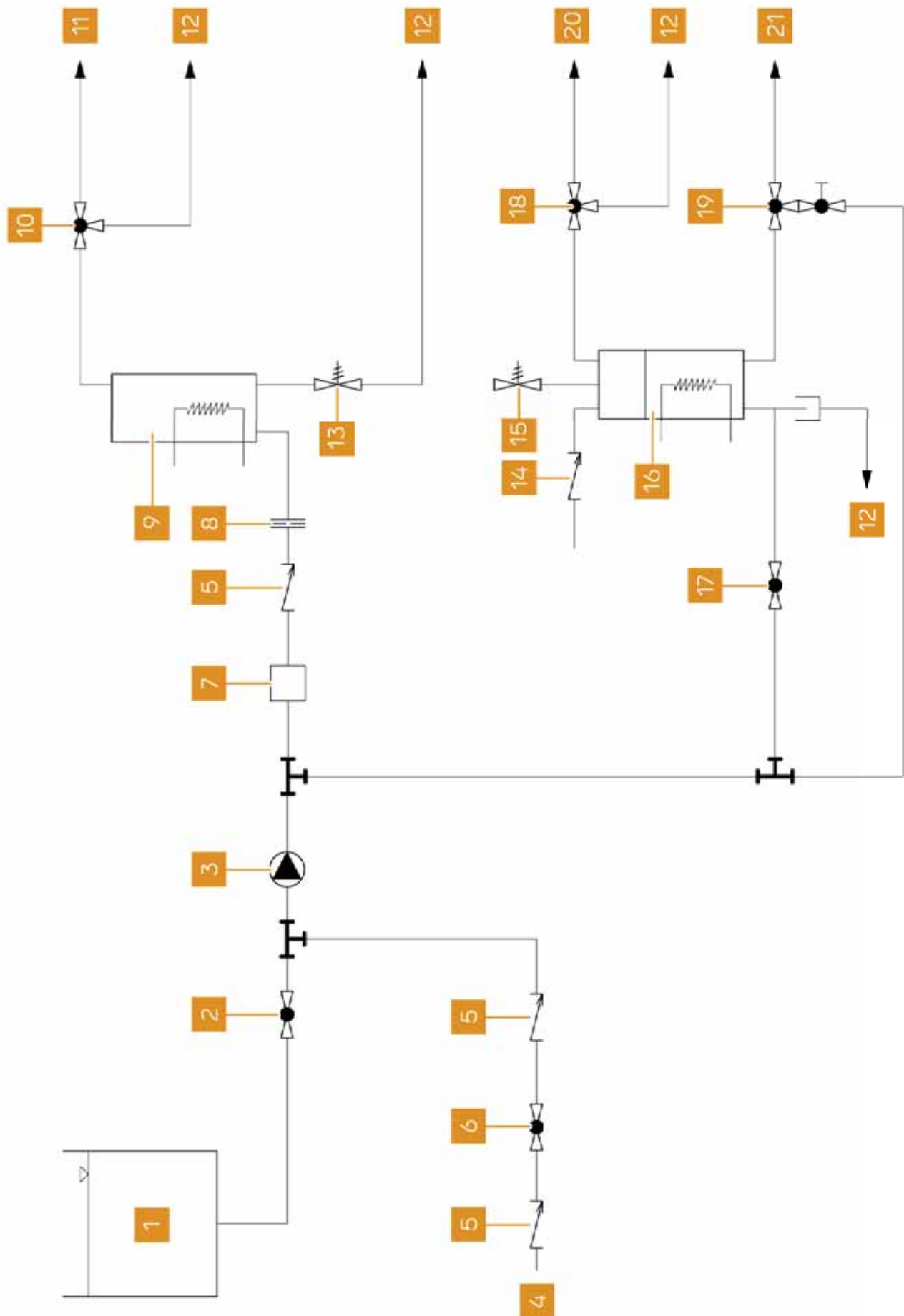

POSITION	DESCRIPTION
1	Water tank
2	Water tank electrovalve
3	Pump 10 bar - 70 l/h - 170 W
4	Water mains inlet
5	Check valve
6	Water mains inlet electrovalve
7	Flowmeter
8	Calibrated orifice
9	Coffee boiler 0.14 l - 600 W
10	Pouring group electrovalve
11	Filter holder outlet
12	Discharge outlet
13	Safety valve 16,5 bar
14	Anti-vacuum valve
15	Safety valve 3 bar
16	Steam boiler 1,5 l - 1600 W
17	Water level electrovalve
18	Steam electrovalve
19	Water inlet electrovalve
20	Steam wand outlet
21	Hot water outlet

13.2 230V ELECTRICAL DIAGRAM

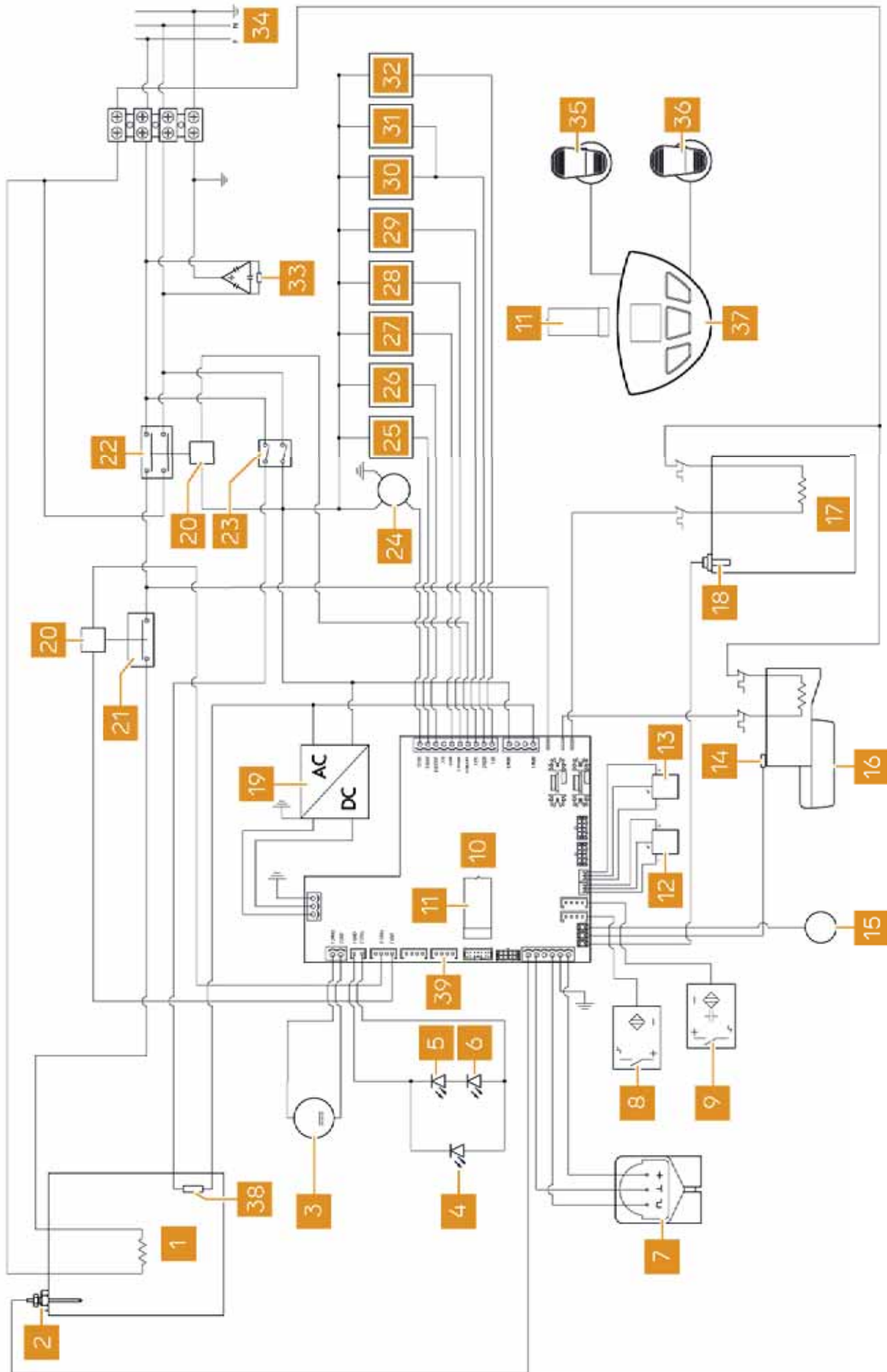

POSITION	DESCRIPTION
1	Steam boiler heating element (1600 W)
2	Steam boiler temperature probe
3	Compressor
4	LED strip
5	Left LED spotlight
6	Right LED spotlight
7	Volumetric counter
8	Filter holder presence sensor
9	Water tank presence sensor
10	Control unit
11	Keyboard flat
12	Hot water pressure transducer
13	Steam boiler pressure transducer
14	Pouring group temperature probe
15	Easycream temperature probe
16	Pouring group heating element (300 W)
17	Coffee boiler heating element (600 W)
18	Coffee boiler temperature probe
19	AC/DC Transformer
20	Relay
21	Relay switch
22	Power relay
23	Master switch
24	Pump motor
25	Tank solenoid valve
26	Water stop solenoid valve
27	Air solenoid valve
28	Steam solenoid valve
29	Level solenoid valve
30	Steam / Hot water solenoid valve
31	Steam / Hot water solenoid valve
32	Pouring group solenoid valve
33	Fuse
34	230 V single phase power IN
35	Steam knob connector (CN2)
36	Hot water knob connector (CN3)
37	Keyboard and ghost display
38	Thermo-fuse
39	Remote control module

13.3 110V ELECTRICAL DIAGRAM

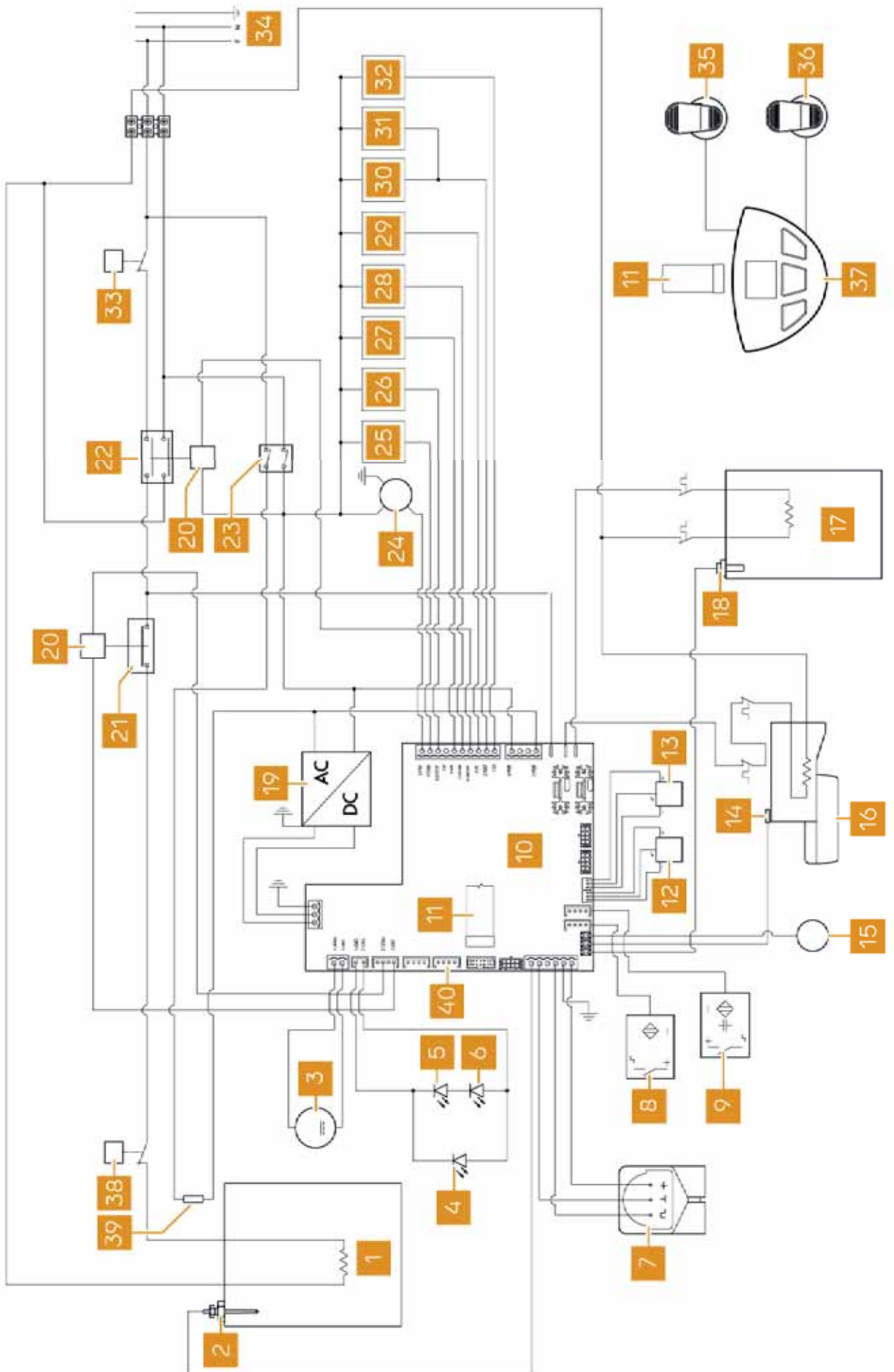

13



POSITION	DESCRIPTION
1	Steam boiler heating element (1600 W)
2	Steam boiler temperature probe
3	Compressor
4	LED strip
5	Left LED spotlight
6	Right LED spotlight
7	Volumetric counter
8	Filter holder presence sensor
9	Water tank presence sensor
10	Control unit
11	Keyboard flat
12	Hot water pressure transducer
13	Steam boiler pressure transducer
14	Pouring group temperature probe
15	Easycream temperature probe
16	Pouring group heating element (300 W)
17	Coffee boiler heating element (600 W)
18	Coffee boiler temperature probe
19	AC/DC Transformer
20	Relay
21	Relay switch
22	Power relay
23	Master switch
24	Pump motor
25	Tank solenoid valve
26	Water stop solenoid valve
27	Air solenoid valve
28	Steam solenoid valve
29	Level solenoid valve
30	Steam / Hot water solenoid valve
31	Steam / Hot water solenoid valve
32	Pouring group solenoid valve
33	Temperature switch
34	110 V single phase power IN
35	Steam knob connector (CN2)
36	Hot water knob connector (CN3)
37	Keyboard and ghost display
38	Pressure switch
39	Thermo-fuse
40	Remote control module

13.4 BOILER DIAGRAM

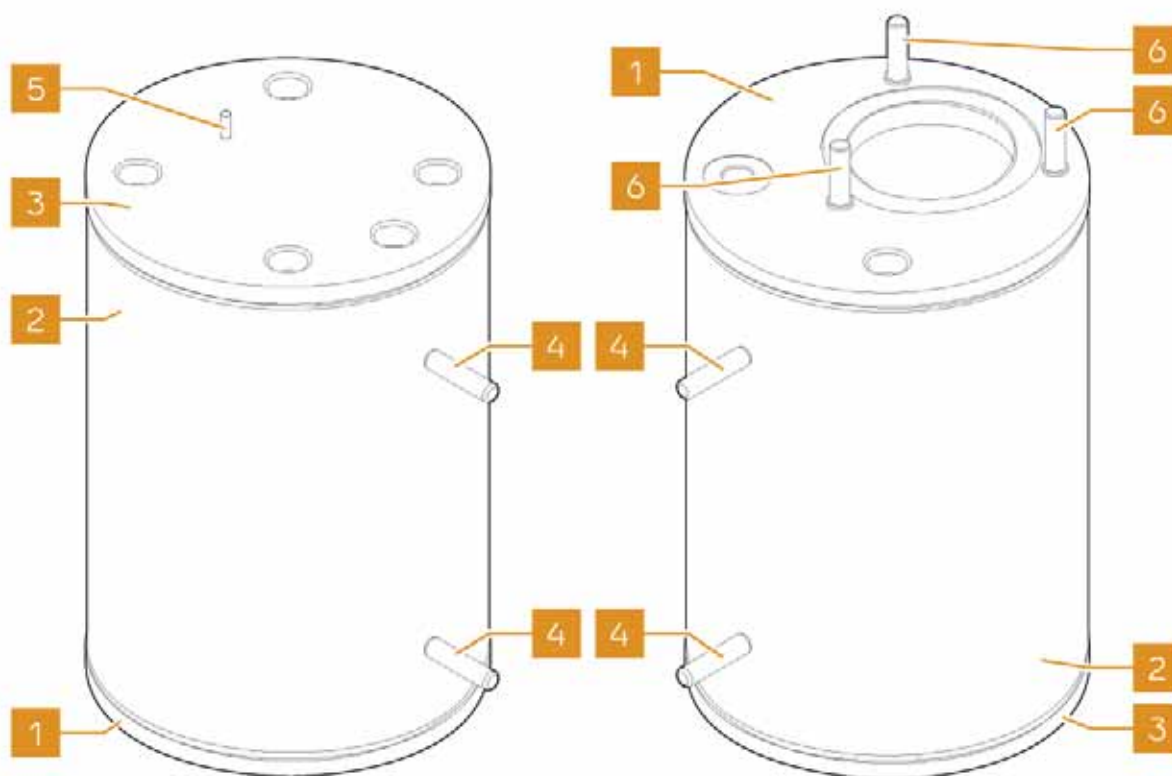

PROJECT DATA FOR DIRECTIVE PED 97/23/CE

VOLUMES	1,5 l
TS	139°C
P.V.S.	2.5 Bar
PT	4 Bar
FLUID	H2O

NO.	Q.TY	PART NUMBER	DESCRIPTION	MATERIAL
1	1	98031201	Lower flange	
2	1	98031201	Boiler body	INOX AISI 316L
3	1	98031201	Upper flange	INOX AISI 316L
4	2	00080750	M6x25 Captive screw	INOX
5	1	00080800	M3x8 Captive screw	INOX
6	3	00081410	M6x20 Captive screw	INOX

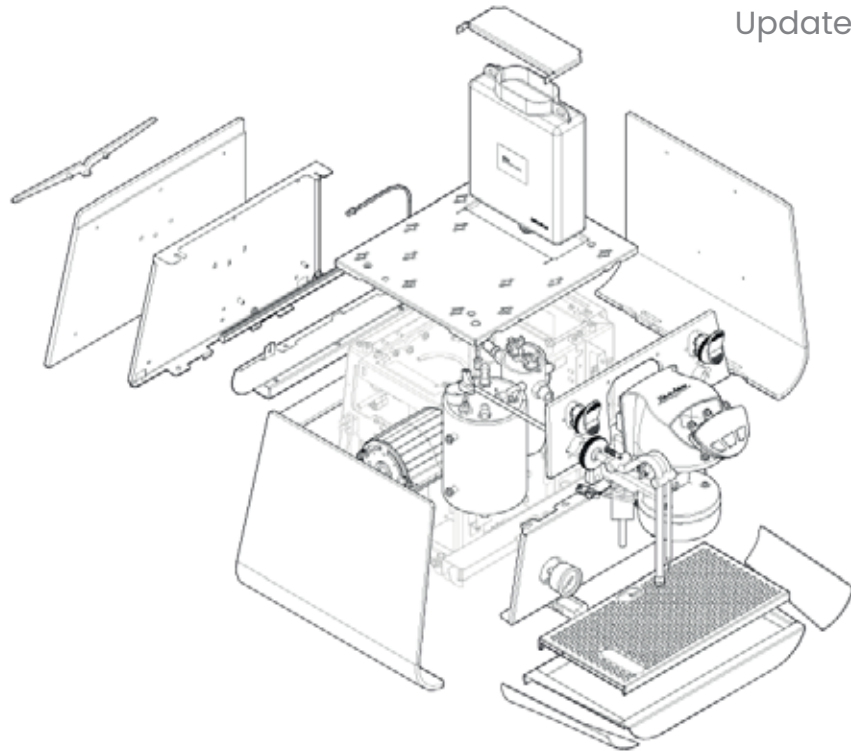

INDEX

14	SPARE PARTS	.187
14.1	CABINET PARTS	188
14.2	CONTROL PANEL PARTS	190
14.3	POURING GROUP PARTS	192
14.4	HYDRAULIC PARTS	194
14.5	STEAM & HOT WATER PARTS	196
14.6	EASYCREAM PARTS	198
14.7	HYDRAULIC GROUP PARTS	200
14.8	BOILER PARTS	202
14.9	FRAME PARTS	204
14.10	ELECTRONIC & ELECTRICAL PARTS	206

NOTE

The codes written in bold refer to the components employed currently. The codes used before are written in *cursive* with indicated, on the side, the end of validity date.

14.1 CABINET PARTS

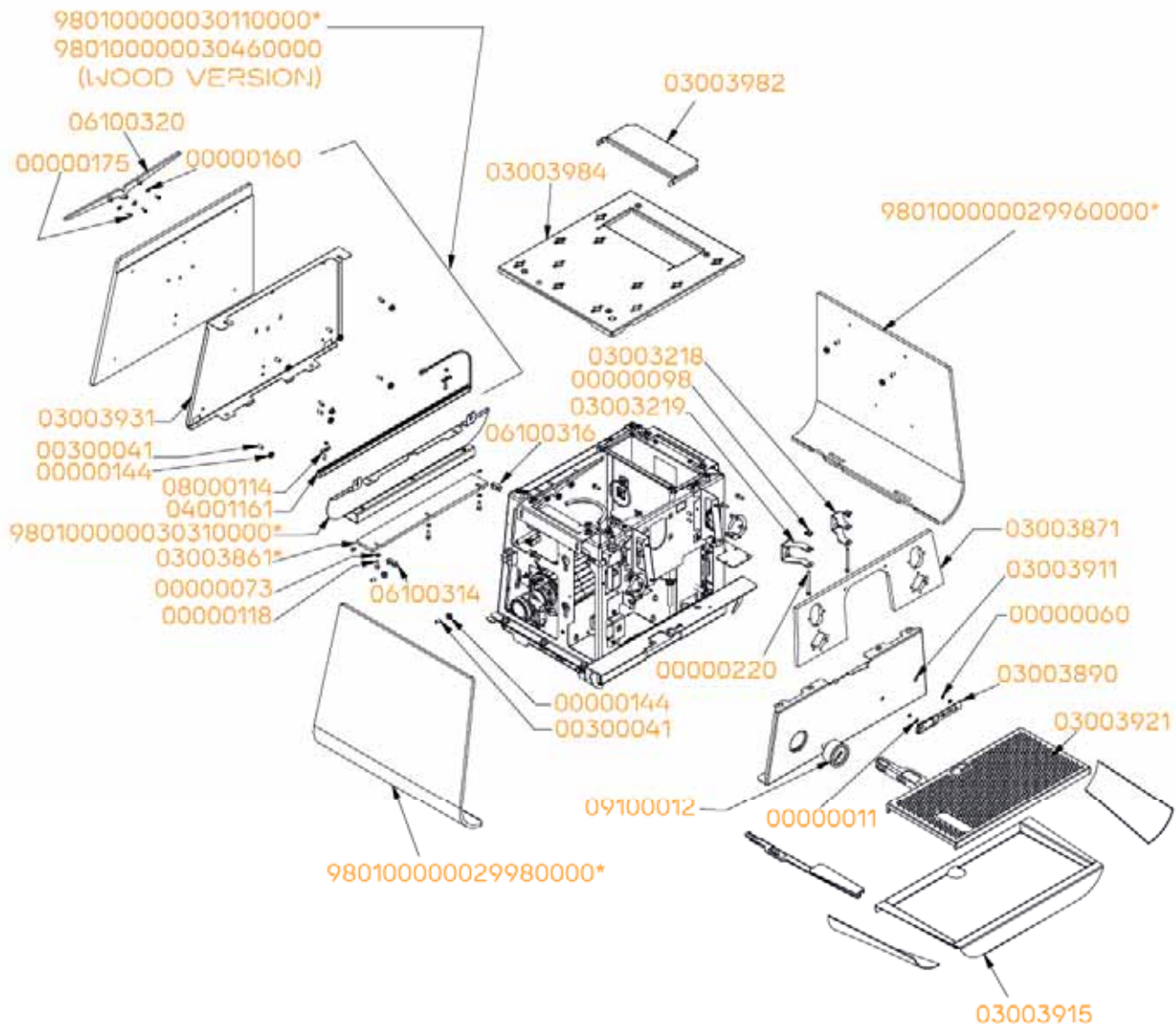

NOTE

* Specify colour.

CODE	DESCRIPTION	END VALIDITY
00000011	S/S KNURLED WASHER M4 UNI8842/A	
00000060	GALVANIC MEDIUM NUT AQ M3	
00000098	CAGE NUT M4 T424 - THICKNESS 1,7-2,3	
00000220	S/S SOCKET SCREW M4x45 FULLY THREADED	

CODE	DESCRIPTION	END VALIDITY
00000073	S/S WASHER D.8x4x1 UNI6592	
00000118	S/S HEX SOCKET CAP SCREW M4x12 5931	
00000144	GALVANIC FLANGED NUT M5 UNI 6923	
00000160	S/S WASHER D4X12 UNI 6593	
00000175	S/S CROSS HEAD CAP SCREW M4X10	
00300041	S/S FH GRUB SCREW M5x10	
03003218	RIGHT SUPPORT COVER GROUP VA388	
03003219	LEFT SUPPORT COVER GROUP VA388	
03003861	REAR INFERIOR PROFILE EAGLE ONE 1GR ALUMINIUM	
03003861.BV	REAR INFERIOR PROFILE WHITE	
03003861.NOV	REAR INFERIOR PROFILE MATT BLACK	
03003871	FRONTAL PANEL 1GR EAGLE ONE CHROMED ALUMINIUM	
03003890	FRONT SIDE LOGO EAGLE ONE PRIMA	
03003911	INFERIOR FRONT PLATE 1GR EAGLE ONE	
03003915	DRIP TRAY 1GR	
03003921	MESH WORKTOP 1GR EAGLE ONE	
03003931	SUP BACK PANEL SUPPORT 1GR	
03003982	TANK COVER 1GR.	
03003984	SUPERIOR CUP HOLDER 1GR.	
04001161	LED STRIP 1GR EAGLE ONE	
06100314	RIGHT TERMINAL INFERIOR BACKSIDE PROFILE	
06100316	LEFT TERMINAL INFERIOR BACKSIDE PROFILE	
06100320	REAR EAGLE LOGO STEELUX	
08000114	SPRING REAR LED FIXING	
09100012	GAUGE SCALE 0-4 BAR 1/8 D.40 VA	
980100000029960001	RIGHT SIDE PANEL 1GR. STEELUX	
980100000029960002	RIGHT SIDE PANEL 1GR. MATT BLACK	
980100000029960003	RIGHT SIDE PANEL 1GR. WHITE	
980100000029960004	RIGHT SIDE PANEL 1GR. RED CAPPELLINI	
980100000029960005	RIGHT SIDE PANEL 1GR. GREEN CAPPELLINI	
980100000029960006	RIGHT SIDE PANEL 1GR. BLUE CAPPELLINI	
980100000029980001	LEFT SIDE PANEL 1GR. STEELUX	
980100000029980002	LEFT SIDE PANEL 1GR. MATT BLACK	
980100000029980003	LEFT SIDE PANEL 1GR. WHITE	
980100000029980004	LEFT SIDE PANEL 1GR. RED CAPPELLINI	
980100000029980005	LEFT SIDE PANEL 1GR. GREEN CAPPELLINI	
980100000029980006	LEFT SIDE PANEL 1GR. BLUE CAPPELLINI	
980100000030110001	REAR PANEL ASS. 1 GR. STEELUX WITH LIGHTS	
980100000030110002	REAR PANEL ASS. 1 GR. MATT BLACK WITH LIGHTS	
980100000030110003	REAR PANEL ASS. 1 GR. WHITE WITH LIGHTS	
980100000030110004	REAR PANEL ASS. 1 GR. CAPPELLINI RED WITH LIGHTS	
980100000030110005	REAR PANEL ASS. 1 GR. CAPPELLINI GREEN WITH LIGHT	
980100000030110006	REAR PANEL ASS. 1 GR. CAPPELLINI BLUE WITH LIGHTS	
980100000030310001	INFERIOR RETRO FRAME SET 1GR STEELUX	
980100000030310002	INFERIOR RETRO FRAME SET 1GR MATT BLACK	
980100000030460000	BACKSIDE FRAME EAGLE ONE 1GR WOOD	
980100000030560000	RIGHT SIDE PANEL EAGLE ONE SPECIAL COLOUR	
980100000030570000	LEFT SIDE PANEL EAGLE ONE SPECIAL COLOUR	
980100000030610000	REAR INFERIOR PROFILE 1GR SPECIAL COLOUR	
980100000030660000	BACKSIDE FRAME 1GR SPECIAL COLOUR	
980100000030810000	REAR EAGLE LOGO EAGLE ONE SPECIAL COLOUR	



14.2 CONTROL PANEL PARTS

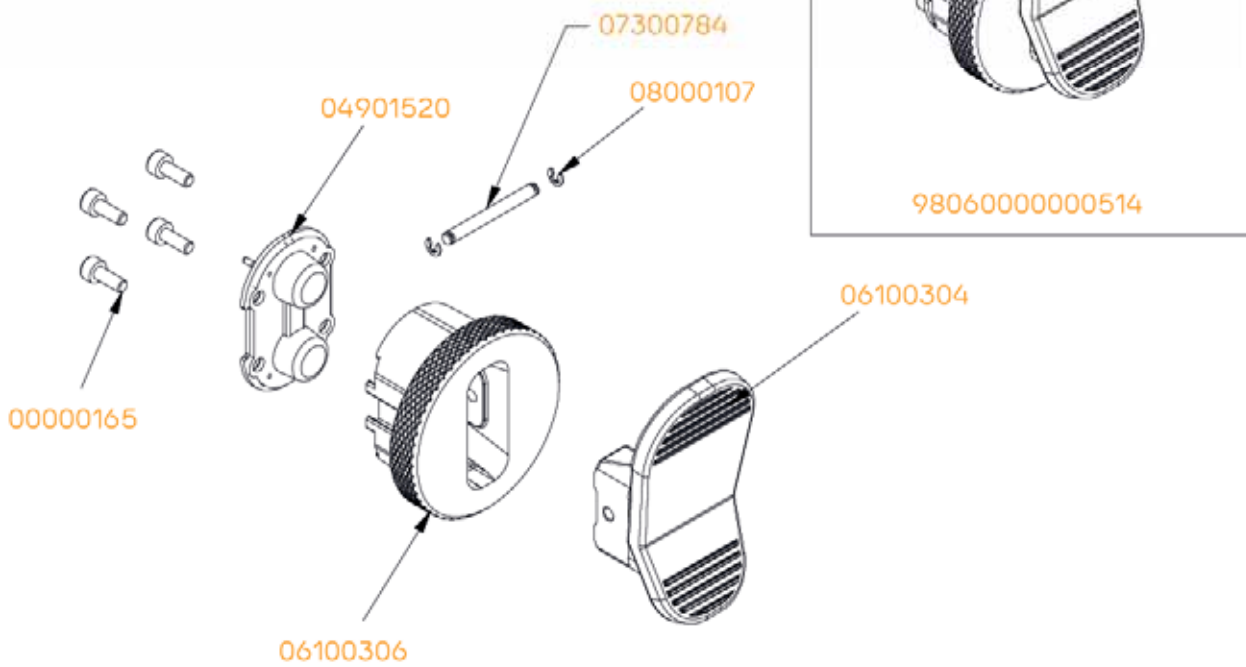
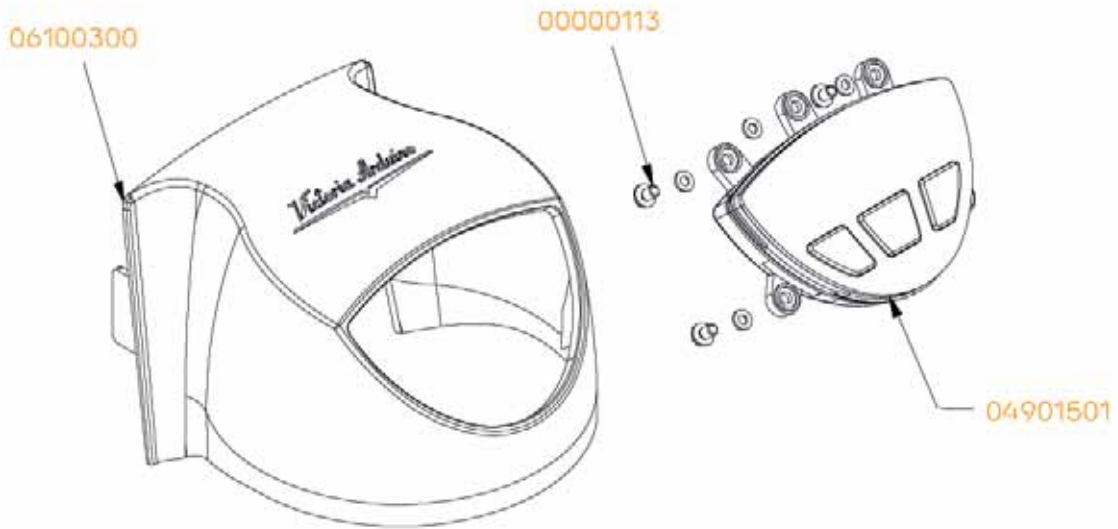

CODE	DESCRIPTION	END VALIDITY
00000113	S/S CROSS HEAD CAP SCREW M4x6 7985	
00000165	S/S SCREW M3x8 TCEI ISO 4762	
04901501	DISPENSING BOARD	
04901520	ELECTRONIC CONTROL BOARD W/ STEAM LEVER MAT	
06100300	GROUP COVER EAGLE ONE CHROME	
06100304	STEAM LEVER EAGLE ONE	
06100306	LEVER SUPPORT EAGLE ONE	
07300784	STEAM LEVER LOCK PIVOT EAGLE ONE	
08000107	LOCKING SPRING FOR STEAM TAP EAGLE ONE	
98060000000514	STEAM KNOB ASSEMBLY	



14.3 POURING GROUP PARTS

NOTE

* Specify version.

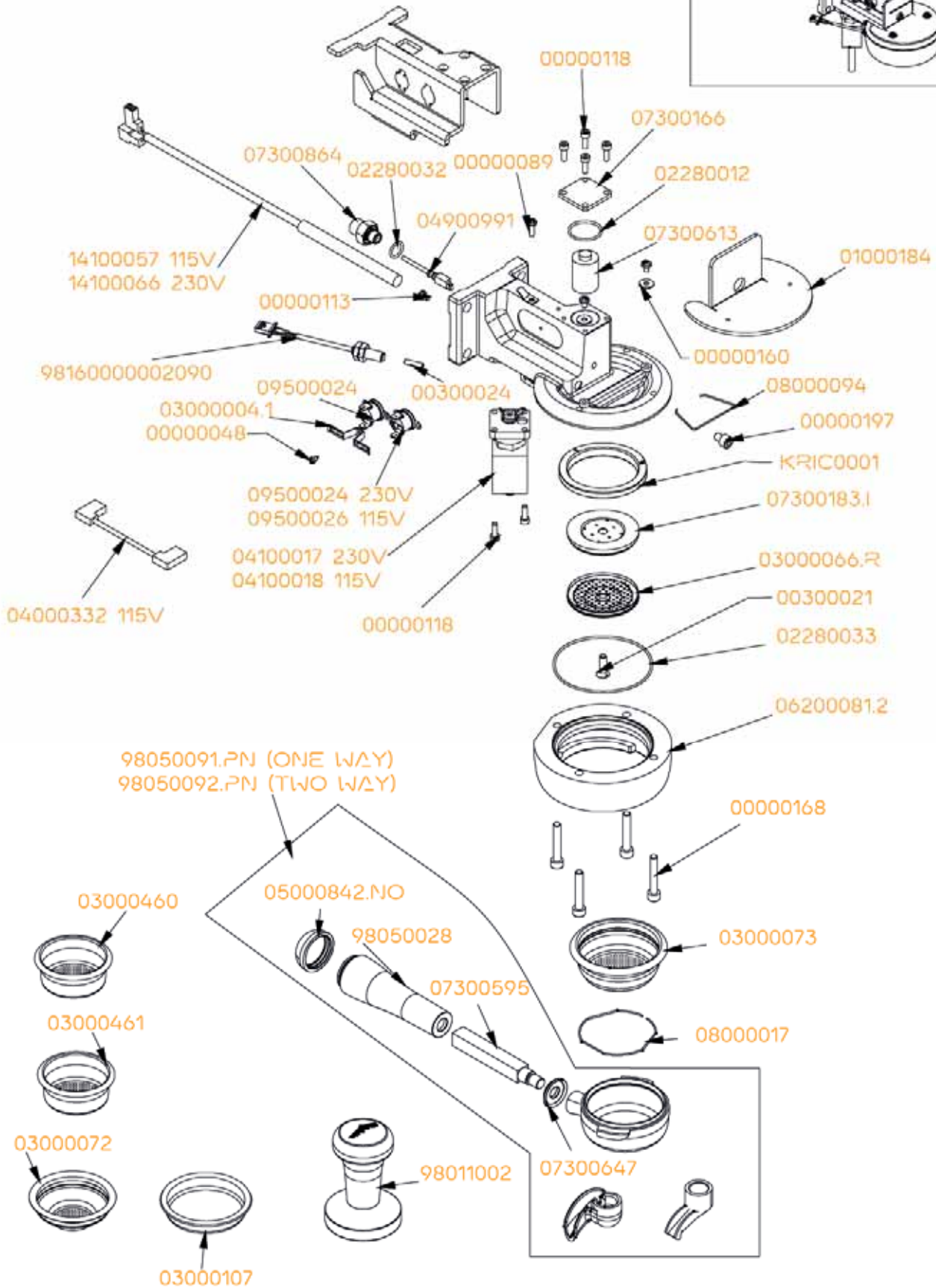
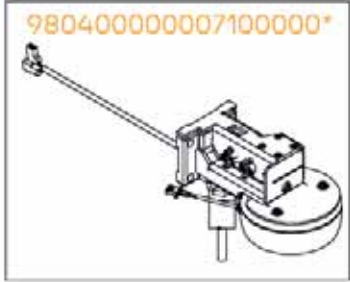

CODE	DESCRIPTION	END VALIDITY
00000048	SELF-TAPPING SCREW 2.9x4.5 TC/T.CR.	
00000089	S/S CROSS HEAD CAP SCREW M4x12 DIN7985	
00000113	S/S CROSS HEAD CAP SCREW M4x6 7985	
00000118	S/S HEX SOCKET CAP SCREW M4x12 5931	
00000160	S/S WASHER D4X12 UNI 6593	
00000168	S/S HEXAGON SOCKET HEAD SCREW M6x35 UNI 5931	
00000197	S/S HEX SOCKET CAP SCREW M6x8 ISO 4762	
00300021	S/S SLT COUNTERSUNK SCREW M6X18 DIN963	
00300024	S/S GRUB SCREW M4X16 5923	
01000184	ADONIS GROUP INSULATOR	
02280012	GASKET O RING 2093 D.27 EP851	
02280032	GASKET O RING 114 D15 EP 851	
02280033	GASKET O RING 75,92x1,78 NBR XP70	
03000004.1	DOUBLE BRACKET FOR THERMOSTAT	
03000066.R	S/S SHOWER REINFORCED	
03000072	FILTER ONE COFFEE HIGH 7gr	
03000073	FILTER TWO COFFEE HIGH 14gr	
03000107	BLIND FILTER	
03000460	COFFEE FILTER 20gr (RIDGE-LESS)	
03000461	COFFEE FILTER 18gr (RIDGE-LESS)	
04000332	EXT L=85 + FASTON F-F A FLAG AWG18	
04100017	3WAY SOLENOID DIS BASE 1/8 220-230V 50/60Hz CE	
04100018	3WAY SOLENOID DIS BASE 1/8110-120V60Hz F1.6 UL	
04900991	GROUP TEMPERATURE PROBE PT1000	
05000842.NO	FILTER HOLDER KNOB LOCK 2003 PAINTED MATT BLACK	
06200081.2	GR RING OR CHROME OT-58 - FILTER HOLDER SENSOR	
07300166	FLANGE BLOCK LOCK SOLENOID HOLDER	
07300183.I	GROUP DIFFUSER h=3 S/S Aisi316	
07300595	FILTER HOLDER KNOB INSERT 2003 AVP ZINC.	
07300613	PRE INFUSION CHAMBER INSERT GROUP	
07300647	S/S WASHER FILTER HOLDER KNOB DIFFUSER	
07300864	FITTING 1/4M 1/8M + THREADED M6 Aisi316 +	
08000017	S/S FILTER LOCKING SPRING	
08000094	INSULATION SHEET SPRING DELIVERY GROUP	
09500024	MANUAL THERMOSTAT 135°C TRIP FREE GREEN DRIPPI	
09500026	AUTOMATIC THERMOSTAT 110°C	
14100057	HEATING ELEMENT D10x115 300W 115V	
14100066	CARTRIDGE HEAT. ELEMENT D10x115 300W 230V	
98011002	ANODISED COFFEE TAMPER BRILLIANT WHITE	
980400000007100001	DISPENSING GROUP SET 1 GROUP CE	
980400000007100002	DISPENSING GROUP SET 1 GROUP CSA	
98050028	BLACK LEATHER FILTER HOLDER HANDLE	
98050091.PN	1 WAY FILTER HOLDER IN BLACK LEATHER W/OUT FILTER	
98050092.PN	2 WAYS FILTER HOLDER IN BLACK LEATHER W/OUT FILTER	
98160000002090	FILTER HOLDER PRESENCE SENSOR W/CONNECTORS	
KRIC0001	6 x PK LONGLIFE CONICA GASKET SHEATH AURELIA-VA	

14.4 HYDRAULIC PARTS

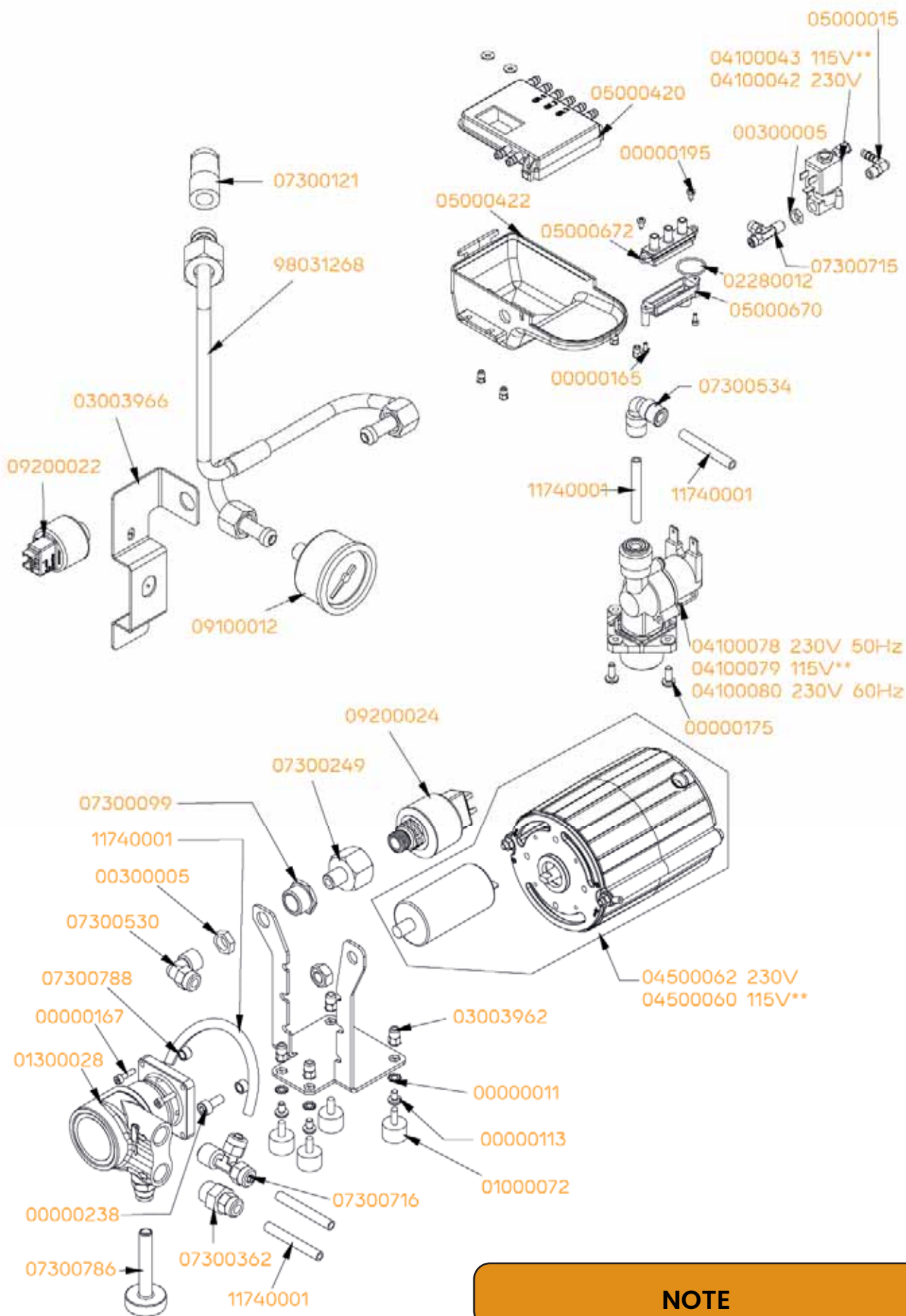

NOTE

** North America Market.

CODE	DESCRIPTION	END VALIDITY
00000011	S/S KNURLED WASHER M4 UNI8842/A	
00000113	S/S CROSS HEAD CAP SCREW M4x6 7985	
00000165	S/S SCREW M3x8 TCEI ISO 4762	
00000167	S/S SCREW M3x12 TCEI ISO 4762	
00000175	S/S CROSS HEAD CAP SCREW M4X10	
00000195	S/S SELF TAPPING SCREW 3,9X9,5 TC/TCR	
00000238	STAINLESS STEEL SCREW M5x12 TCEI	
00300005	BRASS NUT 1/8 GAS D4 ADD 22.07.96 CHI3	
01000072	ANTI-VIBRATING AD 10X10 M4 MM	
01300028	PUMP GA072	
02280012	GASKET O RING 2093 D.27 EP851	
04100042	2WAY SOLENOID 1/8-1/8 220-230V50/60Hz F2 CE	
03003962	PUMP SUPPORT BRACKET	
03003966	MANOMETER SUPPORT BRACKET	
04100043	2WAY SOLENOID 1/8-1/8 110-120V 60Hz F2 UL TH1xM4	
04100058	2WAY SOLENOID 1/8-1/8 208-240V 60Hz F2 UL TH2xM3	
04100078	SOLENOID VALVE 2WAYS 3/4-JG 230V 50/60Hz	
04100079	SOLENOID VALVE 2 WAYS 3/4-JG115V 60Hz UL	
04100080	SOLENOID VALVE 2 WAYS 3/4-JG6 UL 208/240V60Hz	
04500060	MOTOR 115V	
04500062	MOTOR 230V	
05000015	TUBE FASTENING WES 6R 1/8	
05000420	TRAY PLUG UNDER PLATE VA388	
05000422	DRIP TRAY UNDER PLATED VA388	
05000670	LOWER EXHAUST MANIFOLD	
05000672	UPPER EXHAUST MANIFOLD	
07300099	FITTING ADAPTER 3/8-1/4 ES. 20 ADD. 29.05.96	
07300121	FITTING L 1/4 M-M CYLINDER ADD. 18.02.97	
07300249	FITTING 1/8M L = 12 3/8F	
07300362	STRAIGHT FITTING 1/4 M-FITTINGS.6 340	
07300530	FITTING L 1/8 F A CALZ. 347 6	
07300534	RAPID FITTING L D6 - D6	
07300715	T FITTING 1/8 M -FITTINGS.6 -FITTINGS.6	
07300716	T FITTING 1/4 M -FITTINGS.6 -FITTINGS.6	
07300786	PUMPING REGISTER KNOB	
07300788	STAINLESS STEEL BUSH 7,5x5,1 H5mm	
09100012	GAUGE SCALE 0-4 BAR 1/8 D.40 VA	
09200022	PRESSURE TRANSDUCER 0-4 BAR 3/8	
09200024	PRESSURE TRANSDUCER 0-16 BAR 1/4	
11740001	TEFLON PIPE 6/4	
98031268	PRESSURE SENSOR HOSE	

14.5 STEAM & HOT WATER PARTS

NOTE

** North America Market.

STEAM

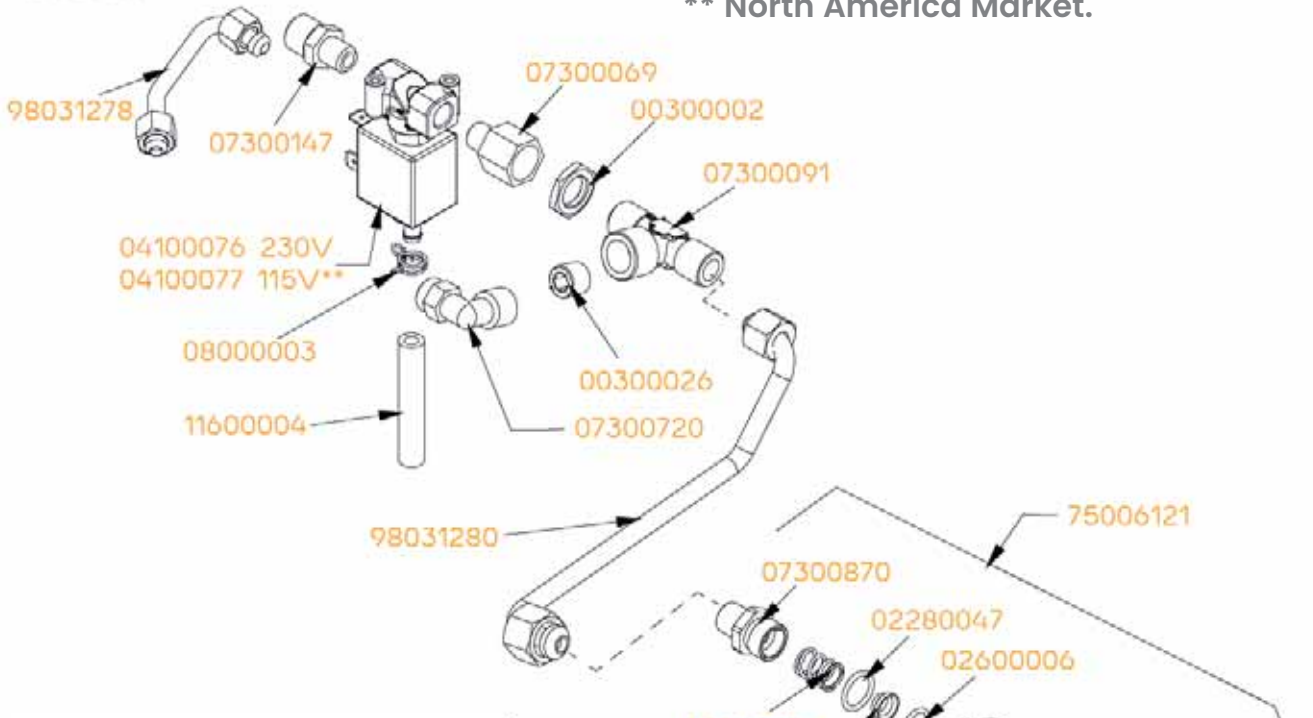

HOT WATER

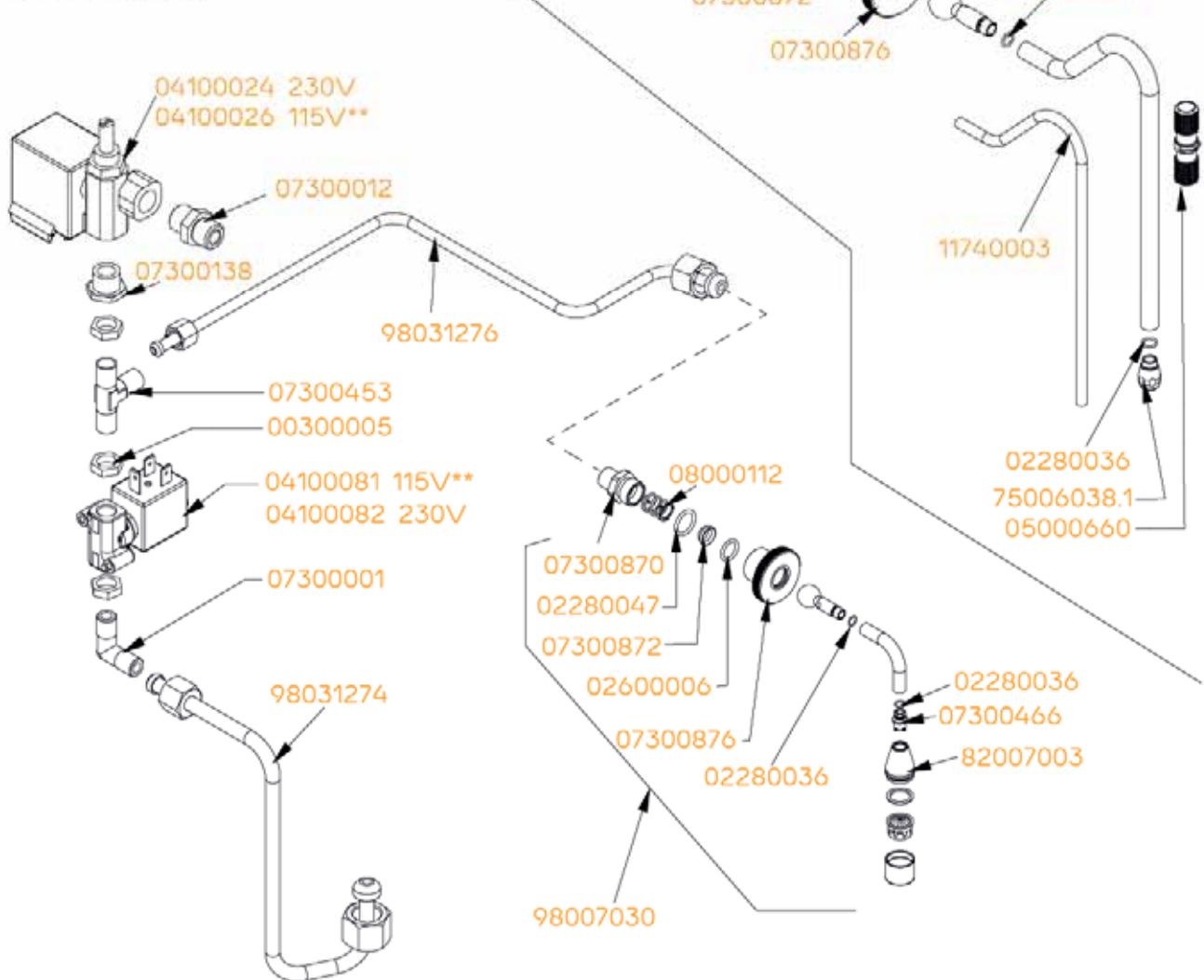

14

CODE	DESCRIPTION	END VALIDITY
00300002	BRASS NUT 1/4 D3 CH18	
00300005	BRASS NUT 1/8 GAS D4 ADD 22.07.96 CH13	
00300026	CONICAL TAP 1/4 GAS	
02280036	O RING STEAM WAND NOZZLE D6x1.2 EPDM70	
02280047	GASKET OR 17,86x2,62 NBR	
02600006	TEFLON GASKET FOR STEAM LANCE BALL	
04100024	3 WAYS SOLENOID 1/4 REGULATOR 90° 230V50/60Hz F3 CE	
04100026	2 WAYS SOLENOID 1/4 REGULATOR 90° 115V 60Hz EPDM F3UL	
04100076	SOLENOID VALVE 3 WAYS 1/8-1/8 220-230V 50/60Hz VITON	
04100077	SOLENOID VALVE 3 WAYS 1/8-1/8 115V 60Hz VITON F2,5 U	
04100081	SOL. VALVE 2 WAYS 1/8-1/8 100/120V 50/60HZ VITON F1.2	
04100082	SOL. VALVE 2 WAYS 1/8-1/8 220-230V 50/60HZ VITON F1.2	
05000660	RUBBER PROTECTION STEAM WAND D10 EAGLE ONE	
07300001	L FITTING 1/8 M-M 459	
07300012	FITTING 1/4 1/4M-1/4M Aisi316	
07300069	1/8" M 1/4" F FITTING ADD. 02.03.88	
07300091	T FITTING MFM 1/4 CYLINDER	
07300138	FITTING ADAPTER 1/4M-1/8F ES.17 OT-58	
07300147	FITTING 1/4 F.7 1/8 F.5 M-M (Update 18.06.97)	
07300453	T FITTING 1/8 M-M-M	
07300466	S/S THREADED CONNECTION FOR STEAM WAND	
07300720	L FITTING 1/4 M - FITTINGS	
07300870	FITTING 3/8 STEAM-WATER ARTICULATED WAND	
07300872	COMPASS JOINT STEAM-WATER WAND	
07300876	STEAM-WATER WAND FIXING RING	
08000003	HOSE CLAMP D9,1	
08000112	SPRING FOR ARTICULATED WAND	
11600004	SILICONE PIPE 5x9 60Sh PEROX	
11740003	CALIBRATED TEFLON PIPE 6/4	
75006038.1	STEAM NOZZLE M8,65X0,75 F1,2 ESAG.1,2	
75006121	COLD STEAM WAND KIT	
82007003	HOT WATER DIFFUSER D23,5 F1/8	
98007030	S/S HOT WATER WAND KIT EAGLE ONE W/ DIFFUSER	
98031274	BOILER PIPE - HOT WATER SOLENOID VALVE	
98031276	HOT WATER WAND PIPE	
98031278	BOILER PIPE - STEAM SOLENOID VALVE	
98031280	STEAM SOLENOID-STEAM WAND PIPE	

14.6 EASYCREAM PARTS

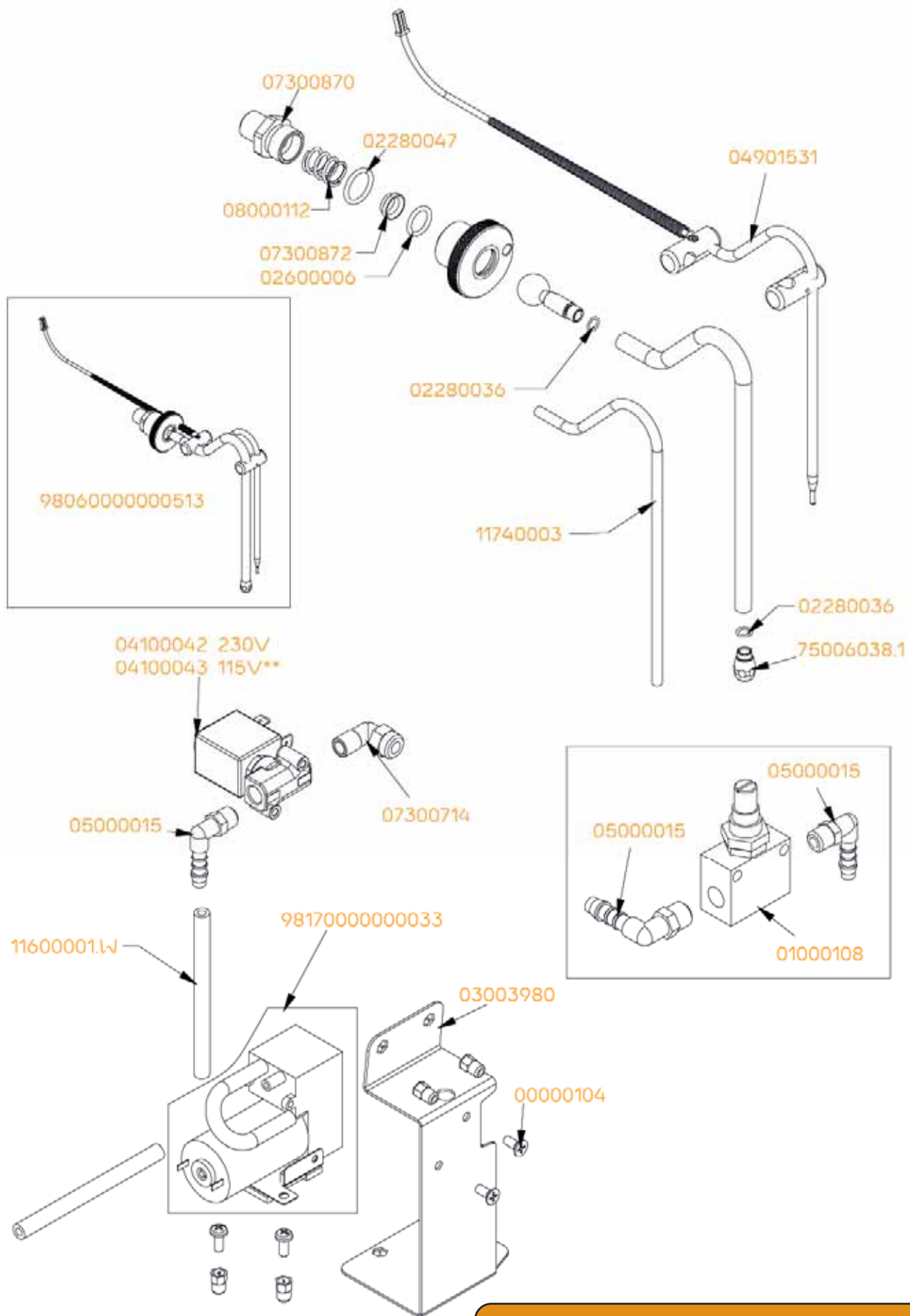

NOTE

** North America Market.



CODE	DESCRIPTION	END VALIDITY
00000104	S/S CROSS HEAD COUNTERSUNK SCREW M4x10 DIN965	
01000108	TAP MRF 1/8 FF 604	
02280036	O RING STEAM WAND NOZZ. D6x1.2 EPDM70	
02280047	GASKET OR 17,86x2,62 NBR	
02600006	TEFLON GASKET FOR STEAM LANCE BALL	
03003980	EASY CREAM COMPONENT SUPPORT	
04100042	2WAY SOLENOID 1/8-1/8 220-230V50/60Hz F2 CE	
04100043	2WAY SOLENOID 1/8-1/8 110-120V 60Hz F2 UL TH1xM4	
04901531	PT1000 PROBE FOR STEAM WAND	
05000015	TUBE FASTENING WES 6R 1/8	
07300714	L FITTING 1/8 M - FITTINGS.6	
07300870	FITTING 3/8 STEAM-WATER ARTICULATED WAND	
07300872	COMPASS JOINT STEAM-WATER WAND	
08000112	SPRING FOR ARTICULATED WAND	
11600001.W	WHITE SILICONE PIPE 4x7,5 60Sh(1mt=4lgr)	
11740003	CALIBRATED TEFLON PIPE 6/4	
75006038.1	STEAM NOZZLE M8,65X0,75 F1,2 ESAG.1,2	
98060000000513	ASSEMBLY JOINT + EASY WAND WITH PROBE	
98170000000033	MICROCOMPRESSOR + SUPPORT SET TALENTO	

14.7 HYDRAULIC GROUP PARTS

NOTE

* Specify version.

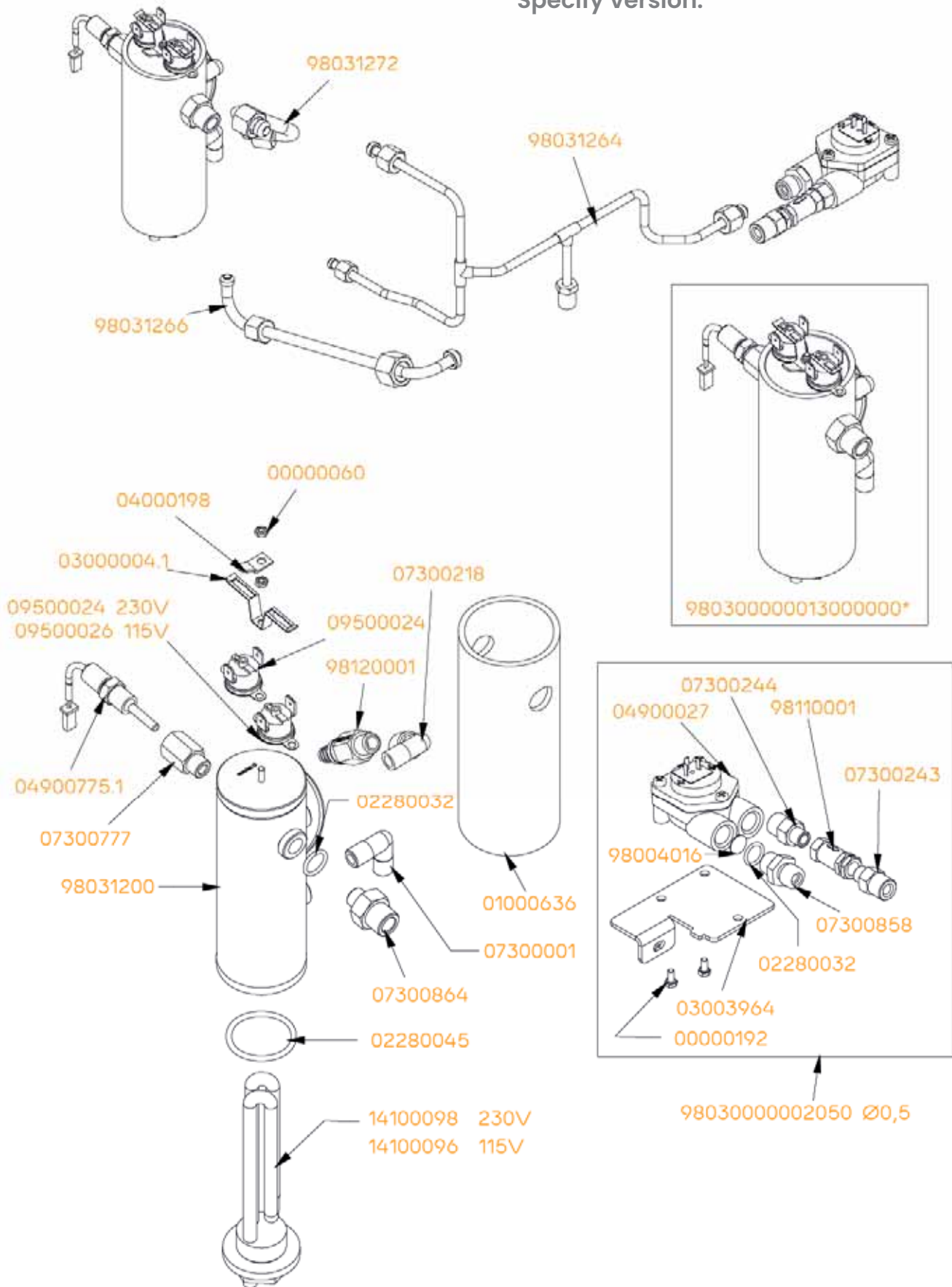

14

CODE	DESCRIPTION	END VALIDITY
00000060	GALVANIC MEDIUM NUT AQ M3	
00000192	S/S SCREW M4x8 TE UNI 5739	
01000636	COFFEE BOILER INSULATION EAGLE ONE	
02280032	GASKET O RING 114 D15 EP 851	
02280045	GASKET O RING 29,82x2,62 EPDM	
03000004.1	DOUBLE BRACKET FOR THERMOSTAT	
03003964	SUPPORT DOSER BRACKET	
04000198	FOIL HOLDER M 6.3 D 4.2 45°	
04900027	BRASS FLOWMETER 1/4-1/4GAS -ATT. HEAD 2,8x0,5	
04900775.1	TEMPERATURE PROBE 150° NTC ATT.1/8 SS 4X20	
07300001	L FITTING 1/8 M-M 459	
07300218	FITTING L 1/8 M-F 458	
07300243	FITTING 1/4M 1/8M GIGLER F.0,5	
07300244	FITTING 1/4M 1/8M + THREADED M8 Aisi303	
07300777	S/S EXTENSION 1/8M 1/8F	
07300858	FITTING 1/4M-1/4M OT-57 USA	
07300864	FITTING 1/4M 1/8M + THREADED M6 Aisi316 +	
09500024	MANUAL THERMOSTAT 135°C TRIP FREE GREEN DRIPPI	
09500026	AUTOMATIC THERMOSTAT 110°C	
14100096	RESISTANCE 3/4 600W 115V	
14100098	HEATING ELEMENT 3/4 600W 230V INCOLOY800	
98004016	S/S FILTER D12	
980300000013000001	COFFEE BOILER ASSEMBLY 1GR. CE	
980300000013000002	COFFEE BOILER ASSEMBLY 1GR. CSA	
98030000002050	FLOWMETER T3 EXTERNAL GIGLER 0,5 SET	
98031200	S/S WELDED COFFEE BOILER D42,5	
98031264	COLD WATER CROSSPIECE	
98031266	DOSER PIPE - COFFEE BOILER	
98031272	COFFEE BOILER PIPE - DISPENSING GROUP	
98110001	RETURN VALVE 1/8 F-FOT-58	
98120001	NEPLAX VITON 16,5 BAR VALVE 1/8 HOSE CLAMP	

14.8 BOILER PARTS

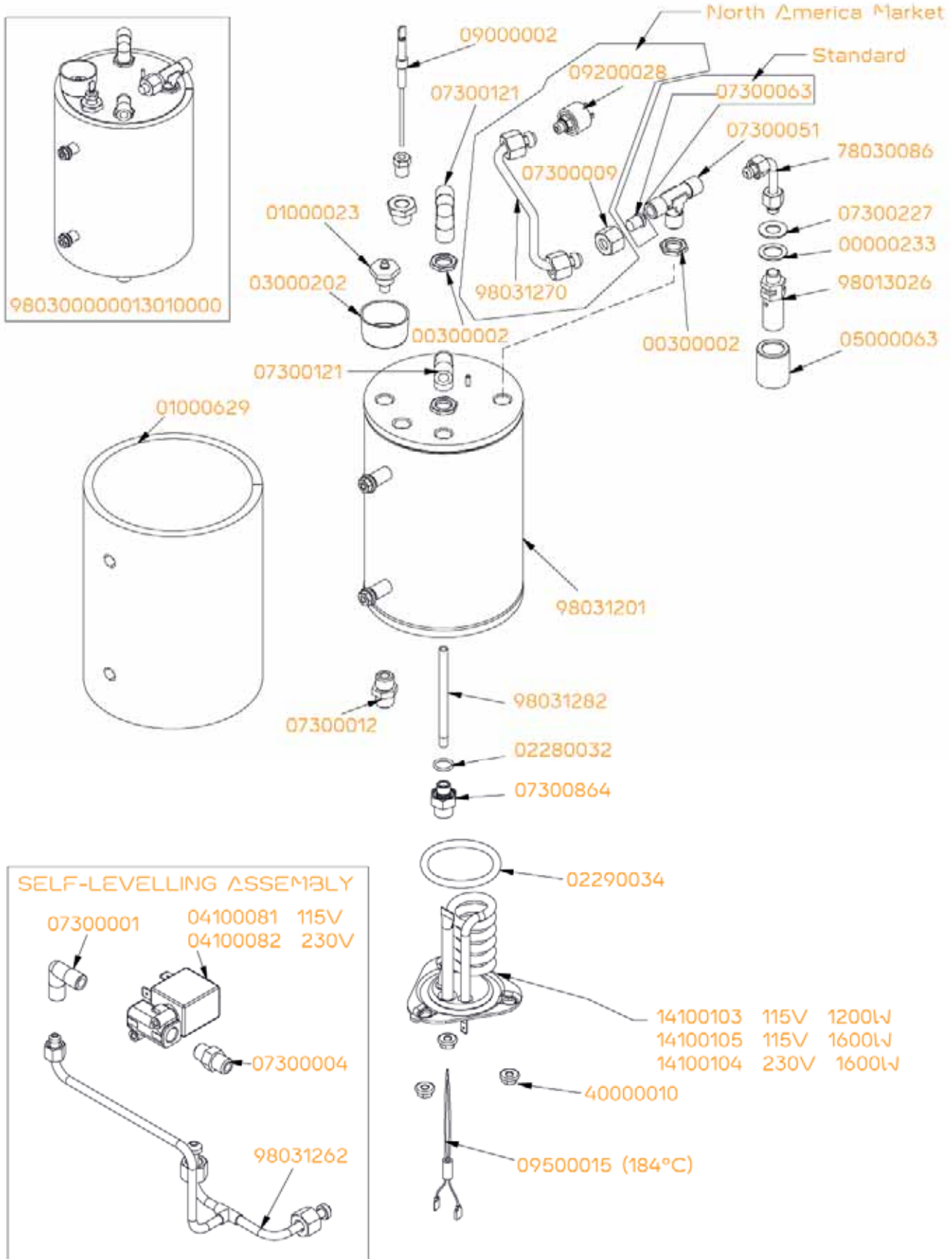

14

CODE	DESCRIPTION	END VALIDITY
00000233	GALVANIC WASHER M16 17x26x1	
00300002	BRASS NUT 1/4 D3 CH18	
01000023	ANTI VACUUM VALVE	
01000629	STEAM BOILER INSULATION	
02280032	GASKET O RING 114 D15 EP 851	
02290034	GASKET O RING 6187 D47x5,34 VITON FDA	
03000202	CONDENSATION TRAY MASTER	
07300012	FITTING 1/4 1/4M-1/4M Aisi316	
04100081	SOL. VALVE 2 WAYS 1/8-1/8 100/120V 50/60HZ VITON FI.2	
04100082	SOL. VALVE 2 WAYS 1/8-1/8 220-230V 50/60HZ VITON FI.2	
05000063	SAFETY VALVE COVER PA6	
07300001	L FITTING 1/8 M-M 459	
07300004	FITTING 1/8-1/8 DIRECT GAS	
07300009	NUT FITTING 1/4 GAS	
07300051	FITTING T 1/4 M-M-M CYLINDER	
07300063	CLOSED TERMINAL D11	
07300121	FITTING L 1/4 M-M CYLINDER (Update 18.02.97)	
07300227	BRASS WASHER D.26X13,5X1,5 ADD.5.06.03	
07300864	FITTING 1/4M 1/8M + THREADED M6 Aisi316 +	
09000002	SELF-LEVEL PROBE COMP. L = 105 WITH THROAT	
09200028	PRESSURE GAUGE 2,7 BAR 16A 230V	
09500015	HEATING ELEMENT THERMAL PROTECTION G5 184°C 16	
14100103	SS FLANGE RESISTANCE 1200W 115V	
14100104	SS FLANGE RESISTANCE 1600W 230V	
14100105	SS FLANGE RESISTANCE 1600W 115V	
40000010	NUT M6 W/ WELDED GALVANIC WASHER	
78030086	LEVEL SOLENOID PIPE PREMIER '01 AURELIA II DGT/T3/CSA	
98013026	SAFETY VALVE D7-S 3 BAR 1/4" VITON 97/23/EC	
980300000013010000	BOILER SET EAGLE ONE 1GR	
98031201	STAINLESS STEEL WELDED BOILER D.114.3	
98031262	SELF-LEVELLING PIPE	
98031270	BOILER PIPE - CSA PRESSURE SWITCH	
98031282	HOT WATER DRAFT HOSE	

14.9 FRAME PARTS

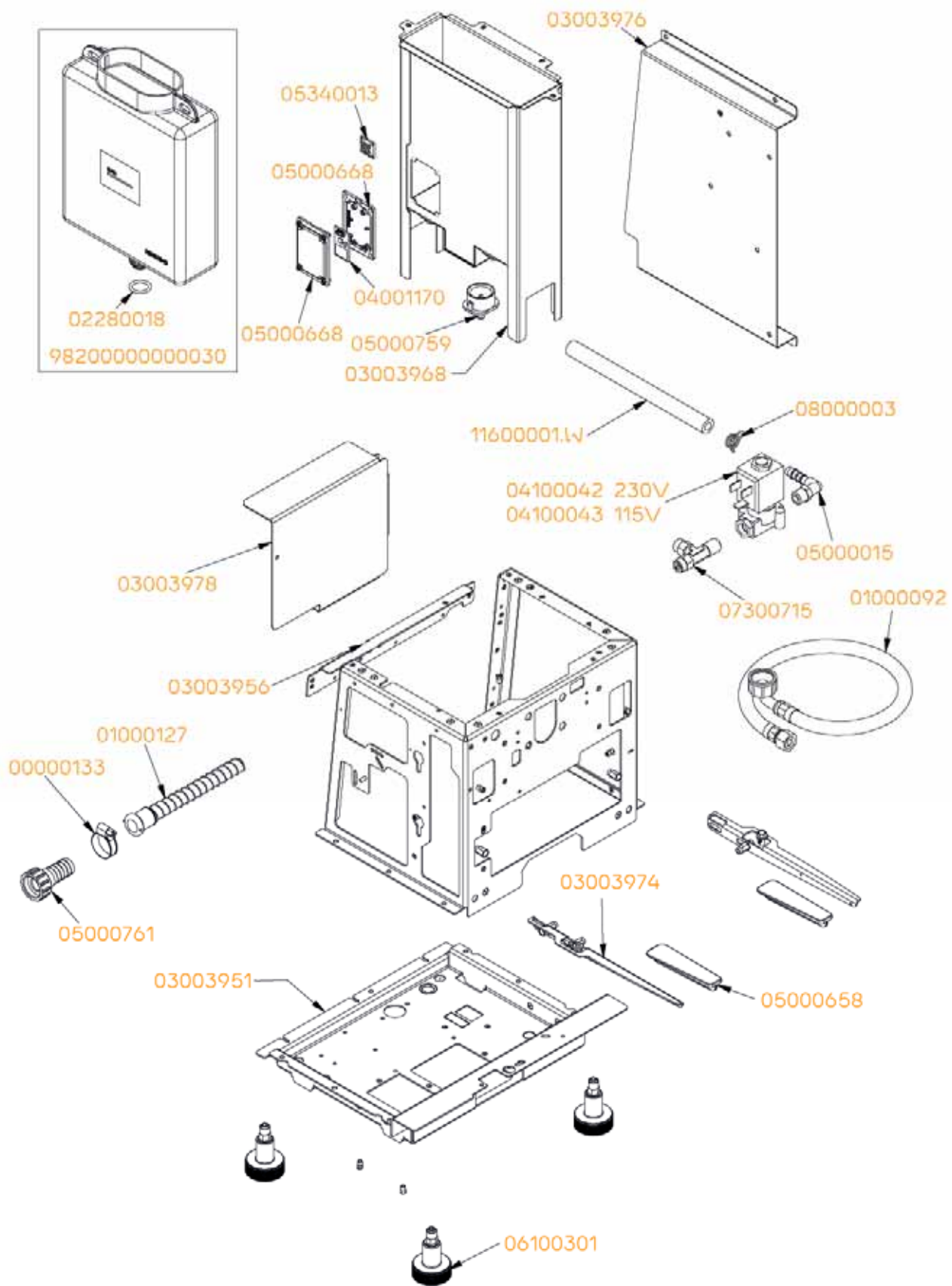

CODE	DESCRIPTION	END VALIDITY
00000133	S/S CLIP WD12 16-25 C7 W2	
01000092	3/8F-3/4F90D WATER CHARGE PIPE 1,5mt + FILTER	
01000127	DIRECT SLEEVE DISCHARGE TUBE D19 L=2m	
02280018	RED SILICON GASKET O RING Sh70	
03003951	FRAME BASE	
03003956	REAR UPPER SHEET	
03003968	WATER TANK SUPPORT	
03003974	LEFT GUIDE SHEET EAGLE ONE IGR	
03003976	CONTROL UNIT SUPPORT	
03003978	ELECTRICAL PARTS SUPPORT	
04001170	PRESENCE TANK SENSOR	
04100042	2WAY SOLENOID 1/8-1/8 220-230V50/60Hz F2 CE	
04100043	2WAY SOLENOID 1/8-1/8 110-120V 60Hz F2 UL TH1xM4	
05000015	TUBE FASTENING WES 6R 1/8	
05000658	FLAT WATER DRIP TRAY EAGLE ONE	
05000668	CAPACITIVE PRESSURE SWITCH SUPPORT	
05000759	WATER TANK COLLECTOR 5LT MICROBAR	
05000761	STRAIGHT FITTING 3/4 Fx19 FOR EXHAUST PIPE	
05340013	SMALL BASE 19X19 FOR BAND WITH SCREW HOLE M4	
06100301	FOOT MACHINE	
07300715	T FITTING 1/8 M -FITTINGS.6 -FITTINGS.6	
08000003	HOSE CLAMP D9,1	
11600001.W	WHITE SILICONE PIPE 4x7,5 60Sh (1mt=4lgr)	
98200000000030	1,5LT WATER TANK SET	

14.10 ELECTRONIC & ELECTRICAL PARTS

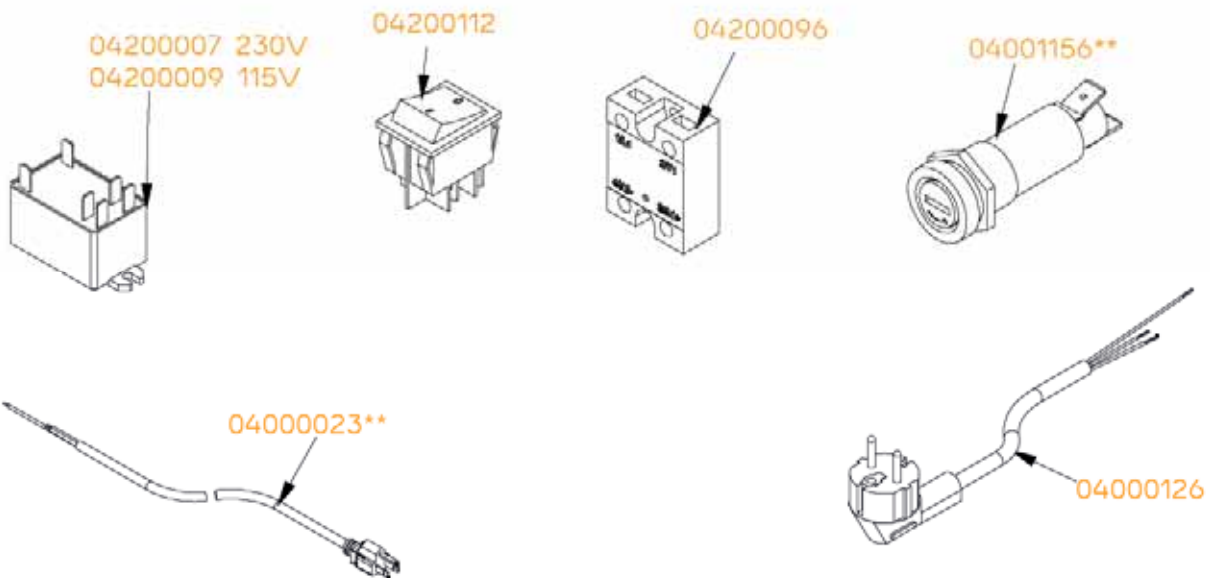
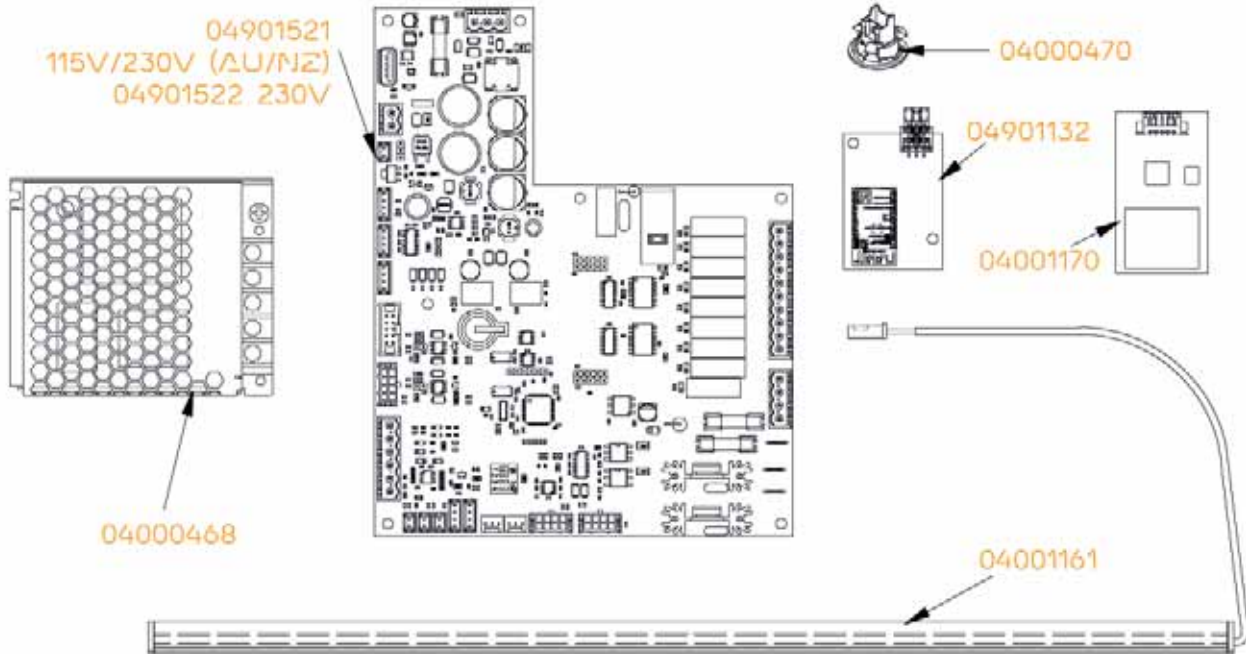

NOTE

** North America Market.



CODE	DESCRIPTION	END VALIDITY
04000023	SUPPLY CABLE UL AWG3X16 USA PLUG SHEATH 90°C 30	
04000126	ELECTRIC CABLE 2MT CE SCHUKO PLUG 90° 3X1,5	
04000244	3POLE CONN CABLE RAST 2.5 / MOLEX L = 800mm	
04000468	TRANSFORMER 24VDC 50W OPTIONAL	
04000470	12VDC LED SPOT AURELIA WAVE	
04001128	WIRING 115 HIGH VOLTAGE	
04001130	WIRING 230 HIGH VOLTAGE	
04001131	WIRING LOW VOLTAGE	
04001144	SUPPLYING WIRING EASY CREAM 1GR.	
04001156	CSA THERMAL DISJUNCER	
04001161	LED STRIP 1GR EAGLE ONE	
04001170	PRESENCE TANK SENSOR	
04001172	CONN. CABLE TANK SENSOR-CONTROL UNIT	
04001174	WI-FI MODULE CABLE-CONTROL UNIT	
04200007	POWER RELAY 30A 230V BIPOLAR	
04200009	POWER RELAY 30A 115V BIPOLAR	
04200096	STATIC RELAY 25A 250V 1OUT	
04200112	RED LIGHT 0/1 BIPOLAR SWITCH UL 16A	
04901132	WI-FI MODULE	
04901521	CONTROL UNIT EAGLE ONE 1GR. USA/CAN - AUS/NZ	
04901522	CONTROL UNIT	





Victoria Arduino

INSPIRED BY YOUR PASSION.

Simonelli Group s.p.a.

Via E. Betti, 1 - 62020

Belforte del Chienti - (MC) Italy

Tel. +39 0733.950243

Fax +39 0733.850247

e-mail: info@victoriaarduino.com

www.victoriaarduino.com